



CORNWALL
FIRE & RESCUE SERVICE
A service of Cornwall Council

Mr A King

Email:
planning@scilly.gov.uk

Your Ref: P/16/111/FUL
My Ref: IOS15175/JG/ES
Date: 07 November 2016

Dear Sir

**PLANNING APPLICATION NO: P/16/111/FUL
KENYTHON, ISLES OF SCILLY**

Further to your letter dated the 20 October 2016 regarding the above planning application, this Authority makes the following observations:

ACCESS FOR FIRE APPLIANCES

The proposed access for fire appliances within the site does not appear to comply with Part B5 of the Building Regulations 2010, 2007 edition Section 16: Vehicle Access.

WATER SUPPLIES

Adequate water supplies for Firefighting purposes will be achieved by:

- Complying with the requirements as detailed in the attached guidance note W102.
- Compliance with Part B5 of the Building Regulations 2010, 2007 edition, Section 15: Fire Mains and Hydrants

Continued...

Cornwall Fire, Rescue and Community Safety Service
St. Austell Community Fire Station, Carlyon Road, St. Austell, Cornwall PL25 4LD

Tel: 0800 3581 999 www.cornwall.gov.uk/fire

Working together to make Cornwall safer



@CornwallFRS



/CornwallFRS



INVESTORS
IN PEOPLE



EXCELLENT
FIRE &
RESCUE
SERVICE
EQUALITY
FRAMEWORK

**SAFER
CORNWALL**
Kernow Salwa



Residential Sprinklers

Cornwall Fire and Rescue Service support the provision of domestic sprinklers into all new residential developments. These should be installed to BS9251 and will reduce the risk to life and significantly reduce the degree of damage caused by fire. This consideration if implemented will enhance the safety of the occupants and any attending firefighters whilst providing property protection and maintaining the buildings continuity.

Should you require any further assistance please do not hesitate to contact this Department.

Yours faithfully

A handwritten signature in black ink, appearing to read 'J Garcia', with a stylized flourish at the end.

Joe Garcia
Watch Manager – Fire Protection
Cornwall Fire & Rescue Service
Tel: 01726 72582
Email: csadmin@fire.cornwall.gov.uk
PL1E

Enc: W102

Cornwall Fire & Rescue Service

Water Supplies for Firefighting & Access for Fire Appliances

1.0 ACCESS FOR FIRE APPLIANCES

Pedestrian Priority

Pedestrian schemes must take into account the need for permanent and unobstructed access for firefighting appliances. The siting of ornamental structures such as flower beds, must take account, not only of the access requirements of fire appliances, but the need to be able to site them in strategic positions; in particular, account must be taken of the working space requirements of aerial appliances. Consultation must take place with the Fire Authority during the earliest planning stages of any development to ensure adequate access for fire appliances, their siting and use.

Access and Facilities for the Fire Service

If the application involves the construction of a building you will be required to provide reasonable facilities for the Fire Service. In most circumstances this will mean providing vehicular access for fire appliances.

It is important to remember that failure to do so may prevent the applicant from obtaining a completion certificate under the Building Regulations but more importantly, the lives of the occupiers will be put at risk.

| Appliance type | Pump | High Reach |
|--|-------------|-------------------|
| Minimum width of road between kerbs(m) | 3.7 | 3.7 |
| Minimum width of gateways(m) | 3.1 | 3.1 |
| Minimum turning circle between kerbs (m) | 16.8 | 26.0 |
| Minimum turning circle between walls (m) | 19.2 | 29.0 |
| Minimum clearance height(m) | 3.7 | 4.0 |

| | | |
|------------------------------------|------|------|
| Minimum carrying capacity (tonnes) | 12.5 | 17.0 |
|------------------------------------|------|------|

Design of access routes and hard standings

A vehicle access route may be a road or other route which, including any manhole covers and the like, meets the standards in Tables 1 and 2 (page 3).

Where access is provided to an elevation for high reach appliances in accordance with Table 1, overhead obstructions such as cables and branches that would interfere with the use of ladders etc. should be avoided.

Domestic Dwelling Houses

There should be vehicle access for a pumping appliance to within 45m of all points within the dwelling house. Every elevation to which vehicle access is provided should have a suitable door, not less than 750mm wide, giving access to the interior of the building.

Flats or Maisonettes

There should be vehicle access for a pumping appliance to blocks of flats or maisonettes to within 45m of all points within each dwelling.

Other Buildings

The access requirements for other buildings will depend upon the total floor area and the height. Further detailed guidance can be found in Table 19 of the Building Regulations Approved Document B Volume 2 (2006 edition (amended 2007)) B5.

2. HYDRANT INSTALLATIONS

Underground fire hydrants, surface box frames, covers, and indicator plates must comply with the specifications set out in British Standards BS750: 2012 and BS3251: 1976 (*see Fig 2 overleaf*) respectively and be installed in accordance with BS5306: Part 1: 1976 (1983) (*see Fig 1 overleaf*).

Additional requirements are:

- 2.1 *Hydrants should be sited in pavements wherever possible.*
- 2.2 *The screwed outlet of the hydrant shall be made of METAL in accordance with the laid down British Standards.*

2.3 *Indicator plates shall be fixed in accordance with Appendix 'A' of BS3251: 1976 to a purpose made concrete post which should be conspicuously sited facing and as close to the hydrant as practicable. These indicator posts shall have an all over durable finish conforming to colour reference no.309 (canary yellow) in BS381C. In exceptional circumstances where it is not possible to site an indicator post, then the indicator plate should be fixed in accordance with Appendix 'A' of BS3251: 1976 to a nearby wall at a height of not more than 1.2 metres or less than 0.6 metres from ground level.*

3. MAIN SIZES: FLOWS: SPACING

Housing

Minimum of 8 l/sec (480 l/min) for detached or semidetached of not more than two floors up to 35 l/sec (2100 l/min) for units of more than two floors, from any single hydrant on the development.

Transportation

Minimum of 25 l/sec (1500 l/min) for lorry/coach parks, multi-storey car parks and service stations from any hydrant on the development or within a vehicular distance of 90 metres from the complex.

Industry (industrial estates)

It is recommended that the water supply infrastructure should provide as follows with the mains network on site normally being at least 150mm nominal diameter:

Up to one hectare minimum of 20 l/sec (1200 l/min)

One to two hectares minimum of 35 l/sec (2100 l/min)

Two to three hectares minimum of 50 l/sec (3000 l/min)

Over three hectares minimum of 75 l/sec (4500 l/min)

Note: High risk areas may require greater flow rates.

Shopping, offices, recreation and tourism

Minimum of 20 l/sec (1200 l/min) to 75 l/sec (4500 l/min) depending on the nature and extent of the development.

Education, health and community facilities

a. Village halls

Minimum of 15 l/sec (900 l/min) through any single hydrant on the development or within a vehicular distance of 100 metres from the complex.

b. Primary schools and single storey health centres

Minimum of 20 l/sec (1200l/min) through any single hydrant on the development or within a vehicular distance of 70 metres of the complex.

c. Secondary schools, colleges, large health centres and community facilities

Minimum of 35 l/sec (2100 l/min) through any single hydrant on the development or within a vehicular distance of 70 metres from the complex.

Caravan sites - caravans/chalets

A fire hydrant should be located at the entrance to the site and if necessary, at 300 metre intervals. The hydrant should provide a minimum of 8 l/sec (480 l/min). If no piped water supply is available or where there is insufficient pressure or flow in the water main an alternative source must be provided. Suitable alternative sources are indicated on the following pages.

4.0 CONSULTATION

These observations are offered for guidance. It is important that the Chief Fire Officer should be consulted at the design stage in respect of each scheme, especially with regard to the position of any private hydrants within the site area. The Water Company must also be consulted.

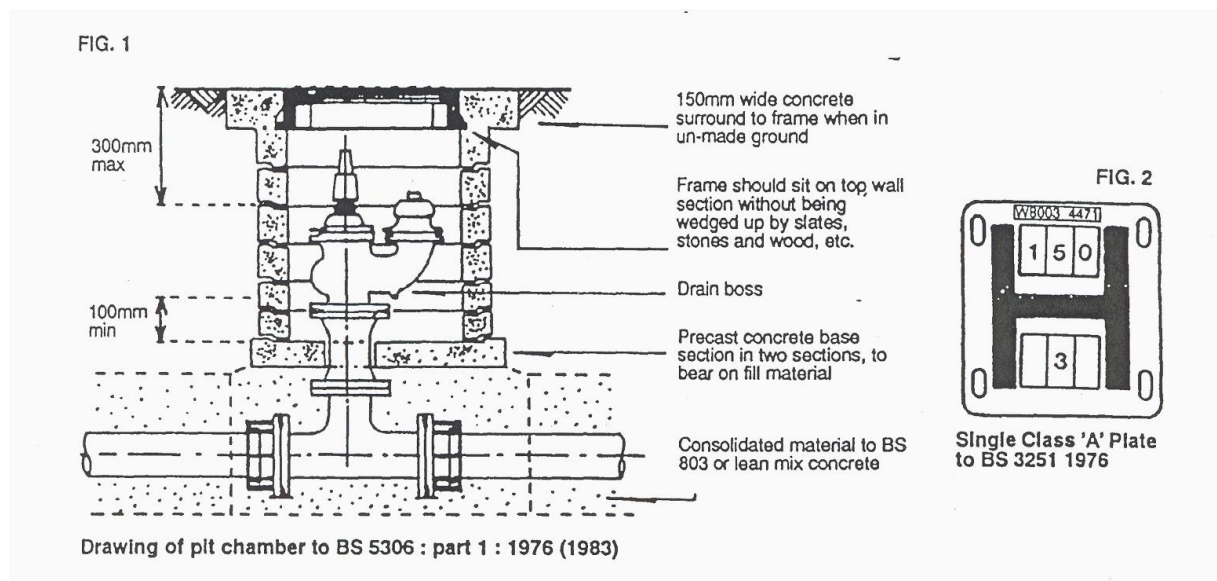

Developers should hold joint discussions with South West Water or the Environment Agency and the Fire Authority to ensure that adequate water supplies are available in case of fire.

The Fire Authority reserve the right to ask for static water supplies for firefighting on site as a condition of planning consent, if the supply infrastructure is inadequate for any given risk.