

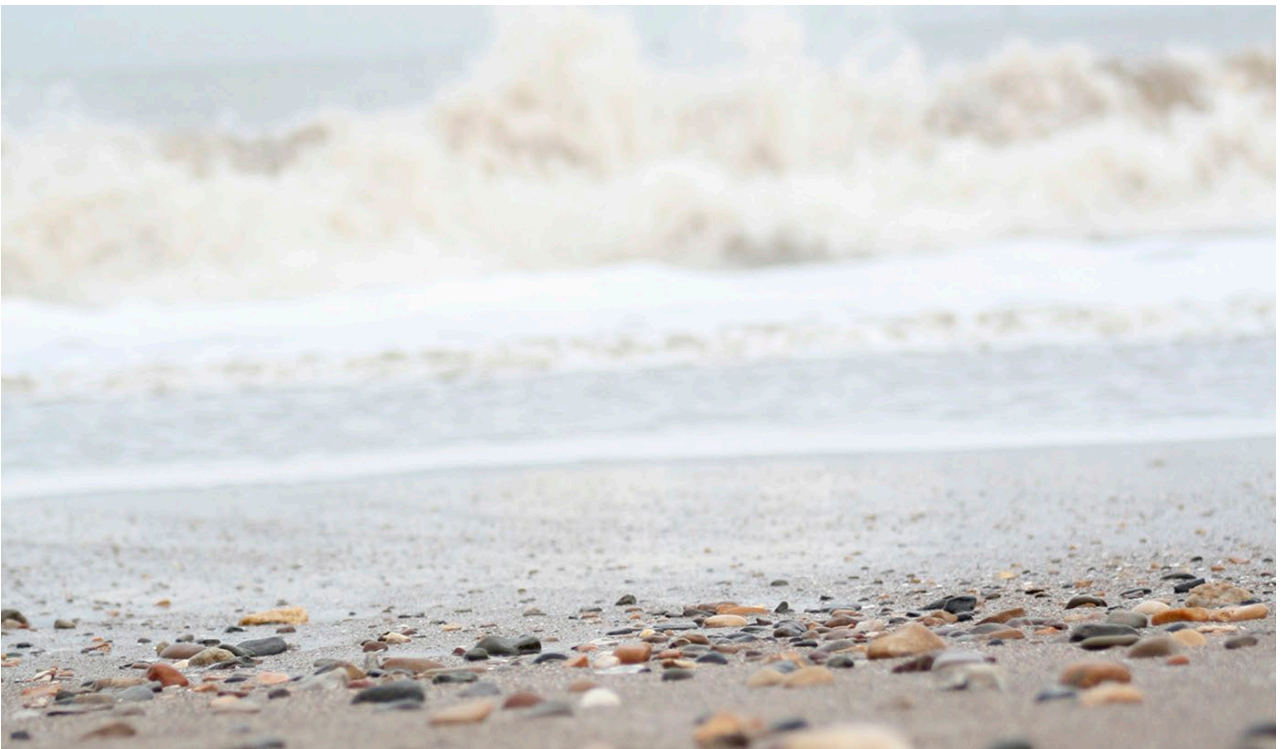

HR Wallingford
Working with water

Isles of Scilly - Design Services for Off Islands Coastal Erosion Defence and Dune Management

Climate Adaption Scheme - Detailed Design Report -
Bryher



DKR6499-RT006-R02-00

30 August 2022

Document information

Document permissions	Confidential - client
Project number	DKR6499
Project name	Isles of Scilly - Design Services for Off Islands Coastal Erosion Defence and Dune Management
Report title	Climate Adaption Scheme - Detailed Design Report - Bryher
Report number	RT006
Release number	02-00
Report date	30 August 2022
Client	Council of the Isles of Scilly
Client representative	Stephen Swabey
Project manager	Aurora Orsini
Project director	Dr Tim Pullen

Document history

Date	Release	Prepared	Approved	Authorised	Notes
30 Aug 2022	02-00	AGC	AUO	AUO	
15 Jul 2022	01-00	AGC	AUO	TAP	

Document authorisation

Prepared	Approved	Authorised
Andy Campbell	Aurora Orsini	Aurora Orsini

© HR Wallingford Ltd

This report has been prepared for HR Wallingford's client and not for any other person. Only our client should rely upon the contents of this report and any methods or results which are contained within it and then only for the purposes for which the report was originally prepared. We accept no liability for any loss or damage suffered by any person who has relied on the contents of this report, other than our client.

This report may contain material or information obtained from other people. We accept no liability for any loss or damage suffered by any person, including our client, as a result of any error or inaccuracy in third party material or information which is included within this report.

To the extent that this report contains information or material which is the output of general research it should not be relied upon by any person, including our client, for a specific purpose. If you are not HR Wallingford's client and you wish to use the information or material in this report for a specific purpose, you should contact us for advice.

Contents

1	Introduction.....	7
2	Report Structure	8
3	Input Data	9
3.1	Reference documents	9
3.2	Data assumptions.....	10
3.3	Site design data.....	10
3.4	HOLDS	11
3.5	Drawing list.....	11
4	Design Basis	12
4.1	General.....	12
4.2	Codes and Standards.....	13
4.3	Design assumptions	14
4.3.1	Waves	14
4.3.2	Ground conditions.....	15
5	Design	16
5.1	Site 1 – Great Porth (south of Great Carn) - DKR6499/210/D110; DKR6499/210/D310	16
5.1.1	Overtopping assessment.....	16
5.1.2	Hydraulic stability	17
5.1.3	Filter layer & geotextile	19
5.1.4	Geomat	19
5.1.5	Design section and tie in to existing ground	20
5.2	Site 2/3b – Great Porth (north of Great Carn) (DKR6499/210/D111;DKR6499/210/D320; DKR6499/210/D321; DKR6499/210/D322; DKR6499/210/D323; DKR6499/210/D324).....	20
5.2.1	Overtopping assessment.....	21
5.2.2	Hydraulic stability	22
5.2.3	Flood gate	22
5.2.4	Great Pool outfall	24
5.2.5	Design section and tie in to existing ground	24
5.3	Site 3 – Stinking Porth (DKR6499/210/D112; DKR6499/210/D330).....	25
5.3.1	Overtopping assessment.....	25
5.3.2	Hydraulic stability	26
5.3.3	Filter layer & geotextile	26
5.3.4	Design section and tie into existing ground	27
5.4	Site 4 – Great Popplestone (DKR6499/210/D113; DKR6499/210/D340).....	27
5.4.1	Overtopping assessment.....	28
5.4.2	Hydraulic stability	28
5.4.3	Design section and tie into existing ground	29
5.5	Site 5 – Kitchen Porth (DKR6499/210/D114; DKR6499/210/D350)	30
5.5.1	Overtopping assessment.....	31
5.5.2	The hydraulic stability	31
5.5.3	Design section	31
5.6	Site 8 – The Quay – (DKR6499/210/D115; DKR6499/210/D360)	32

5.6.1	Hydraulic stability	32
5.6.2	Geotextile	33
5.6.3	Design section	33
5.7	Site 9 – Green Bay – (DKR6499-210-D116; DKR6499-210-D370).....	34
5.7.1	Overtopping assessment	34
5.7.2	Geobag stability	35
5.7.3	Design section	35
6	Materials	36
7	Ground Investigation	36
8	Health and Safety	36
9	Bills of Quantity & cost estimates	37
9.1	Indirect costs	37
9.1.1	Management and supervision.....	38
9.1.2	Contractors preliminaries (Mob/Demob).....	38
9.1.3	Contingency	38
9.2	Direct costs	38
9.3	Island summaries	39
10	Environment and Constructability	39
10.1	General logistics	39
10.2	Plant & labour	40
10.3	Materials	41
10.4	Environment	41
11	References	41

Appendices

A Design Bases

- A.1 Design life
- A.2 Coordinate system
- A.3 Vertical datum
- A.4 Data
 - A.4.1 Topographic and Bathymetric data
- A.5 Water Levels
 - A.5.1 Sea and tidal levels
 - A.5.2 Extreme water levels
 - A.5.3 Sea level rise
- A.6 Waves
 - A.6.1 Extreme wave heights and water levels
- A.7 Overtopping assessment
- A.8 Materials
 - A.8.1 Quarry rock properties
 - A.8.2 Concrete properties
 - A.8.3 Dune/Ridge recharge material
 - A.8.4 Geotextile properties
- A.9 Design criteria
 - A.9.1 Ultimate limit states

A.9.2 Serviceability limit states

A.10 Code and standards

B Calculations

C Drawings

D CDM (2015)

E Utility Plans

F Bills of Quantity

G Product Information

G.1 Geotextile

G.2 Geobags

G.3 Geomattting

G.4 Flood gate

Tables

Table 3.1: Input data and reference documents	9
Table 3.2: Bryher detailed design drawings	11
Table 4.1: Design waves and water levels	12
Table 5.1: Site 1 – Great Porth (south of Great Carn) crest height design	17
Table 5.2: Rock armour design parameters for Great Porth South	17
Table 5.3: Size distribution for 1-3t (standard grading)	19
Table 5.4: Site 2/3b – Great Porth (north of Great Carn) crest height design	21
Table 5.5: Rock armour design parameters for Great Porth North	22
Table 5.6: Site 3 – Stinking Porth crest height design	26
Table 5.7: Rock armour design parameters for Stinking Porth	26
Table 5.8: Site 4 – Stinking Porth crest height design	28
Table 5.9: Rock armour design parameters for Great Popplestone	28
Table 5.10: Rock armour design parameters for Kitchen Porth	31
Table 5.11: Rock armour design parameters for the Quay	33
Table 5.12: Site 9 – Green Bay crest height design	35
Table 9.1: Bryher cost summary	39

Figures

Figure 1.1: Location of sites in Bryher (Numbers refers to the provided wave points from JBA)	8
Figure 4.1: Location of wave extraction points	13
Figure 5.1: Definition of condition grade in the EA's Condition Assessment Manual	16
Figure 5.2: Site 1 – Great Porth (south of Great Carn) typical section	20
Figure 5.3: Great Par South flood gate arrangement	23
Figure 5.4: Site 2/3b – Section through Great Pool outfall	24
Figure 5.5: Site 2/3b – Great Porth (north of Great Carn) typical section	25
Figure 5.6: Site 3 – Stinking Porth typical section	27
Figure 5.7: Site 4 – Great Popplestones typical sections	30
Figure 5.8: Site 5 – Kitchen Porth typical section	32
Figure 5.9: Site8b – The Quay groyne section and elevation	34
Figure 5.10: Site 9 – Green Bay typical profile detail	35
Figure 8.1: Bryher chart	37

Figure 10.1: Bryher site boundaries, access routes and access hazards.....40

1 Introduction

The Isles of Scilly have received funding from the European Regional Development Fund and the Environment Agency to complete a range of climate change adaptation works in the Scilly Isles of St Agnes, Bryher and St Martins. These include interventions, such as coastal protection works, renourishment of existing beaches and dunes, upgrade or/and construction of new defences, aiming to reduce the impact of coastal erosion and wave overtopping exacerbated by future climate change scenarios.

The Isles of Scilly are one of the areas in Europe most vulnerable to the effects of climate change, sea level rise and consequent increased risk of inundation, overtopping and coastal erosion.

The council of the Isles of Scilly (referred in this report also as “the Client”) has commissioned HR Wallingford to undertake this work to evaluate the risk at the sites identified as being most vulnerable and develop designs for the coastal works proposed.

HR Wallingford has developed the preliminary design of the coastal works, which included identification and appraisal of the proposed alternative options for the sites identified for intervention, from the OBC (2020), the selection of the preferred option and the development of the designs for planning application.

The present report presents the development to detailed design stage of the preferred options for the coastal sites located on the Island of Brhyer, the westernmost inhabited of the isles of Scilly.

The sites are located around the island with sites on the east and west of the Island as shown in Figure 1.1.

- Site 1 - Great Porth/Par south of Great Carn
- Site 2/3b - Great Porth (Great Par) north of Great Carn
- Site 3 - Stinking Porth
- Site 4a - Great Popplestone
- Site 5 - Kitchen Porth
- Site 8b - The Quay
- Site 9 - Green Bay.

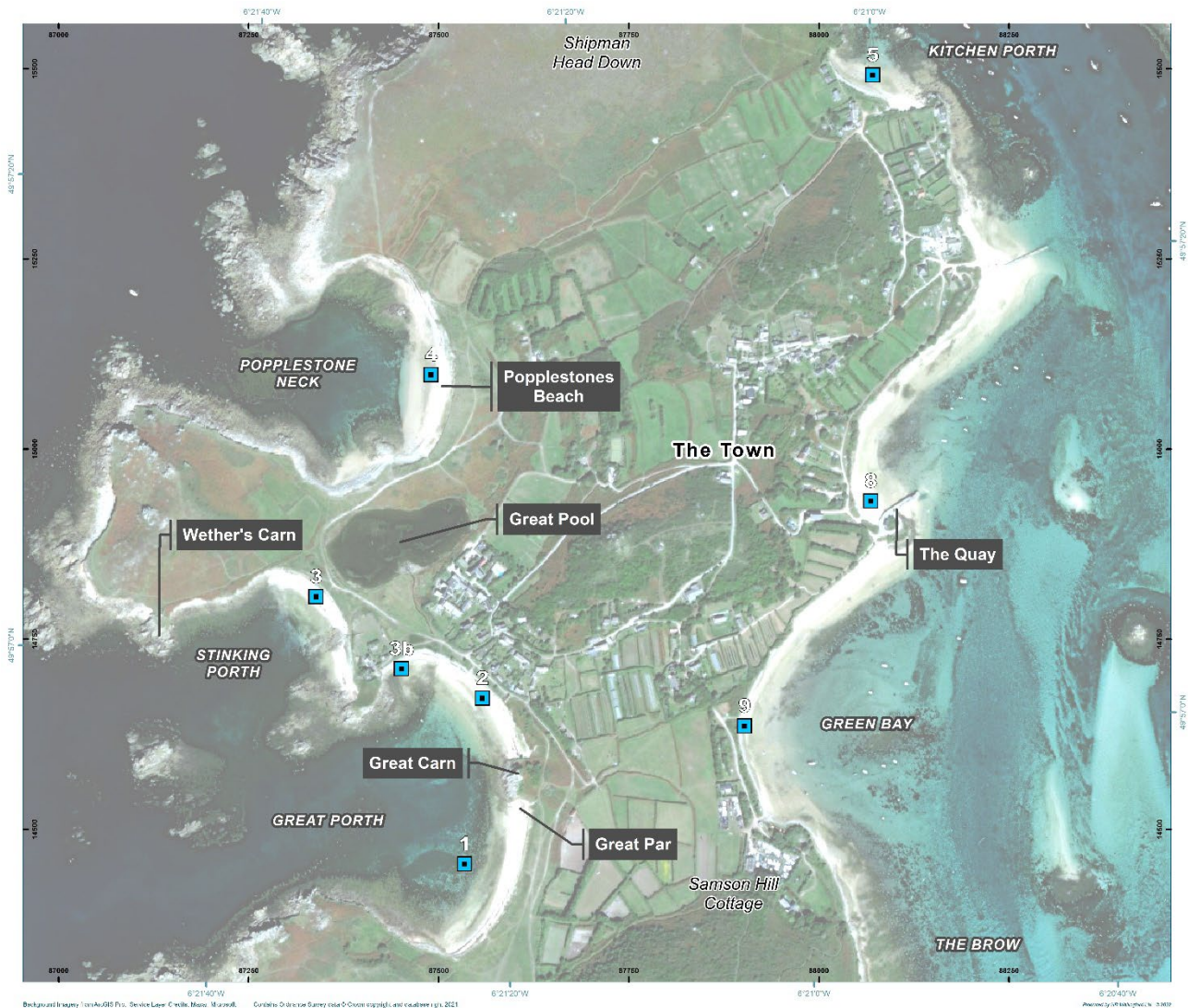

Figure 1.1: Location of sites in Bryher (Numbers refers to the provided wave points from JBA)

2 Report Structure

This document is the RIBA Stage 4 detailed design report for the proposed climate adaptation coastal protection works on the island of Bryher. The design reports for the other two islands, St. Agnes and St Martin's are included in separate documents DKR6499-RT005 and DKR6499-RT007, respectively.

The structure of the present report is the following:

- Section 3 presents the received data used for the design and design basis for the scheme and drawing list
- Section 4 presents the overtopping assessments at each site used to set the crest heights
- Section 5 presents the design for each of the sites
- Section 6 presents the ground condition assumptions and proposed works
- Section 7 presents the health, safety and welfare assessment for the design
- Section 8 presents the BoQ and cost estimates for the proposals
- Section 9 includes a summary of the constructability of the proposed designs.

The following information are presented in the Appendices:

- Appendix A – Design basis
- Appendix B – Sample design calculations
- Appendix C – Drawings
- Appendix D – CDM (2015) risk assessment
- Appendix E – Bills of Quantity
- Appendix F – Cost estimate
- Appendix G – Product information.

3 Input Data

3.1 Reference documents

The designs and layouts for the Island of Bryher have been developed and presented through a series of HR Wallingford reports, initially during the inception stage studies following a site visit and subsequently during the preliminary design stage (RIBA Stage 3). Relevant HR Wallingford reports are listed below. In addition below are also listed all the relevant references and data provided to HR Wallingford and used in the development of the detailed design.

Table 3.1: Input data and reference documents

Reference Number	Document Title	Published	Provided by
1.	Scope of Work- RFP- Annex B_Brief for Off-Island Coastal Defence Works_Final	2021	Council of the Isles of Scilly
2.	Adaptive Scillies – Natural Dune Restoration & Flood Resilience – FCERM Outline Business Case	JBA, Arcadis, Council of the Isles of Scilly, April 2020	Council of the Isles of Scilly
3.	Isles of Scilly – Coastal Flood Modelling – Final Main Report	JBA, Environment Agency, February 2019(a)	Council of the Isles of Scilly
4.	Isles of Scilly – Coastal Flood Modelling- Model development Report	JBA, Environment Agency, February 2019(b)	Council of the Isles of Scilly
5.	DKR6499_RT01-Site Visit Notes	HR Wallingford 2021	HR Wallingford
6.	SMP2	2010	Council of the Isles of Scilly
7.	SMP2 interim review	2016	Council of the Isles of Scilly
8.	DKR6499-RT003-R02-00 Bryher Preliminary Design report	HR Wallingford 2021	HR Wallingford
9.	LiDAR point cloud data	2007, 2014, 2020	National LiDAR Programme
10.	JBA wave datasets	JBA, Environment Agency, February 2019	Council of the Isles of Scilly
11.	JBA outputs (JBA_Overtopping_Schemitisation_QA_Sheet_2016s4861 Bryher 1 to 11_v2, (JBA_Overtopping_Schemitisation_QA_Sheet_2016s4861 St Agnes 48 to 51_v2, (JBA_Overtopping_Schemitisation_QA_Sheet_2016s4861 St Martins 26 to 29)	JBA, Environment Agency, February 2016	Council of the Isles of Scilly

Reference Number	Document Title	Published	Provided by
12.	Isles of Scilly 2021 Environmental Agency asset inspection	2021 (DRAFT)	Plymouth Coastal Observatory
13.	Drawing B2908/03 – Great Popplestones plan and cross sections (DHV)	04/1994	Council of the Isles of Scilly
14.	Drawing B2989-04 – Great Porth (Plan and Cross Sections (DHV)	04/1994	Council of the Isles of Scilly

3.2 Data assumptions

The main assumptions made during the design studies are summarised below;

- As built drawing of the wall at Popplestones beach were not available, though design drawings from 1994 were provided. No condition survey was available, though the visual inspection from site visit and the September 2021 inspection of the defence assets, undertaken by the Plymouth Coastal Observatory (PCO) considered the wall as in “Fair” condition (see Section 5.4). Therefore, it was assumed that no remediation is required to the structure.
- The visual inspection from site visit and the September 2021 inspection of the defence assets, undertaken by the Plymouth Coastal Observatory (PCO) considered the quay at Ferry Quay as in Good condition and therefore the placement of rock adjacent to the structure does not affect or clash with the quay foundations.
- The slipway at Great Porth is not considered as an asset by the Environment Agency and was not included in the PCO survey. The visual inspection indicated that the slipway was a sound concrete structure and any local works for installation of flood gates and supports and placement of rock will not affect the integrity of the concrete.
- LiDAR data is a true representation of absolute ground levels to Ordnance Datum, though at some locations, where vegetation extends above ground, it is possible that the crest of the vegetation is picked as the ground elevation. Therefore a topographic survey should be carried out prior to construction. This is also stated in the drawings.
- Where identified in drawings, local cobbles and rock can be sourced in sufficient quantities to supplement the armourstone required for the works.
- Excavated embankment/ridge material is uncontaminated and suitable for reuse without any remediation.
- The visual inspection from site visit and the September 2021 inspection of the defence assets, undertaken by the Plymouth Coastal Observatory (PCO) considered the outfall at Great Porth and concrete surround as in Poor condition however the Client has instructed that and works to the outfall are not included in this contract and it can be assumed no remediation is required and therefore rock can be placed directly on top.

3.3 Site design data

Site design data have been provided by others and are listed in Table 3.1 above. Key data used for design are summarised below. No new further field or other data were collected for these design works.

- Design waves (Ref 10) – Data sets for each site were provided with Hs, Tp and water level ranked in order of severity of overtopping event. These have been taken as the waves at the toe of the JBA assumed structures as stated in their assumptions. The elevations for the toes have been extracted from the JBA spreadsheets provided (Ref 11) at the start of the project by the Client.

- LiDAR (Ref. 9) – 2007, 2014, 2018 and 2020 data sets were compared to check correlation. There was good correlation between the data sets at the sample locations checked and the 2020 data set has been taken as the baseline level for this design.

Where localised anomalies in the crest elevation (picks) were noticed due to the presence of vegetation picked up by LiDAR as ground elevation, the levels have been adjusted and adjustments stated in the drawings and/or in this Engineering Report.

It is noted that there was a Ordnance Datum shift in 2015, but the LiDAR data for Bryher showed good correlation between the data sets at the locations checked, and so it is assumed that the earlier data had been corrected.

3.4 HOLDS

Several HOLD items were included in the Preliminary Design report (Ref 8) and several of these remain as HOLD items to be confirmed prior to start of construction.

- Detailed topographic survey, including ground truthing of LiDAR data. This is needed to confirm extent of works and quantities required. Due to this, typical sections rather than full package of detailed section drawings have been produced as the levels, and hence final extent of the proposed works, are to be confirmed.
- Ground investigation information.

As-built drawings for Popplestones wall and the slipway at Great Porth are not expected to be available, but it is assumed that the structures and foundations can accommodate the proposed works. Design drawings for Popplestone and the Great Porth outfall has been provided to inform the design but these are not as-built drawings and the details are different to what is present on site.

3.5 Drawing list

This report should be read in parallel with the drawings listed in Table 3.2 below, which illustrate the detailed engineering design of the coastal works at the identified locations around the island.

Given that no topographic survey, other than LiDAR, is available, the cross sections provided are typical sections, at specific locations.

Drawings are provided in Appendix C.

Table 3.2: Bryher detailed design drawings

Drawing number	Title
DKR6499/000/D101	Project Location Map
DKR6499/000/D102	General Notes
DKR6499/000/D104	Bryher LIDAR Survey Layout
DKR6499/210/D110	General Arrangement Bryher - Great Porth/Par South - 1
DKR6499/210/D111	General Arrangement Bryher - Great Porth North, North of Great Carn - 2&3B
DKR6499/210/D112	General Arrangement Bryher - Stinking Porth - 3
DKR6499/210/D113	General Arrangement Bryher - Great Popplestone - 4
DKR6499/210/D114	General Arrangement Bryher - Kitchen Porth - 5
DKR6499/210/D115	General Arrangement Bryher - Quay - 8B
DKR6499/210/D116	General Arrangement Bryher - North Green Bay - 9
DKR6499/210/D310	Bryher 1 - Great Porth/Par South - Typical Section

Drawing number	Title
DKR6499/210/D320	Bryher 2&3B - Great Porth North, North of Great Carn - Typical Sections
DKR6499/210/D321	Bryher 2&3B - Great Porth North, North of Great Carn – Flood Gate General Arrangement
DKR6499/210/D322	Bryher 2&3B - Great Porth North, North of Great Carn – Flood Gate Details
DKR6499/210/D330	Bryher 3 - Stinking Porth - Typical Section
DKR6499/210/D340	Bryher 4 - Great Popplestone - Typical Sections
DKR6499/210/D350	Bryher 5 - Kitchen Porth - Typical Section
DKR6499/210/D360	Bryher 8B - Quay - Typical Sections
DKR6499/210/D370	Bryher 9 - North Green Bay – Details and Typical Sections

4 Design Basis

4.1 General

The design bases for the works are presented in the Preliminary Design Report, DKR6499-RT002, and have been reproduced here in Appendix A. The waves used for the design of each site have been assessed based on data provided by JBA (Ref. 4) and are included as Table 4.1.

Design waves and combined extreme water levels for the 45 year return period have been estimated, following the methodology outlined in the Preliminary design report (Ref 8). These include consideration of 25 year sea level rise for the 25 year design life. The wave and water level combinations provide the return period for the overtopping assessment. For stability assessments the extreme water levels have been considered with a depth limited wave as described in Section 4.3.1.

The significant wave height provided by JBA is referred to as H_s . For the purposes of design, where required, H_{m0} , the spectral significant wave height, is assumed to be equal to H_s .

Table 4.1: Design waves and water levels

Location	Name	H_s (m)	T_p (s)	Water Level
1	Great Porth (south of Great Carn)	1.12	8.53	3.23
2/3b*	Great Porth (north of Great Carn)	0.95	10.88	3.70
3	Stinking Porth	0.71	9.96	3.90
4	Great Popplestone	0.82	10.21	3.78
5	Kitchen Porth	0.80	10.37	3.43
8b	The Quay	1.49	11.30	3.65
9	Green Bay	0.37	8.07	3.98

* This is most severe wave and water level combination for overtopping at sites 2b and 3

Source: JBA

The location of the beach toes as defined by JBA, where the waves have been extracted, are illustrated in Figure 4.1.

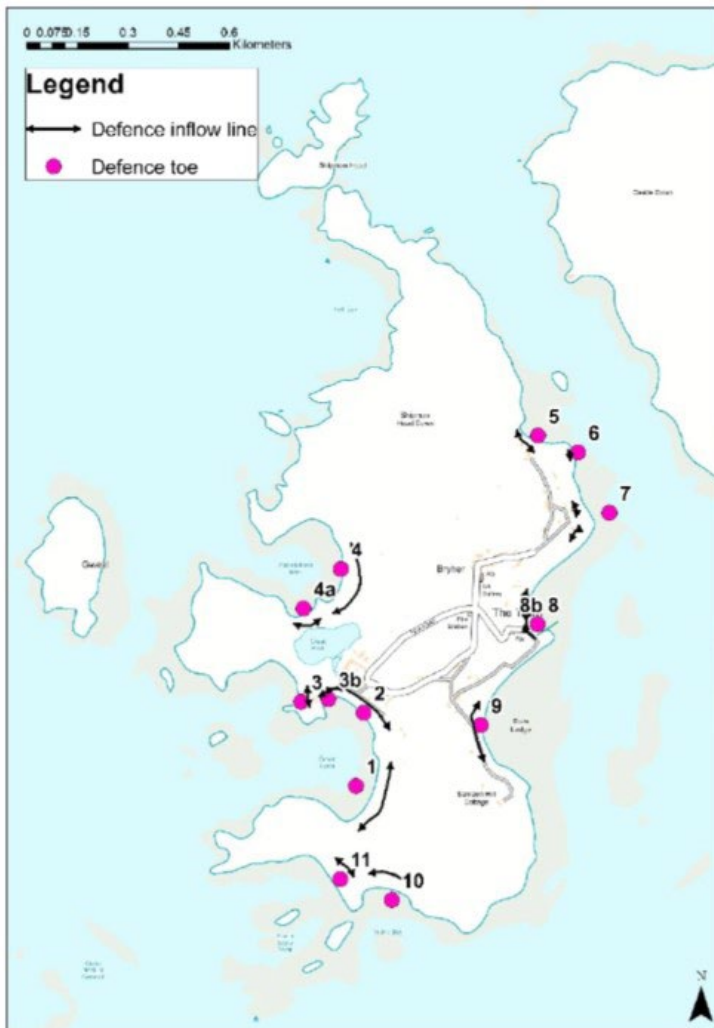

Figure 4.1: Location of wave extraction points

Source: Council of Isles of Scilly (OBC, 2020)

4.2 Codes and Standards

The codes and standards used in the design are listed below:

- British Standards, BS6349 suite, Maritime Structures;
- BS EN 1991-1-1:2002. Eurocode 1: Actions on structures - Part 1-1: General actions. BSI;
- BS EN 1992-1-1:2004. Eurocode 2: Design of Concrete Structures - Part 1-1: General rules. BSI;
- BS EN 1997-1:2004 Eurocode 7: Geotechnical design - Part 1: General rules. BSI;
- BS EN 13383 Parts 1 and 2 European Armourstone Specification;
- BS6349-1-2:2016: Maritime Works General. Code of Practice for Assessment of Actions.

In addition to the standards above, the following international guides for good practice have also been adopted:

- CIRIA; CUR; CETMEF, (2007). The Rock Manual. The Use of Rock in Hydraulic Engineering; (2nd Edition), London;
- CIRIA, (2010). Beach management manual. (2nd Edition), London. PUB C685;
- Geosystems Design Rules and Applications, CRC Press (2013);

- EurOtop II (2016) Wave overtopping of sea defences and related structures. Assessment Manual.
www.overtopping-manual.com.

4.3 Design assumptions

4.3.1 Waves

The RFP did not require wave modelling and instructed the tenderers to extract the required input data from “The Isles of Scilly Coastal Flood Modelling” (JBA for the EA, 2019).

Upon request, EA provided a first set of data, which was considered insufficient. A further more extensive set of data was subsequently provided. This was reviewed and design wave conditions were extracted.

As instructed by the Client, HR Wallingford have utilised the data provided from the above mentioned study. HR Wallingford has duly reviewed the information provided and confirms that they appear reasonable for short period waves. However, without access to the raw data, and repeating the full analysis, we note that HR Wallingford are unable to take responsibility for any existing data quality and quantity provided by others. The following text is repeated in Appendix A, but it is important that the basis of the design waves is understood.

The data supplied to HR Wallingford from the JBA modelling study consists of a sub-set of 10,000 years’ of modelled extreme conditions, which has been set-up for extreme overtopping conditions. This sub-set of data contains the combinations of wave and sea level parameters that give the largest overtopping rate, although not necessarily the largest wave heights. However, the method adopted to generate these data was developed by HR Wallingford (see for example Gouldby et. Al., 2017), and it is considered that a reliable estimate of the extreme wave heights at the site(s) could be determined from the data provided.

Two sets of data were provided:

- Defended
- Defended NPPF 2117.

Where NPPF stands for “National Planning Policy Framework”.

It is assumed that:

- “Defended” is the current day (2017) estimate of wave heights and overtopping rates with existing sea defences.
- “Defended NPPF 2117” is the 2117 estimate of wave heights and overtopping rates which includes a 10% increase in offshore wind speed and wave heights, though no adjustment seems to be made to the wave period to maintain the input wave steepness. Sea level rise from 2017 to 2117 is given as 1.037m. This seems to be consistent with guidance given for the higher central allowance for sea level rise as currently given in the following link:

<https://www.gov.uk/guidance/flood-risk-assessments-climate-change-allowances#sea-level-allowances>

The information for the relevant sites at Bryher were extracted from these datasets. As part of the present study, a SLR allowance has been included in the water level to update the data to present day water levels (@2021) and to calculate water levels in 2046 (25 years life).

It is assumed that the waves were provided at the toe of the relative structures, as set in JBA’s Report (JBA for the EA, 2019), for each location, refer Figure 4.1.

As part of this detailed design, the waves were then transformed to the toe of the designed structures and overtopping calculations were performed using these data.

The assessment of hydraulic stability requires the 1 in 45 year extreme wave conditions, which are not available for this project. The JBA waves are 1 in 45 year overtopping wave and water level combinations. Therefore waves at the toe of the structures have been calculated using a combined approach. Depth limited wave conditions for the 1 in 45 year return period were propagated to the toe of the structures, including 25 years of allowance for sea level rise.

Then the results were compared with the JBA waves at the toe of the structure. The comparison highlighted that the JBA waves were mostly lower. This could be explained by the fact that these were combined events waves/water levels, which provided the 45 years return period overtopping events. These combinations would not necessarily include the 45 years extreme wave conditions. Therefore, the sites on the east of the island used wave conditions derived from depth limited waves, calculated using the 1 in 45 extreme water level. For the western sites judgment was applied considering that some of the locations are more sheltered.

A 12 hour storm has been considered for the design of the rock armour proposed, this is representative of the storms experienced in the Isles of Scilly.

It should be noted that the design waves do not include the long period component (bimodal waves) that was most likely one of the main factors that caused much of the flooding during the 2014 storms. Therefore some engineering judgement has been applied with design decisions; for example, increasing the armour size. This is particularly evident in the images of overtopping event at Great Porth North.

4.3.2 Ground conditions

No previous ground investigation is currently available at or near the location of the proposed works. A site visit was carried out by HR Wallingford during June 2021. Based on the findings of the site visit, the beach at the sites of the proposed works generally comprised sand and cobbles from local igneous rock. Evidence of boulders placed in previous attempts to stabilise the area and prevent erosion has also been found.

The findings of the site visit suggest that the ground conditions are suitable to accommodate the proposed coastal protection works. However, due to the lack of geotechnical information, no assessment was carried out to verify this assumption. The suitability of the ground will need to be confirmed prior to construction.

The text in this document refers often to the erosion of “ram” along the coast of the Isles of Scilly. It is, therefore, considered helpful to give a brief description of the meaning of “ram” in the context of the Isles of Scilly.

During the last Ice Age a large glacier flowed southwards down the Irish Sea Basin. Some authors indicate that this reached as far as the northern extremities of Bryher, Tresco and St Martin's.

The northern glacial deposits contain flint eroded from the floor of the Irish sea. (...) The moraines at the north end of St Martins (Pernagie bar and White Island bar) provide visible evidence of the southern tip of this glacier. South of this ice limit, cold tundra conditions resulted in the accumulation of orange-brown deposits known locally as “ram”.

The text above has been extracted from:

<http://naturalhistoryofscilly.info.websitebuilder.prositehosting.co.uk/geology>.

The “ram” is also described by others as rockfall and slope deposit, two lithostratigraphic units of different ages. Some authors also call this as “Porthloo Breccia” (Brian John, 2018, Evidence of extensive ice cover on the Isles of Scilly, Quaternary Newsletter, N.146).

The above is intended as background information and is not to be relied on. The ground conditions will need to be verified with a site specific ground investigation prior to construction.

5 Design

Note - all design extents and details of transitions to existing levels are to be confirmed following detailed site surveys prior to construction works.

5.1 Site 1 – Great Porth (south of Great Carn) - DKR6499/210/D110; DKR6499/210/D310

The preliminary design identified revetment protection for an 81m length of the beach, from chainage 129 to 210 in the southern corner of the bay. The rear of the revetment crest will be graded to existing levels and a geomat will be placed to reinforce the surface whilst the vegetation establishes. This concept has been taken through to detailed design. Note that the final chainages are to be confirmed following the detailed topographical survey. The design undertaken here is for the overtopping volumes and hydraulic stability of the rock armour to meet the requirements set out in the design basis, refer Section 4 and Appendix A.

This beach is classed as a defence asset by the Environment Agency. In the September 2021 inspection of the defence assets, undertaken by the Plymouth Coastal Observatory (PCO), the condition of the defence was classified as 'Fair', which means that defects may affect the performance of the asset (see Figure 5.1 for the definition of condition grade in the EA's Condition Assessment Manual). The proposed works aim to enhance the performance of the asset and the level of protection.

Grade	Rating	Description
1	Very Good	Cosmetic defects that will have no effect on performance
2	Good	Minor defects that will not reduce the overall performance of the asset
3	Fair	Defects that could reduce the performance of the asset
4	Poor	Defects that would significantly reduce the performance of the asset
5	Very Poor	Severe defects resulting in complete performance failure

Figure 5.1: Definition of condition grade in the EA's Condition Assessment Manual

Source: Environment Agency (2014), Asset performance tools – asset inspection guidance, Report SC11008/R2

5.1.1 Overtopping assessment

The OBC (2020) report provided recommendations on the required increase in crest elevation at the project locations to mitigate flood risk. These recommendations were taken into account in the preliminary design. Since the OBC (2020) gave recommendations on an average increase in elevation, further overtopping calculations were required to make sure that the resulting crest elevation meets the design criteria. The JBA assessment used waves at the assumed defence toe level at each beach, so these waves have been transformed to the proposed toe of each defence using the Goda (2010) transformation method.

The identified design section has been schematised and a desk assessment has been carried out with wave overtopping calculated by using the wave overtopping formulae presented in EurOtop II, at a typical cross section. Wave attack with the transformed wave has been assumed to be orthogonal to the typical section and no obliquity is included.

Appropriate roughness factors (γ_f) have been applied for the different proposed sections as recommended in EurOtop II, at Great Porth a conservative roughness γ_f of 0.6 was adopted for rock armour considering the impermeable core.

As discussed in the design bases, refer Appendix A of this report, criteria for overtopping set a limit for mean overtopping of 5 l/m/s for the 1:45 year storm as ultimate limit state to minimize damage and avoid failure of the banks and of 1 l/m/s for the 1:1 year storm as a serviceability limit state, considering that pedestrian access behind the beach is likely even though discouraged, to minimize erosion of the crests.

The calculated mean overtopping discharges for the selected crest elevations are presented in Table 5.1.

Table 5.1: Site 1 – Great Porth (south of Great Carn) crest height design

Return Period		Wave at structure's toe		Water level (mOD)	Toe level (mOD)	Selected crest level (mOD)	Mean Overtopping (l/m/s)
(yr)	Wave Point	H _s (m)	T _p (s)				
45	1	0.9	8.5	3.2	1.9	6.5	<0.01
1	1	0.8	5.9	3.2	1.9	6.5	<0.01

5.1.2 Hydraulic stability

Design of primary rock armour protection has been undertaken based on the Van der Meer equations, considering shallow foreshores, as recommended in the Rock Manual (CIRA, CUR, CETMEF 2007).

Waves and water level conditions for the 1:45 year event were used for the rock size calculation, considering a 25 year life, as also discussed in Section 4.3.1 and Appendix A.

A nominal permeability factor $P = 0.1$ for the revetment has been adopted for the design in accordance with (CIRIA, CUR, CETMEF, 2007).

Table 5.2: Rock armour design parameters for Great Porth South

Parameter	Symbol	Value
H _s at the toe of the structure	H _s	1.76m
H _{2%} at the toe of the structure	H _{2%}	2.36m
T _p	T _p	10s
Water depth at the toe	d	2.1m
Density of sea water	ρ _s	1,030 kg/m ³
Density of rock*	ρ _r	2,600 kg/m ³
Relative eroded area	S _d	2
N _o of waves in 12-hour storm	N _z	(12 x 3600) / T _m
N _o of rocks comprising layer	-	2
Slope of structure		1 in 3
Notional permeability	P	0.1

* The rock density used was agreed with the Client, given the availability

Standard gradings conforming to BS EN 13383 have been selected based on the M₅₀ identified by these calculations.

Van der Meer's prediction method is usually based on use of H_s, but for shallow water (depth-limited) conditions, Van Gent et al. (2004) recommended modifications to the formulae that use H_{2%} for depth-limited foreshores:

$$\frac{H_{2\%}}{\Delta D_{n50}} = 8.4 \cdot P^{0.18} \cdot \left(\frac{S_d}{\sqrt{N}} \right)^{0.2} \cdot \xi_{s-1,0}^{-0.5}$$

for plunging waves ($\xi_m < \xi_{cr}$)

$$\frac{H_{2\%}}{\Delta D_{n50}} = 1.3 \cdot P^{-0.13} \cdot \left(\frac{S_d}{\sqrt{N}} \right)^{0.2} \cdot \sqrt{\cot \alpha} \cdot \xi_{s-1,0}^P \quad \text{for surging waves } (\xi_m > \xi_{cr})$$

The input parameters for both formulae are as follows:

- H_s = Significant wave height at the toe of the structure, [m]
- $H_{2\%}$ = Calculated using Battjes & Groenendijk method (2000), [m]
- T_m = Mean wave period at the toe of the structure, [s]
- $T_{m-1,0}$ = (Spectral) mean energy wave period at the toe of the structure, [s]
- Δ = Relative buoyant density, $(\rho_r / \rho_w) - 1$
- ρ_r = Rock armour density, [t/m³]
- ρ_w = Water density, [t/m³]
- D_{n50} = Nominal diameter of armour unit [m]
- α = Slope angle
- P = Notional permeability of the structure
- N = Number of incident waves at the toe
- S_d = Damage parameter

ξ_m = Surf similarity parameter using mean wave period T_m [s]:

$$\xi_m = \frac{\tan \alpha}{\sqrt{2\pi H_s / g T_m^2}}$$

$\xi_{m-1,0}$ = Surf similarity parameter using (spectral) mean energy wave period $T_{m-1,0}$ [s]:

$$\xi_{m-1,0} = \frac{\tan \alpha}{\sqrt{2\pi H_s / g T_{m-1,0}^2}}$$

ξ_{cr} = Critical surf similarity parameter:

$$\xi_{cr} = \left(\frac{8.4}{1.3} \cdot P^{0.31} \cdot \sqrt{\tan \alpha} \right)^{\frac{1}{P+0.5}}$$

The resulting M_{50} for the primary armour at the typical sections is $M_{50}=2130\text{kg}$, therefore a standard grading of 1 to 3t is selected for this site.

The armour would be rough, angular rock and the quality of rock required will be specified in accordance with the European Armourstone Specification BS EN 13383 Parts 1 and 2, with a slope of 1V:3H.

Size distribution and specification of limit masses of a standard grading are given in Table 5.3 with the following definitions:

- ELL (Extreme Lower Limit) – the mass below which no more than 5 per cent passing by mass is permitted;
- NLL (Nominal Lower Limit) – the mass below which no more than 10 per cent passing by mass is permitted;

- NUL (Nominal Upper Limit) – the mass below which no less than 70 per cent passing by mass is permitted;
- EUL (Extreme Upper Limit) – the mass below which no less than 97 per cent passing by mass is permitted.

Table 5.3: Size distribution for 1-3t (standard grading)

ELL (kg)	NLL (kg)	NUL (kg)	EUL (kg)
700	1000	3000	4500

Source: HR Wallingford

A thickness coefficient (k_t) value of 0.9 was adopted and with 2 layers of rock, a minimum layer thickness of 1.6 m is required for 1 - 3 tonne rock armour. This calculation is included in Appendix B.

The crest width is to be a minimum 3 rocks wide ($3D_{n50}$) and the toe min 2 rocks wide ($2D_{n50}$) (to minimize footprint).

The toe scour protection was assessed using Sutherland (2006) formulae using both the JBA waves and the depth limited waves transformed to the proposed structure toe. This formulae estimates a potential scour and 0.5m. The typical section provides a buried toe depth of 1.05m and a minimum depth of 1m is stated on the drawings.

5.1.3 Filter layer & geotextile

An rock filter underlayer is to be placed under the rock armour to provide a base for the armour to be placed on and aid interlock. A geotextile is also to be placed under the filter layer to prevent migration of sand through the revetment whilst ensuring permeability. The filter layer helps reduce the volume of rock armour required to achieve the required crest height and also reduces the risk of puncture of the geotextile during placement of the large rock.

The grading of the rock is to meet the filter criteria set out in the CIRIA Rock Manual. For the 1 to 3 tonne armourstone grading, a 40-200 kg filter has been selected.

The geotextile is to ensure permeability but have pore sizes sufficient to prevent clogging with fill material or prevent migration of material through the fabric. The geotextile must also be durable enough to survive handling and installation and withstand UV exposure.

Assuming a mix of sand and shingles as a bed, the following characteristics have been used to select a geotextile:

- Particle size $D_{50} = 2\text{mm}$
- Permeability $k_s = 1 \times 10^{-3} \text{ m/s}$.

Using design charts from Geofabrics, a HPS geotextile HPS 12 has been selected based on its permeability. Checks on the durability and retention have confirmed this product, see Appendix G for the product details, similar approved products from other suppliers can also be used. Further details on geotextile properties are included in the project specifications.

5.1.4 Geomat

To help stabilise the rear of the crest whilst vegetation establishes, geomattng is proposed. A product, Robulon by Tencate has been identified with details contained in Appendix G. This is to be laid and pinned as per the manufacturers requirements and a minimum of 300mm cover of topsoil/fill is required. The extent of the matting is shown on the drawings and general requirements for geotextiles and geomattng are included in the project specifications.

5.1.5 Design section and tie in to existing ground

The typical section for the revetment is included as Figure 5.2 below. The section at chainage 160 has been taken as the representative section; refer to the general arrangement drawing in Appendix C for the chainages. Detailed sections along the extent of the works have not been produced, as detailed topographic data are not available. It is expected that the Contractor will develop detailed sections along this frontage to pick up how the existing profile varies.

At the northern end of the revetment, the rock toe is to extend and wrap around the crest and is to be buried. The rock at the south will tie into the ram face. The Contractor will need to confirm these tie in details following detailed topographic surveys. The existing rock along this beach is to be stripped, stockpiled and placed as required.

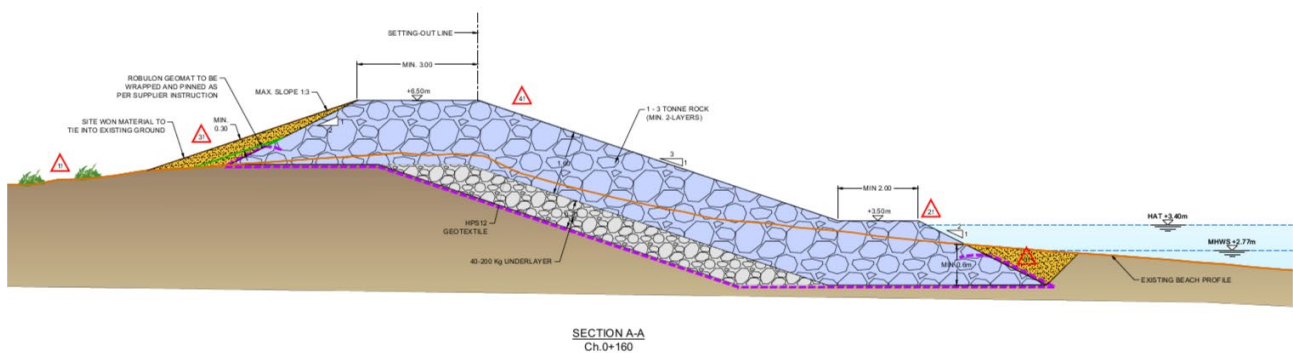

Figure 5.2: Site 1 – Great Porth (south of Great Carn) typical section

5.2 Site 2/3b – Great Porth (north of Great Carn) (DKR6499/210/D111; DKR6499/210/D320; DKR6499/210/D321; DKR6499/210/D322; DKR6499/210/D323; DKR6499/210/D324)

To the north of Great Carn, a 90m length of beach was identified in the preliminary design as benefiting from an increase in crest height and a rock revetment was the design solution proposed. This would tie into the existing revetment at the very north of the beach which helps protect the access to the property at the western extent of the bay. This revetment will protect the lowest crest levels along this beach and will limit overtopping volumes and protect the Great Pool behind from excess inundation. A revetment was constructed in 1994/95 along the northern limit of the beach and the proposed new revetment will tie into this; noting from the profiles that the existing revetment has reshaped significantly at some sections. The design profile of the revetment, B2989/04 Rev 0, has been taken as the target profile for the new revetment and this compared well to the existing slope crest alignment based on LiDAR which has been assumed as the revetment design crest location. The new revetment is proposed to sit over the toe of the previous revetment.

The length of beach to the south of the existing built revetment, approximately southwards from chainage 170 (see Drawing DKR6499/210/D111), incorporates a slipway which is to be retained, but as its crest is lower than the proposed crest levels, a temporary flood barrier is to be installed here. This is to be a demountable barrier that, it is assumed, can be installed with the resources available at this location. Suitable concrete blocks are to be provided for the gate brackets to be fixed to.

Ten metres to the south of the slipway, the existing beach crest levels rise up and the rock revetment would tie into this area into existing levels. It is noted that although the crest levels from the south of the slipway to

the boat house gallery are higher, this section of the beach is also very exposed and has previously been overtopped during storm events. HR Wallingford recommend that in the near future a similar revetment protection is extended along this section to tie into the gallery. However given the available budget, and the existing crest elevations and following discussions with the Client the extent to the north is prioritised to be protected at this time.

While protection along the stretch between the slipway and the Studio is not being provided under these works, an option to re-landscape/reprofile part of the access track behind the crest near to the slipway access (locally increase the elevation with a hump) was put forward to the Client. This would provide a sort of small initial barrier to flows along the track to limit ingress into the Great Pool drainage channel and pool itself. However, it was concluded that this proposal could be considered local works and it is not included in this design.

This beach is also classed as a defence asset by the Environment Agency. In the September 2021 inspection of the defence assets, undertaken by the Plymouth Coastal Observatory (PCO), the condition of the defence was classified as 'Fair' (see Figure 5.1 for the definition of condition grade in the EA's Condition Assessment Manual). The proposed works aim to enhance the level of protection of this asset. The slipway is not identified as a separate asset.

There is an existing outfall that drains the Great Pool. This asset is classed as 'poor', however any further description of the reasons for the classification are not available. The Client has indicated that this outfall will not be modified as part of these works, so no changes to the pipe or surround are proposed and it will be part covered with new rock armour.

5.2.1 Overtopping assessment

The overtopping methodology is as set out in Appendix A and Section 5.1 above. The proposed works are located in between JBA Waves Points 2 and 3b and so both waves were considered to ensure that the most severe design case was selected and these were transformed to the structure toe. The results along with the required crest height are presented in Table 5.4. The proposed flood gate at the crest of the slipway has also had the overtopping calculated considering the wave at Point 2, the overtopping is larger here but still within acceptable values. The slipway slope has considered a roughness of 1 considering the concrete ramp.

Table 5.4: Site 2/3b – Great Porth (north of Great Carn) crest height design

Return Period (yr)	Wave Point	Wave at structure's toe		Water level (mOD)	Toe level (mOD)	Selected crest level (mOD)	Mean Overtopping (l/m/s)
		Hs (m)	Tp (s)				
45	2	0.9	10.9	3.7	2.3	6.0	1.0
1	2	0.7	8.4	3.5	2.3	6.0	<0.01
45	3b	1.0	10.0	3.9	2.3	6.0	2.4
1	3b	0.6	6.3	3.4	2.3	6.0	<0.01
45	2 – Flood gate	0.9	10.9	3.9	2.3	4.2* + 0.9m wall	3.4
1	2 – Flood gate	0.7	8.4	3.4	2.3	4.2* + 0.9m wall	<0.01

* existing crest level of slipway is assumed @ 4.2 mOD

5.2.2 Hydraulic stability

The design methodology for the assessment of rock armour is set out in Section 5.1.2. Table 5.5 below shows the parameters used for calculation of the rock size for this revetment.

Table 5.5: Rock armour design parameters for Great Porth North

Parameter	Symbol	Value
H _s at the toe of the structure	H _s	1.5m
H _{2%} at the toe of the structure	H _{2%}	2.0m
T _p	T _p	10s
Water depth at the toe	d	1.7m
Density of sea water	ρ _s	1,030 kg/m ³
Density of rock*	ρ _r	2,600 kg/m ³
Relative eroded area	S _d	2
N _o of waves in 12-hour storm	N _z	(12 x 3600) / T _m
N _o of rocks comprising layer	-	2
Slope of structure		1 in 2.5
Notional permeability	P	0.1

* The rock density used was agreed with the Client, given the site availability

The resulting M₅₀ for the primary armour at the typical sections is M₅₀=1630kg, therefore a standard grading of 1 to 3t is selected for this site, with the same layer thickness criterion and crest and toe widths as confirmed in Section 5.1.2. The calculation is included in Appendix B.

The armour would be rough, angular rock and the quality of rock required will be specified in accordance with the European Armourstone Specification BS EN 13383 Parts 1 and 2, with a slope of 1V:2.5H, to merge into existing revetment.

No rock filter layer is to be included here to reduce the amount of excavation needed, but a geotextile to prevent migration of sands and fines through the rock is to be placed under the rock. The same methodology as set out in Section 5.1.3 applies and to provide further protection against puncturing during rock placement a HPS 12 geotextile by Geofabrics, or similar approved product, has been selected.

The toe scour protection was assessed using Sutherland (2006) formulae using both the JBA and depth limited waves transformed to the proposed structure toe. This formulae estimates the potential scour and 0.6m was calculated. The typical section provides a buried toe depth of 0.94m and a minimum of 0.8m is to be provided along the frontage.

5.2.3 Flood gate

A demountable flood barrier is to be provided at the top of the existing slipway at Chainage 140. This is to be a barrier capable of being installed manually by one individual with no specialist equipment. The barrier is to have panels that will slot into place to provide a temporary barrier to overtopping waves. HR Wallingford understand that the Council of the Isles of Scilly are familiar with these barriers and so their operation is understood. Appropriate training will need to be provided for the user once installed.

The exact width of the slipway is to be confirmed, by topographic survey, but a width of 3.6m has been assumed based on the available data. The crest level of the slipway is around +4.75mOD and three 300 mm high panels are proposed to bring the crest level to +5.65 mOD. This is a lower level than the revetment crest but overtopping calculations confirm acceptable volumes.

There are no available drawings or details of the slipway but photographs indicate a concrete slab edged with rock. It is proposed to retain this and install the gates and supports above the sloped slipway on the

The supplier will provide the relevant specification and installation details for the gate fixing mounts and central post, refer to the drawings in Appendix C for the proposed details for the foundations and supports and example details of the gate fixings. A demountable flood barrier by Flood Control International (<https://floodcontrolinternational.com/>) has been selected as its 300mm high panels can easily be installed by one person. Other products can be proposed for approval by the Engineer and these need to have been tested to PAS 1188 flood protection requirements where appropriate. Information on the proposed barrier is included as Appendix G.4.

5.2.4 Great Pool outfall

The existing outfall passes through the revetment at the north of the beach and no works to the pipe or the concrete surrounds are to be undertaken as part of this contract. The existing arrangement is shown in the design drawing B2989/04 Rev 0 with the pipe and concrete surround sitting on a mass concrete haunch over the ram with rock placed over the top. It must be noted that this drawing is a design and not an as-built drawing, and the outfall location was moved from the location shown. The drawing is considered as indicative of the intent of the works.

The concrete surround is assumed to be in reasonable condition, and to fit into the new profile, existing rocks may need to be stripped before the new rock is placed. Contractor to survey the outfall ahead of installation and rocks are to be placed individually on and around the concrete surround. Refer to drawing DKR6499-210-D320 in Appendix C for a section through the outfall. It has been assumed that the levels in the design drawing need to be adjusted to allow for the shift in Scilly Ordnance Datum to national Ordnance Datum. The levels in drawing B2989/04 Rev 0 were therefore increased by 360mm. The section through the outfall, where the typical section has been adjusted is shown in .The Contractor is to survey the outfall and confirm the levels and how it fits into the design section prior to any works.

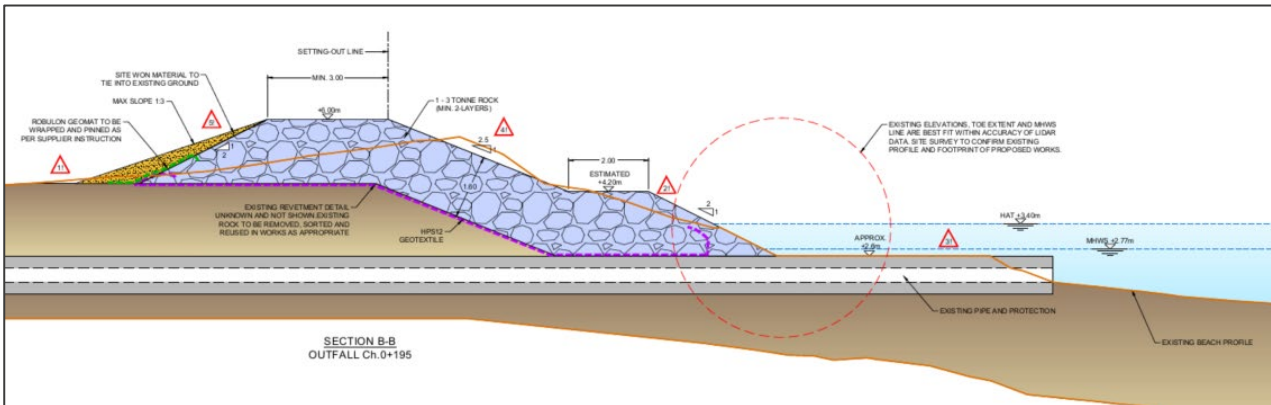

Figure 5.4: Site 2/3b – Section through Great Pool outfall

It is important to highlight that at Great Par North also a buried pipe exists, which we assume is the unknown sewage pipe marked on provided drawings for the revetment (see Ref.12 in Table 3.1). Both the outfall and the buried pipe are indicated on the drawings.

5.2.5 Design section and tie in to existing ground

A geomat has been included on the rear slope of the fill to help stabilise the slope whilst vegetation establishes itself, Robulon by Tencate has been selected as per the other sites.

The typical section for the Site 2/3b works is included as Figure 5.5. This is a representative section taken from the LiDAR profiles. This section is taken at Chainage 180; refer to general arrangement drawing in

Appendix C for the chainages. A typical section approach has been produced as the detailed site topographic survey is not available. It is expected that the Contractor develops cross sections along the proposed frontage to confirm the sections along the full length.

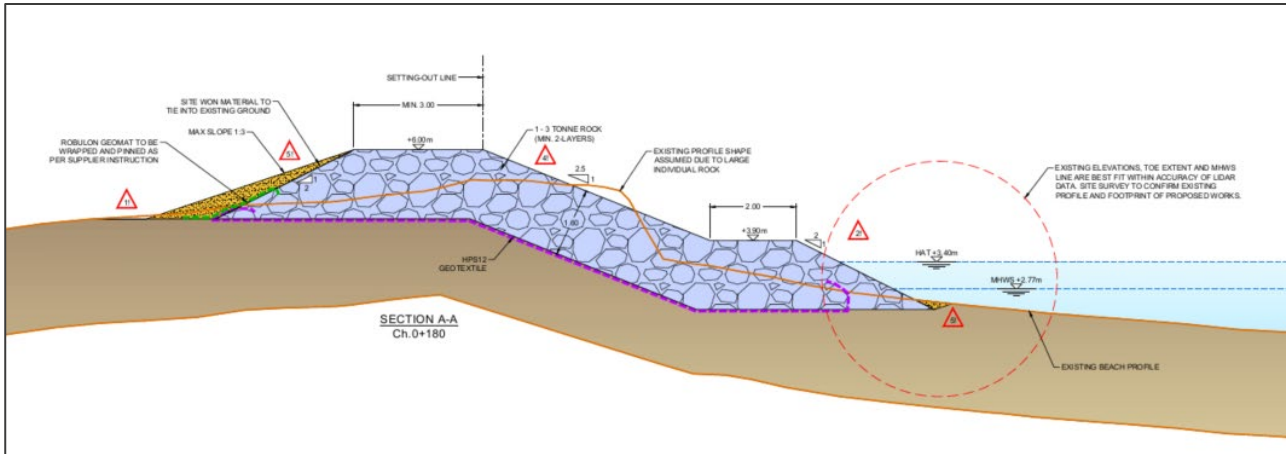

Figure 5.5: Site 2/3b – Great Porth (north of Great Carn) typical section

The revetment to the south is to tie into the higher ground levels and the toe should be wrapped around the structure and buried. The northern extent is to tie into the existing revetment. These details are included in the layout in drawing DKR6499-210-D111 and the Contractor is to confirm the tie ins once site surveys have been carried out. The existing rock is to be stripped, stockpiled and placed as required.

5.3 Site 3 – Stinking Porth (DKR6499/210/D112; DKR6499/210/D330)

The revetment proposed in the preliminary design has been taken forward to detailed design. This is a 55 m stretch in the centre of the bay where the embankment protects the Big Pool immediately behind. The design has been developed from preliminary stage to tie into the rock outcrop to the south in front of the Carn Leigh garden wall.

To help further protect to the north of the proposed revetment, the existing grassland could be landscaped to locally increase levels and provide a barrier to overtopping flows to further protect the Great Pool. As with the suggestion for site 2/3b, this is not included in the design but is a soft proposal that could be considered in addition to the construction of the revetment.

This beach is classed as a defence asset by the Environment Agency. In the September 2021 inspection of the defence assets, undertaken by the Plymouth Coastal Observatory (PCO), the condition of the defence was classified as 'Fair' (see Figure 5.1 for the definition of condition grade in the EA's Condition Assessment Manual). The proposed works aim to enhance the level of protection of this asset.

5.3.1 Overtopping assessment

The overtopping methodology is as set out in Appendix A and Section 5.1 above. The waves at JBA Point 3 were transformed to the structure toe. The results and design crest height are presented in Table 5.4 and the calculation for this site is included in Appendix B.

Table 5.6: Site 3 – Stinking Porth crest height design

Return Period (yr)	Wave Point	Wave at structure's toe		Water level (mOD)	Toe level (mOD)	Selected crest level (mOD)	Mean Overtopping discharge (l/m/s)
		H _s (m)	T _p (s)				
45	3	1.31	9.3	3.78	2.3	6.5	2.2
1	3	0.99	10.0	3.42	2.3	6.5	0.2

5.3.2 Hydraulic stability

The design methodology for the assessment of rock armour is set out in Section 5.1.2. Table 5.5 below shows the parameters used for calculation of the rock size for this revetment.

Table 5.7: Rock armour design parameters for Stinking Porth

Parameter	Symbol	Value
H _s at the toe of the structure	H _s	1.4m
H _{2%} at the toe of the structure	H _{2%}	1.9m
T _p	T _p	10s
Water depth at the toe	d	1.6m
Density of sea water	ρ _s	1,030 kg/m ³
Density of rock*	ρ _r	2,600 kg/m ³
Relative eroded area	S _d	2
N _o of waves in 12-hour storm	N _z	(12 x 3600) / T _m
N _o of rocks comprising layer	-	2
Slope of structure		1 in 2
Notional permeability	P	0.1

* The rock density used was agreed with the Client, given the site availability

The resulting M₅₀ for the primary armour at the typical sections is M₅₀=1900kg, therefore a standard grading of 1 to 3t is selected for this site, to be consistent with rest of the island. The calculation is included in Appendix B.

The armour would be rough, angular rock and the quality of rock required will be specified in accordance with the European Armourstone Specification BS EN 13383 Parts 1 and 2, with a slope of 1V:2H.

The toe scour protection was assessed using Sutherland (2006) formulae using the JBA and depth limited waves transformed to the proposed structure toe. This formulae estimates the potential scour and 1.1m was calculated. The typical section provides a buried toe depth of 1.4m and a minimum of 1m is to be provided along the protection.

5.3.3 Filter layer & geotextile

A rock filter underlayer is to be placed under the rock armour to provide a base for the armour to be placed on and aid interlock. A geotextile is also to be placed under the filter layer to prevent migration of sand through the revetment whilst ensuring permeability. The filter layer and geotextile methodology is as set out in Section 5.1.3. For 1 to 3 tonne armourstone grading, a 40-200 kg filter has been selected with a HPS12 geotextile from Geofabrics.

5.3.4 Design section and tie into existing ground

A geomat has been included on the rear slope of the fill to help stabilise the slope whilst vegetation establishes itself, Robulon by Tencate has been selected as per the other sites.

The typical section for the Site 3 works is included as Figure 5.6. This is a representative section taken from the LiDAR profiles. This section is taken at Chainage 140 refer to general arrangement drawing in Appendix C for the chainages. A typical section has been produced as the detailed site topographic survey is not available. It is expected that the Contractor develops cross sections along the proposed frontage to confirm the sections along the full length.

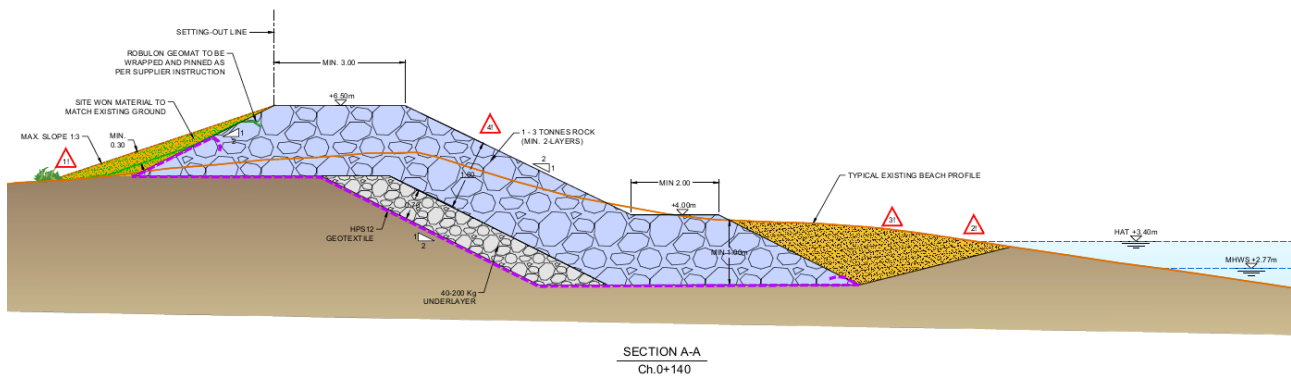

Figure 5.6: Site 3 – Stinking Porth typical section

The revetment to the south is to slope down to meet the rock outcrop in front of Carn Leigh garden and the Contractor is to extend the rock and tie in to site conditions. To the north, the rock toe is to wrap around the crest and be buried as required. Again the Contractor is to confirm the tie in extents following the site topographic surveys. Existing rock on the beach is to be stripped, stockpiled and reused as required.

5.4 Site 4 – Great Popplestone (DKR6499/210/D113; DKR6499/210/D340)

The revetment proposed in the preliminary design has been taken forward to detailed design. This is a 100 m stretch in the centre of the bay where the embankment protects the Big Pool immediately behind. The preliminary design included the raising of the wall, on review of the condition of the wall this extension is no longer proposed as the integrity of the existing structure is not known. A wide raised rock armour crest will instead help protect and reduce overtopping.

The beach is classified as two defence assets by the Environment Agency, one includes the wall at the southern end of the bay and the second to the northeast where the embankment behind is higher. The proposed works extend over both assets and in the September 2021 inspection, undertaken by the Plymouth Coastal Observatory (PCO), the wall defence has been classified as 'poor' but the weighted assessment is 'fair'. The section to the north east is classified as 'fair' (see Figure 5.1 for the definition of condition grade in the EA's Condition Assessment Manual). The proposed works aim to enhance the level of protection of these assets.

The extent of the wall to the northern end of the proposed protection is not clear from the data available so the Contractor will need to survey and confirm the wall extents and tie into existing ground as appropriate.

5.4.1 Overtopping assessment

The overtopping methodology is as set out in Appendix A and Section 5.1 above. The waves at JBA Point 4 were transformed to the structure toe. The crest level is taken as the height of the wall taken from the LiDAR data. The results and design crest height are presented in Table 5.8. As stated in Section 4.3.1, these design waves give small overtopping volumes, but it is noted that large rocks (and assumed overtopping volumes) washed over the wall in the 2014 storms and the long period wave components noted for the storms are not included in the wave outputs, as there is no reliable methodology for predicting overtopping from bimodal waves, and so the proposed protection is expected to give additional protection against overtopping from these waves.

Table 5.8: Site 4 – Stinking Porth crest height design

Return Period (yr)	Wave Point	Wave at structure's toe		Water level (mOD)	Toe level (mOD)	Selected crest level (mOD)	Mean Overtopping (l/m/s)
		H _s (m)	T _p (s)				
45	4	0.72	9.5	3.43	3	5.0	<0.1
1	4	0.60	7.3	3.33	3	5.0	<0.1

5.4.2 Hydraulic stability

The design methodology for the rock armour is set out in Section 5.1.2. Table 5.9 below shows the parameters used for calculation of the rock size for this revetment.

Table 5.9: Rock armour design parameters for Great Popplestone

Parameter	Symbol	Value
H _s at the toe of the structure	H _s	1.0m
H _{2%} at the toe of the structure	H _{2%}	1.5m
T _p	T _p	10s
Water depth at the toe	d	1.0m
Density of sea water	ρ _s	1,030 kg/m ³
Density of rock*	ρ _r	2,600 kg/m ³
Relative eroded area	S _d	2
No of waves in 12-hour storm	N _z	(12 x 3600) / T _m
No of rocks comprising layer	-	2
Slope of structure		1 in 3
Notional permeability	P	0.1

* The rock density used was agreed with the Client, given the site availability

The resulting M₅₀ for the primary armour at the typical sections is M₅₀=450kg, though in line with the standardisation of rock armour elsewhere, and considering the long period waves, an increase to a 1 to 3 tonne standard grading is selected. The calculation is included in Appendix B.

This rock should be placed in a minimum of two layers with the same layer thickness criterion and crest width as set out in Section 5.1.2, the toe is to tie into existing ground levels. The existing rock may need to be reprofiled ahead of placement of the new rock and larger existing rock can be reused in the defence.

The armour would be rough, angular rock and the quality of rock required will be specified in accordance with the European Armourstone Specification BS EN 13383 Parts 1 and 2, with a slope of 1V:3H, to merge into existing revetment.

The potential scour here was assessed considering the approach from Powell & Lowe (1994) considering the beach as a shingle beach in front of vertical walls. The rock here is overlaying and tying into existing revetment and a very small scour depth of 0.06m was estimated.

5.4.3 Design section and tie into existing ground

Two typical sections for the Site 4 works have been produced to illustrate the different ground levels behind the defence. These are included as Figure 5.7. These are representative sections taken from the LiDAR profiles. The sections taken are at Chainage 120 and Chainage 160 considering the different levels behind; refer to general arrangement drawing in Appendix C for the chainages. A typical section has been produced as the detailed site topographic survey is not available. It is expected that the Contractor develops cross sections along the proposed frontage to confirm the sections along the full length. The exact termination of the wall to the north east is not known, the Contractor is to verify ahead of construction and is to tie into the existing revetment to fit the existing profiles.

Existing rock should be removed ahead of placement of the 2 armour layers and suitable rocks should be reused in the profile.

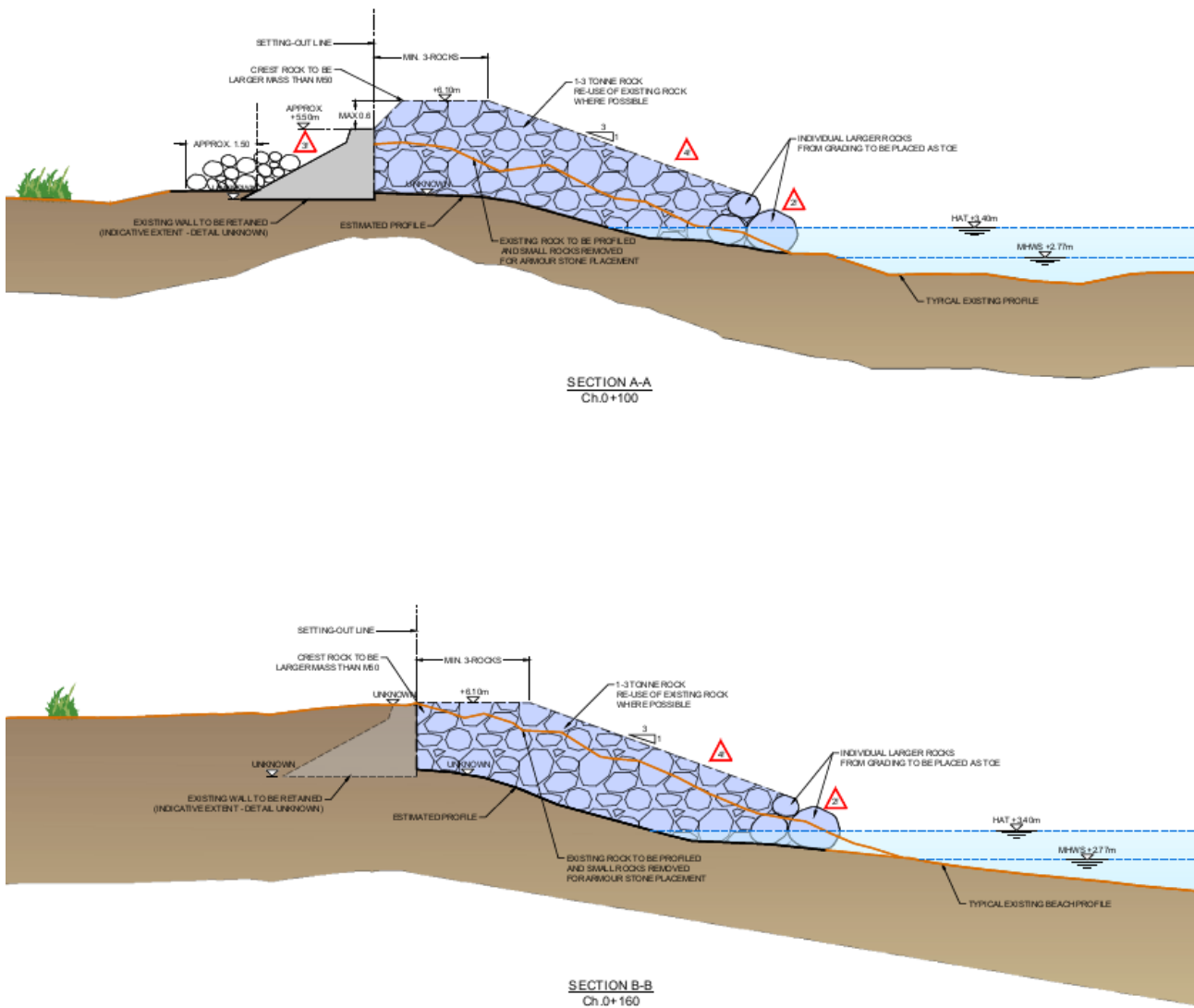

Figure 5.7: Site 4 – Great Popplestones typical sections

5.5 Site 5 – Kitchen Porth (DKR6499/210/D114; DKR6499/210/D350)

The revetment proposed in the preliminary design has been extended during detailed design to tie into the rocks that form the eastern limit of the beach. This now has a 40 m long crest and slopes down to tie into existing levels at each end. This is to be a rock bank protection rather than a formal revetment to protect the ram and will match current crest levels. To terminate the revetment the rock is to tie into the existing bank to the north and into the rock outcrop to the south as illustrated in the layout (DKR6499/210/D114).

This beach is also classed as a defence asset by the Environment Agency. In the September 2021 inspection of the defence assets, undertaken by the Plymouth Coastal Observatory (PCO), the condition of the defence was classified as 'Fair' (see Figure 5.1 for the definition of condition grade in the EA's Condition Assessment Manual). The proposed works aim to enhance the level of protection of this asset.

5.5.1 Overtopping assessment

The proposed rock recharge is to tie into existing crest levels, as such no overtopping assessment has been used to define the crest level. The focus was on providing a stable rock armour protection to tie in with the existing level to protect the exposed ram.

5.5.2 The hydraulic stability

The design methodology for the rock armour is set out in Section 5.1.2.

Table 5.10 below shows the parameters used for calculation of the rock size for this revetment. The depth limited wave was used here.

Table 5.10: Rock armour design parameters for Kitchen Porth

Parameter	Symbol	Value
H _s at the toe of the structure	H _s	0.8m
H _{2%} at the toe of the structure	H _{2%}	1.2m
T _p	T _p	11.3s
Water depth at the toe	d	0.6m
Density of sea water	ρ _s	1,030 kg/m ³
Density of rock*	ρ _r	2,600 kg/m ³
Relative eroded area	S _d	2
N _o of waves in 12-hour storm	N _z	(12 x 3600) / T _m
N _o of rocks comprising layer	-	2
Slope of structure		1 in 2
Notional permeability	P	0.1

* The rock density used was agreed with the Client, given the site availability

The resulting M₅₀ for the primary armour at the typical sections is M₅₀=320kg, though in line with the standardisation of rock armour elsewhere, and considering the long period waves, an increase to a 1 to 3 tonne standard grading is selected. The calculation is included in Appendix B.

This rock should be placed in a minimum of two layers with the same layer thickness criterion and crest width as set out in Section 5.1.2. The existing rock may need to be removed or reprofiled ahead of placement of the new rock and larger existing rock can be reused in the defence.

The armour would be rough, angular rock and the quality of rock required will be specified in accordance with the European Armourstone Specification BS EN 13383 Parts 1 and 2, with a slope of 1V:2H.

The potential scour here was assessed using Sutherland (2006) approach.

5.5.3 Design section

The typical section for the Site 5 works is included as Figure 5.8. This is a representative section taken from the LiDAR profiles. This section is taken at Chainage 180; refer to general arrangement drawing in Appendix C for the chainages. A typical section has been produced as the detailed site topographic survey is not available. Following topographic survey at construction stage, it is expected that the Contractor develops cross sections along the proposed frontage to confirm the sections and rock extent along the full length as well as confirming the tie in to existing ground at each end.

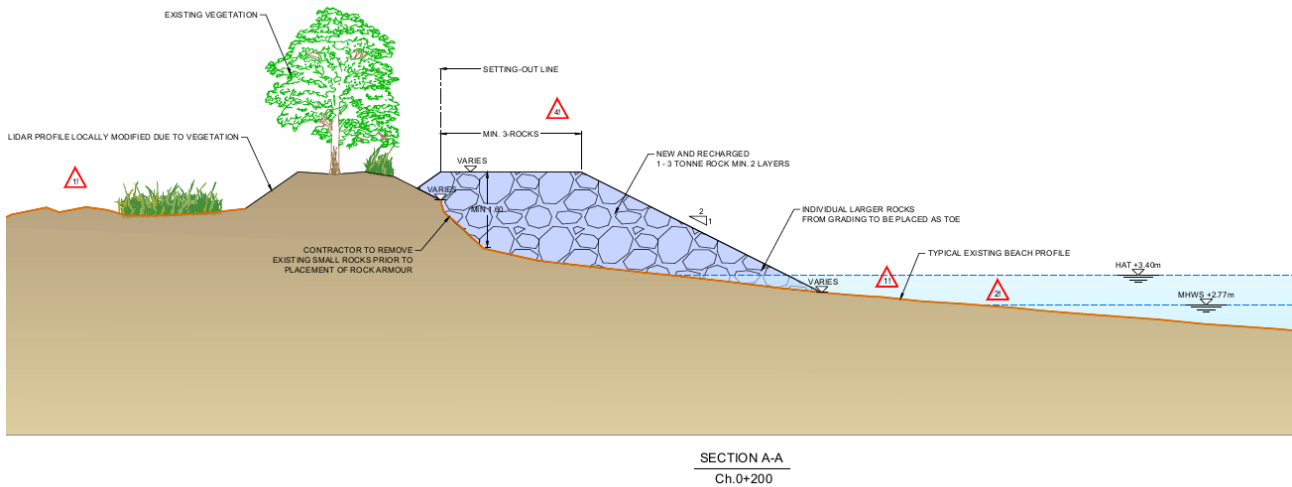

Figure 5.8: Site 5 – Kitchen Porth typical section

5.6 Site 8 – The Quay – (DKR6499/210/D115; DKR6499/210/D360)

At the quay, a small rock groyne was proposed at the preliminary design stage to protect the corner of the beach where it meets the quay from wave erosion. Placing rock in this corner was not preferred as this is an informal access point to the beach and from a health and safety perspective accessing over a rock revetment should not be encouraged.

The groyne length has been reduced during the detailed design to a 5m long crest, this is to minimise risk of any erosion on the landside of the groyne and is still adequate to protect the corner of the beach from wave action.

This beach and quay are classed as defence assets by the Environment Agency. In the September 2021 inspection of the defence assets, undertaken by the Plymouth Coastal Observatory (PCO), the condition of the dune was classified as ‘fair’ and the quay as ‘good’ (see Figure 5.1 for the definition of condition grade in the EA’s Condition Assessment Manual). The proposed works aim to enhance the level of protection of the dune.

5.6.1 Hydraulic stability

The design methodology for the groyne rock armour is set out in Section 5.1.2.

Table 5.11 below shows the parameters used for calculation of the rock size for this revetment. The transformed JBA waves were used as the western location of the beach is sheltered.

Table 5.11: Rock armour design parameters for the Quay

Parameter	Symbol	Value
H _s at the toe of the structure	H _s	0.4m
H _{2%} at the toe of the structure	H _{2%}	0.5m
T _p	T _p	8.1s
Water depth at the toe	d	2.7m
Density of sea water	ρ _s	1,030 kg/m ³
Density of rock*	ρ _r	2,600 kg/m ³
Relative eroded area	S _d	2
N _o of waves in 12-hour storm	N _z	(12 x 3600) / T _m
N _o of rocks comprising layer	-	2
Slope of structure		1 in 2
Notional permeability	P	0.1

* The rock density used was agreed with the Client, given the site availability

Using the waves provided, the resulting M₅₀ for the primary armour at the typical sections would suggest a rock size M₅₀=12kg. The calculation is included in Appendix B. This is of course a too small design rock size and although could be seen as illustrative of the sheltered location on the Tresco Sound, as described in Section 5.4.1, it reflects the fact that the long period wave component is not considered in the JBA waves and that extreme waves only were not provided at the design locations. If a conservative approach of considering the extreme water level and related depth limited wave is taken for the western beaches, a more reasonable M₅₀ of 2.4t is required, the top end of the 1 to 3 tonne grading. In line with the standardisation of rock armour elsewhere, the 1 to 3 tonne standard grading is selected. This rock should be placed in a minimum of two layers with the same layer thickness criterion and crest width as set out in Section 5.1.2.

The armour would be rough, angular rock and the quality of rock required will be specified in accordance with the European Armourstone Specification BS EN 13383 Parts 1 and 2, with a slope of 1V:2H.

5.6.2 Geotextile

A geotextile is also to be placed under the rock armour to help prevent migration of sand through the rock whilst ensuring permeability. The geotextile methodology is as set out Section 5.1.3. For 1 to 3 tonne armourstone grading, a HPS12 geotextile from Geofabrics has been selected. This is to be laid on the excavated profile ahead of rock placement.

5.6.3 Design section

The typical section and elevation for the Quay groyne works is included as Figure 5.9. It is expected that the Contractor develops final sections and details following the site topographic survey. Rocks are to be individually placed next to the quay structure and measures are to be taken to project the quay during construction.

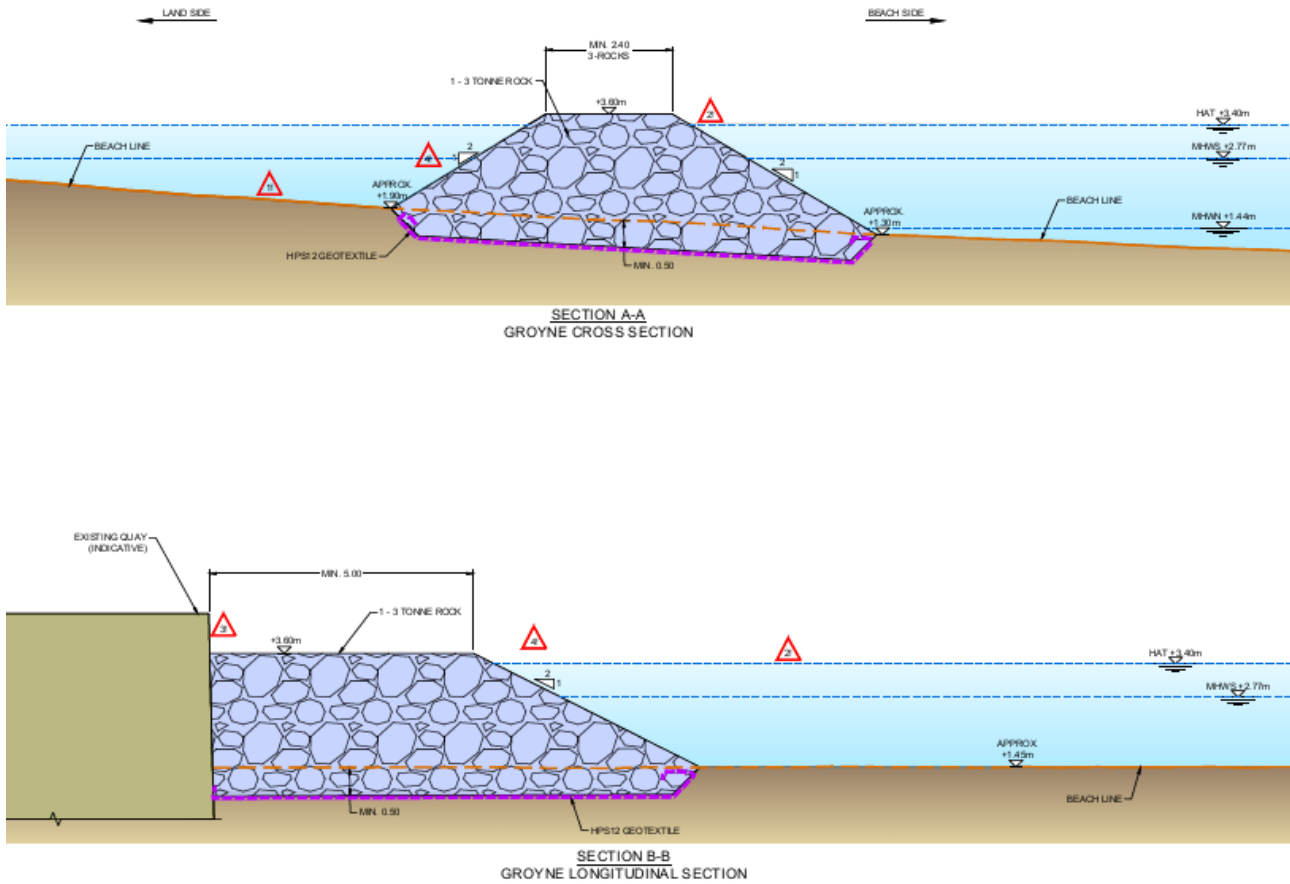

Figure 5.9: Site8b – The Quay groyne section and elevation

5.7 Site 9 – Green Bay – (DKR6499-210-D116; DKR6499-210-D370)

During the detailed design it was clarified from residents that although the boat yard area was the area to be protected, the overtopping volumes that had been previously observed were farther south than initially proposed, in the preliminary design report. On reviewing the LiDAR data, the proposed protection was shifted south from Ch 555 to Ch 625. The same concept is proposed with a geobag core to provide an impermeable protection against overtopping and an increased crest height. The alignment has been selected to work best with existing levels and minimise the footprint.

This extent is not currently classed as a defence asset by the Environment Agency, but once constructed, this should be included in the list of defence assets on the island and monitored. The proposed defence is immediately to the south of the Green Bay Embankment South asset.

5.7.1 Overtopping assessment

The overtopping methodology is as set out in Appendix A and Section 5.1 above. The waves at JBA Point 9 were transformed to the structure toe. The results and design crest height are presented in Table 5.12 with the minimum target increase of 0.25m identified in the OBC for the defence crest levels on the east of the island. The existing crest levels vary from 4.2 to 4.5m, and so a geobag crest level of 4.75m OD has been selected.

Table 5.12: Site 9 – Green Bay crest height design

Return Period (yr)	Wave Point	Wave at structure's toe		Water level (mOD)	Toe level (mOD)	Selected crest level (mOD)	Mean Overtopping (l/m/s)
		Hs (m)	Tp (s)				
45	9	0.8	5.6	3.55	1.3	5.3	3
1	9	0.6	4.7	3.58	1.3	5.3	0.3

5.7.2 Geobag stability

Geobags are proposed to provide a fixed crest level so that if the embankment is eroded in a storm, the geobags will remain in place and will continue to provide protection to the area behind from overtopping discharges.

The crest level of the geobags has been selected based on the approach described in Section 5.7.1 and the individual bags have been sized based on determining the stability of geotextile sand containers / structures using “Geosystems. Design rules and applications” by Bezuijen and Vastenburg and the work carried out by Oumeraci et al (2003, 2010) and Recio (2007).

The minimum size of geobag required is 1.5m x 0.75m x 0.3m, with calculations provided in Appendix B. These are to be filled and installed as per the suppliers requirements, and placed with two bags as a base and one above. Tencate Geotubes have been selected as an appropriate product, bags can be made to any size and GB600 material has been selected. The calculation is included in Appendix B and product information is included in Appendix F; refer to the specifications for further details.

5.7.3 Design section

A geomat has been included on the rear slope of the fill to help stabilise the slope whilst vegetation establishes itself, Robulon by Tencate has been selected as per the other sites.

A typical detail for the Site 9 works is included as Figure 5.10. This is a representative section taken from the LiDAR profiles. Typical sections for two locations are included in the sections drawing contained in Appendix C. Typical sections have been produced as detailed site topographic survey is not available. It is expected that the Contractor develops cross sections along the proposed frontage to confirm the sections along the full length.

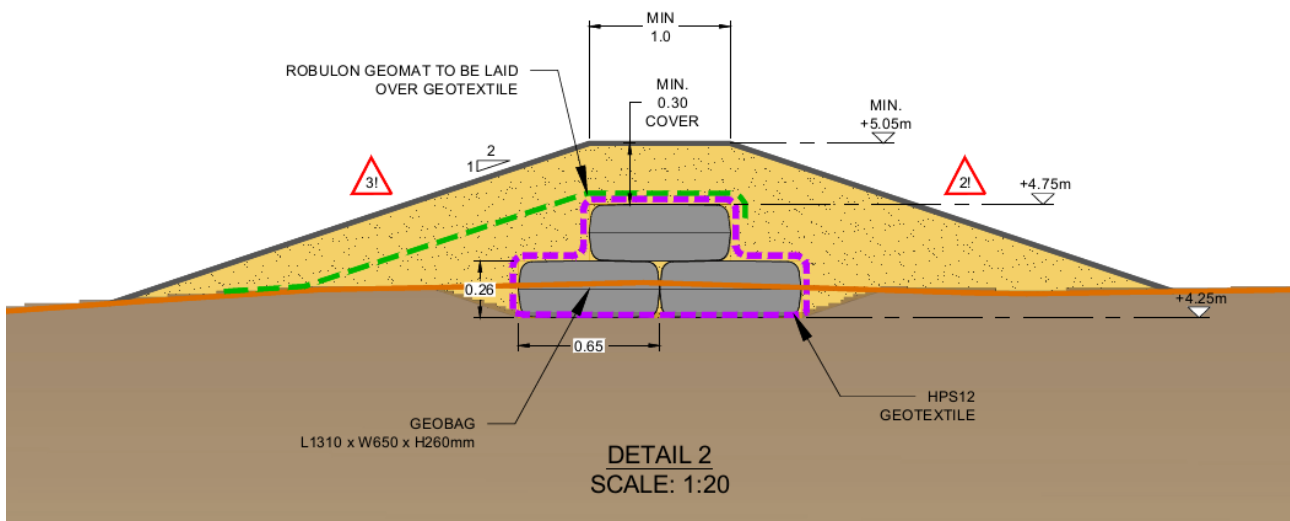

Figure 5.10: Site 9 – Green Bay typical profile detail

6 Materials

The material and general workmanship requirements are included in the design bases, Section A.8, and the project specifications.

7 Ground Investigation

A geotechnical survey scope of work and specification has been prepared in support of the design (DKR6499-RT008). It is important that this is undertaken ahead of construction to confirm the ground conditions and assumptions for material excavation and reuse as well as for the placement of additional sand and rock.

8 Health and Safety

It is HR Wallingford's intent, in all design works, to identify potential health and safety hazards and try to eliminate or mitigate the risk through the whole project life cycle from construction to operation and to demolition. This is in line with our role as Designer under the CDM 2015 regulations. The Council of the Isles of Scilly also have a role as the Client and are ultimately responsible for health and safety at the works; part of this is through the appointment of a competent Contractor who will manage the health and safety risks during construction.

A health and safety risk register has been completed, building from the general risk register included in the Preliminary Design reports. This identifies the key risks relating to the proposed works, rather than generic risks, and identifies where these are addressed in the design, if applicable, and who will manage the risk during the project life cycle. This relates to all three islands and is contained as Appendix D.

The key hazards for these works are associated with the island location and the access to the sites for the equipment and materials needed for the construction. Inter-island transport and roads networks are limited so beach landings may be utilised to access the sites for bringing in large and heavy items such as rock and precast concrete elements. Proper planning of the logistics for undertaking the works is important to ensure the appropriate equipment is used and monitoring of tides and weather ensures safe landing and offloading. It is likely that there may only be a short tidal window to enter the bays and so the barges may need to beach for a tidal cycle.

A preliminary review of the approaches to the island and the sites has been undertaken using Navionics marine charts (www.navionics.com). This is reproduced below and illustrates that the more sheltered approaches to the east of the island, where the main quays are located, will be tidally restricted and access to the eastern beaches appears more accessible but these western beaches are much more exposed to the Atlantic and navigation may be challenging for barges or landing craft. The Client has identified that all deliveries are to arrive through the Quay and adjacent beach (site 8b) on the west of the island and will provide island traffic routes as well as the location of the Contractor compound and laydown areas.



Figure 8.1: Bryher chart

Source: www.navionics.com

A services check has been undertaken for gas and electricity lines for Bryher and the plans received from the providers are included in Appendix E. South West Water were also contacted, but no details of the Bryher networks were available. No main service lines have been identified in the vicinity of the proposed works, but the Contractor is to carry out their own assessments. Contractor is also to consider access and temporary construction areas, prior to start of works on site, as the presence of unknown or old cabling and pipes is likely.

All sites should be checked with special care taken at Great Par North where an outfall, and buried pipe, exist and an unknown sewage pipe has been marked on previous drawings. These are indicated on the project drawings.

9 Bills of Quantity & cost estimates

9.1 Indirect costs

Bills of quantity and cost estimates have been produced for the construction elements and for the total cost estimate the indirect costs for managing and undertaking the works need to be added to the construction costs. These are added as % of the total construction costs and for large projects these % can be small but for smaller projects these will be higher.

The following additional indirect Contractor's costs are included in the construction cost estimates:

- Management and supervision;
- Contractors preliminaries including management and mobilisation/demobilisation costs;
- Contingency due to unforeseen design changes/site conditions.

9.1.1 Management and supervision

The engineering and project management is the input required support to the construction activities and as such is not directly involved with physical construction. This includes:

- Office management
- Construction management
- Design and documentation
- Procurement, inspections and surveys.

For complex civil engineering projects, the engineering design and project management, including logistics support can be as high as 25% of all construction costs for small complex works, but can be as low as 5% for large repetitive projects. For the proposed works, the design and logistics support is considered to cost approximately 18% of the total measured construction cost. Although the proposed works are technically not complex, the need for survey and site support has increased the assumed percentage.

Packaging up the works into large construction packages may bring some savings but each site is assumed as discrete at this stage.

9.1.2 Contractors preliminaries (Mob/Demob)

The cost of preliminary items for marine construction projects varies depending on:

- the type and number of plant items to be mobilised;
- whether modifications are required to plant items;
- how long it will take to mobilize and demobilize the equipment from its last project or its home base;
- ease of access to the site;
- security.

Preliminaries can be less than 10% for repetitive long duration projects but can be more than 30% for short duration specialist projects.

Considering the remote location of the Isles of Scilly, the mobilisation and demobilisation preliminaries in this location are considered to represent approximately 30% of all measured construction costs.

9.1.3 Contingency

Considering the location of the Isles of Scilly, and potential logistical challenges, a contingency of 30% on the costs estimates has been added to reflect the potential uncertainty with supply of materials and equipment.

This contingency also allows for additional works that may be required as part of any Environmental approvals. These have also not yet been received from the Client and these may impose conditions for the works that may require restorative or compensatory works not considered in these estimates.

9.2 Direct costs

The bills of quantity (BoQ) have been generated from the drawings created for each site. Volumes and areas have been taken off from the AutoCAD drawings to populate the BoQ. The key assumptions for the quantities and the cost estimates are listed here.

Quantities

- Ground levels are based on existing Lidar data at a representative section for each beach and proposed intervention
- Bulking factors included for bulk rather than placed material
- Geotextile and geogrid areas include 20% allowance for overlap, surfacing geomats include a 10% allowance.

Rates

- The rates used are from a combination of sources:
 - An inhouse database for similar marine projects
 - Similar recent UK project costs
 - Specific rates have been requested from suppliers for this project
 - SPONS (2020) construction database – These are benchmarked for larger scale works and so a 25% uplift has been applied to all SPONS rates.

9.3 Island summaries

Detailed bills of quantity for each site and island are included in Appendix E. The costs are summarised in the following tables. Note these do not include signage and fencing to manage access onto the beaches nor any other soft measures not included in the drawings.

Table 9.1: Bryher cost summary

Site	Cost (GBP)
1 – Greatpar South	625,648
2/3b – Great Porth	517,036
3 – Stinking Porth	308,810
4 – Great Popplestone	273,055
5 – Kitchen Porth	66,098
8b – Quay	40,601
9 – North Green Bay	86,554
TOTAL	1,917,803

10 Environment and Constructability

10.1 General logistics

The accessibility of the Isles of Scilly means that there is not a regular and simple supply chain for delivery of materials and equipment hire. It has been the intent of the design to detail works that do not require large construction plant and can be constructed by standard axle width equipment such as JCB back hoe and small excavators that can use existing access tracks and routes to each location.

Bryher, as with each of the Isles of Scilly, is very exposed to waves, swell and winds so sea conditions will need to be carefully monitored to ensure safe cargo arrival and offloading operations. The JBA (2019) wave analysis report does not include operational conditions so the Contractor should do their own assessment for seasonal extreme wave conditions, but only for information on a 0.22 year return period event, i.e. 5 times per year storm, give an estimated Hs of 0.5m.

The Client will identify the site compound and access routes that the Contractor will have to take though the provisional compound and routing is shown in Figure 10.1. These boundaries are subject to review and possible changes and are to be agreed by the Client prior to starting any works. Two areas to note are the access to the Quay and Green Bay are via the beach, so tides need monitoring and there is a very sharp bend to the west of the Church Quay offloading point and the contractor should confirm routes as appropriate for the plant required for the works.



Figure 10.1: Bryher site boundaries, access routes and access hazards

Source: Based on information provided by the Council of the Isles of Scilly

There are likely to be seasonal constraints due to the tourist season and bird nesting, and therefore work during winter months is likely to be required. CDM (2015) regulations require that the health and safety of the workers as well as the public is to be fully considered in the logistical and construction approach. The scheduling of construction during the winter months requires that bad weather is to be considered in all plans.

10.2 Plant & labour

The accessibility of the Isles of Scilly means that there is not a regular and simple supply chain for delivery of materials and hire of equipment. It has been the intent of the design to detail works that do not require large construction plant and can be constructed by standard axle width equipment such as JCB back hoe and small excavators that can use existing access tracks and routes to each location, though the 1-3T rock and concrete at Great Porth North may require larger equipment for delivery and placement. It is assumed that the concrete is precast and placed without need for concrete works on site.

All construction works will be from the back of the beaches, limiting the need for plant to be placed in tidal areas. A long arm excavator with grab with the required reach will be needed for the armour placement. It is assumed that all materials will arrive through the existing quay and planning of the logistics for the works is essential as the allocated site compound is limited in area. This is to house contractor facilities as well as store plant and materials.

Rock placement is skilled labour as rocks need to be individually selected and placed, but much of the other general works can be carried out by workers from the Isles of Scilly where possible to support the local economy.

10.3 Materials

One of the main challenges to the works is the supply of materials. To reduce the reliance on importing, the intent is to reuse rock and fill materials where possible. On Bryher there is an excess of excavated material across the sites, only at Site 9 is there a deficit of fill material and some of the excess generated from the other sites will need to be transferred here for these works.

Rock will need to be imported, a proportion of existing rock on the beaches can be reused but new material will need to be imported to the island. It is assumed that this will be sourced from Cornwall and shipped by barge directly to the Island. The Contractor should refer to the relevant environmental documentation for information on where plant and materials can be brought to the island. The Contractor should combine deliveries into these barges wherever possible to reduce the number of barges.

10.4 Environment

The Isles of Scilly are internationally significant habitats for a variety of sensitive habitats and the Contractor is to refer to the environmental documentation to confirm designations and any specific requirements for the works or access to the works.

The Isles of Scilly is also an Area of Outstanding Natural Beauty (AONB), a conservation area and a heritage coast. An environmental impact assessment (EIA) is being carried out by others and the requirements identified from this need to be incorporated into the construction methodology. Although it is understood that the works are not themselves located in specific environmentally designated areas (such as site of special scientific interest (SSSI) or RAMSAR) the methodology needs to consider access, scheduling of works, noise and any other aspects identified in the EIA.

11 References

1. Bryher preliminary design report, DKR6499-RT003, HR Wallingford, 2021.
2. Goda, Y., 2000. Random Seas and Design of Maritime Structures, Advanced Series on Ocean Engineering, Vol. 15, World Scientific.
3. Sutherland, 2006. Understanding the lowering of beaches in front of coastal defence structures, Phase 2, Joint Defra/EA Flood and Coastal Erosion.
4. Powell, K.A, Lowe, J. P. (1994) The scouring of sediments at the toe of seawalls. In: Proceedings of the Hornafjordur International Coastal Symposium, Iceland - June 20-24.

Appendices

A Design Bases

A.1 Design life

The design life for the coastal scheme is 25 years.

A.2 Coordinate system

National Grid for plane coordinates.

A.3 Vertical datum

All levels are shown in m OD.

A.4 Data

A.4.1 Topographic and Bathymetric data

The following topographic data was used:

- LiDAR downloaded from: <https://environment.data.gov.uk/DefraDataDownload/?Mode=survey>:
 - Digital Surface Model (DSM) - this LiDAR data type was chosen for consistency and better understanding when displaying data in Excel plots. Generally a DTM would be preferable but in this case, not available for all years of interest.
 - Years used: 2011, 2014, 2018 and 2020.

During the analysis of the LiDAR data, 'discrepancies' were apparent between surveys regarding elevation ('z' values). To address this issue, an additional elevation check was carried out using profile data from the Channel Coastal Observatory (CCO). The CCO data provided topographical coastline profiles using the same vertical datum (m ODN) as the LiDAR, therefore a local comparison could be made against the LiDAR datasets. This allowed an informed decision to be made regarding what was a 'realistic' elevation for a particular match of survey year. Following on from this, it was decided that the 2011 LiDAR (earliest year) values should be used as the baseline to adjust the other LiDAR survey to, thus making all the datasets nominally comparable. Hard point elevation values (roads surfaces, concrete slipways) were extracted from the same positions in all LiDAR datasets in order to work out an average difference (adjustment) between a baseline year and the other years of interest. The average adjustment values were applied to the 2014/18/20 datasets so these could be brought in line with the 2011 baseline LiDAR.

A.5 Water Levels

A.5.1 Sea and tidal levels

Table A.1: Tide Tables

Level	Elevation (m CD) -	Elevation (m OD) -
MHWS	5.68	2.77
MHWN	4.35	1.44
MLWN	2.04	-0.87
MLWS	0.73	-2.18
LAT	0.09	-2.82

Source: HR Wallingford

A.5.2 Extreme water levels

Extreme sea levels were based on predictions published in the Environment Agency's Coastal Flood Boundaries report, Environment Agency (2018). These were updated to the present (2021) to account for likely rises on sea levels since 2017, the base date for these levels, University of Colorado (2021), and estimated changes in land levels since this date, Bradley *et. al.* (2008).

Site CFB Chainage	Extreme still water level for the year 2017 per AEP (mODK)										
	50%	20%	10%	5%	4%	3.33%	2%	1.33%	1%	0.5%	0.1%
ESL 0	3.51	3.59	3.64	3.69	3.71	3.72	3.75	3.78	3.80	3.84	3.95

Figure A.1: Extreme sea level data

Source: JBA (2019)

A.5.3 Sea level rise

The JBA study (ref. 3) included the appropriate guidance from the National Planning Policy Framework (NPPF) on sea level rise at the time (https://assets.publishing.service.gov.uk/government/uploads/system/uploads/attachment_data/file/6000/2115548.pdf). This forecast a 100 year sea level rise of 1.037m.

The advice on sea level rise assumptions has since been revised and the current Environment Agency guidance is set out here; <https://www.gov.uk/guidance/flood-risk-assessments-climate-change-allowances>.

The detailed design has not included any modelling, so the wave and water level combinations provided by JBA (ref 3) are taken as the design inputs. Where consideration of sea level rise separate to these combinations is made, the current guidance has been used. For the Upper End allowances in the South West region, this gives an allowance of 0.223m for a 25yr design life and 1.398m for a 100 year design life from 2021.

A.6 Waves

The RFP did not require wave modelling and instructed the tenderers to extract the required input data from "The Isles of Scilly Coastal Flood Modelling" (JBA for the EA, 2019). A preliminary review of this document showed that the report did not provide suitable wave data for detailed design. More information on extreme waves and water levels data were required. The Client requested the data, in electronic copy, from the Environment Agency at the start of the project.

The EA provided a first set of data, which was considered insufficient. A further more extensive set of data

was subsequently provided. This was reviewed and design wave conditions were extracted.

As instructed by the Client, HR Wallingford have utilised the data provided from the above mentioned study. HR Wallingford has duly reviewed the information provided and confirms that they appear reasonable. However, without access to the raw data, and repeating the full analysis, we note that HR Wallingford are unable to take responsibility for any existing data quality and quantity provided by others.

The data supplied to HR Wallingford from the JBA modelling study consists of a sub-set of 10,000 years' of modelled extreme conditions, which has been set-up for extreme overtopping conditions. This sub-set of data contains the combinations of wave and sea level parameters that give the largest overtopping rate, although not necessarily the largest wave heights. However, the method adopted to generate these data was developed by HR Wallingford (see for example Gouldby et. al., 2017), and it is considered that a reliable estimate of the extreme wave heights at the site(s) could be determined from the data provided.

Two sets of data were provided:

- Defended
- Defended NPPF 2117.

Where NPPF stands for “National Planning Policy Framework”.

It is assumed that:

- “Defended” is the current day (2017) estimate of wave heights and overtopping rates with existing sea defences.
- “Defended NPPF 2117” is the 2117 estimate of wave heights and overtopping rates which includes a 10% increase in offshore wind speed and wave heights, though no adjustment seems to be made to the wave period to maintain the input wave steepness. Sea level rise from 2017 to 2117 is given as 1.037m. This seems to be consistent with guidance given for the higher central allowance for sea level rise as currently given in this link:

<https://www.gov.uk/guidance/flood-risk-assessments-climate-change-allowances#sea-level-allowances>

The information for the relevant sites at Bryher were extracted from these datasets. As part of the present study, a SLR allowance has been included in the water level to update the data to present day water levels (@2021) and to calculate water levels in 2046 (25 years life).

A.6.1 Extreme wave heights and water levels

The design return period for Bryher has been confirmed by the Client as a 1 in 45 year return period. Based on the review of the data as described above and through interpolation between the 2017 and 2117 defended epochs, the following criteria have been selected for the design wave conditions and associated water levels at each of the sites considering the 25 year design life, for overtopping calculation only.

Table A.2: Design waves and water levels (joint probability)

Site	Hs (m)	Tp (s)	Water Level
1	1.1	8.5	3.2
2	0.9	10.9	3.7
3b	0.7	10.0	3.9
3	1.2	10.2	3.8
4	0.8	10.4	3.4
5	1.5	11.3	3.6
8b	0.4	8.1	4.0
9	0.8	5.6	3.5

Source: HR Wallingford

Extreme wave heights with 1 in 45 return period have been calculated as depth limited waves, using the extreme water levels provided, see Section A.5.2 above, including 25 years sea level rise. The depth limited wave was calculated at the -1m OD bed level and then propagated using Goda's methodology to the toe of each new structure. A $T_p=10s$ was assumed for all sites, which compare well with most of the waves above.

The allowance for sea level rise has been taken from the EA's State of the Nation Report that

Given the location of Sites 5 to 9 the results from the methodology above were compared with the combinations in Table A.2 and engineering judgment was used to select the appropriate design conditions.

A.7 Overtopping assessment

A wave overtopping study was carried out as part of the JBA(2019) study for the EA. This study provided as output the flood extent and recommendations for the increase in crest elevation required along the coastal frontages. In addition, indications were given for flood alerts related to water levels and overtopping discharges.

As part of the present study, overtopping calculations are undertaken to assess the stability of the coastal/flood protection. No flood modelling is performed for the selected options, since this is outside the present scope of work.

The recommendations given in Ref. 2 and Ref.3, based on flood modelling, are considered as part of the assessment. Wave overtopping at the revetments is assessed using the empirical formulations reported in the EurOtop II (2016) manual.

A.8 Materials

A.8.1 Quarry rock properties

A quarry rock density of 2650 kg/m^3 is preferable, though given the availability of rock on site and following discussions with the Client a density of 2600 kg/m^3 is assumed in the design of the rock revetment. This is the lower end of typical values for granite, so is a conservative value to use.

A.8.2 Concrete properties

A minimum concrete density of 2400 kg/m^3 is assumed for concrete, for any flood or wave wall incorporated in the design.

A.8.3 Dune/Ridge recharge material

It is assumed that sand and recharge material to match existing ground can be locally sourced from the island, where it needs to be imported the material is to be clean, free from debris or plant matter and graded to match the existing material.

A.8.4 Geotextile properties

The geotextiles to be used should be designed to meet the following criteria:

- A permeability criterion to ensure the geotextile is permeable enough to allow liquid to pass through relatively unhindered;
- A retention criterion to ensure the geotextile openings are small enough to prevent excessive migration of soil particles ("piping");

- An anti-clogging criterion to ensure the geotextile is porous enough so when soil particles become entrapped in or on the geotextile its permeability will not be adversely affected;
- A survivability criterion to ensure the geotextile survives installation; and,
- A durability criterion to ensure the geotextile is durable enough to withstand the effects of chemicals, UV light and abrasive conditions for the life of the project.

A.9 Design criteria

A.9.1 Ultimate limit states

Rock armour

For stability, a return period event of 1:200 year (0.5% probability per annum) is used for the preliminary design. The target damage level at this return period is selected as per the Rock Manual guidelines (CIRIA/CUR/CETMEF (2007)):

- Start of Damage: $S_d = 2$ – corresponds to “no damage” with approximately less than 5% armour rock displacement.

Overtopping

Guidance on methodologies and maximum allowable overtopping rates along the frontage will follow the recommendations in EurOtop II (2018), though consideration will also be given to acceptable flooding and acceptable damage following the conclusions and recommendations provided in Ref.2 and Ref. 3.

The crest level/configuration of the flood protection will be designed in such a way to limit mean wave overtopping and minimize risk of flooding and damage to the banks. Overtopping discharges obtained along the frontage will be reviewed considering the stability of the structures.

Based on extensive research on the resistance of grass covered slopes under overtopping events, EurOtop II (2018) provides the following suggestions:

- A good closed grass cover without open holes is very resilient to wave overtopping for wave heights $H_{m0} < 3\text{m}$.
- A badly maintained grass cover with open holes and a lot of moss may fail well below $q < 5\text{ l/s/m}$.

These limits are summarised in Table A.3.

Table A.3: Design return periods for the quay walls and the maximum allowable overtopping

Hazard type and reason	Mean discharge q (l/s per m)
Grass covered crest and landward slope; maintained and closed grass cover; $H_{m0} = 1 - 3\text{ m}$	5
Grass covered crest and landward slope; not maintained grass cover, open spots, moss, bare patches; $H_{m0} = 0.5 - 3\text{ m}$	0.1
Grass covered crest and landward slope; $H_{m0} < 1\text{ m}$	5-10

Source: EurOtop II (2018)

Geotextile sand containers

It is envisaged that geotextile tubes/containers, referred to as geocontainers in this report, will be used as part of the proposed material. Geotextile sand containers are a low cost, soft and reversible solution for a cost effective shore protection, and have a history of more than 50 years in hydraulic and marine applications.

Coastal structures built with geotextile sand containers are obtained by substituting rocks or concrete units with containers made of geotextile and filled with locally available sand.

The hydraulic processes affecting the stability of geotextile sand containers / structures will be assessed using Geosystems. Design rules and applications” by Bezuijen and Vastenburg and the work carried out by Oumeraci et al (2003, 2010) and Recio (2007).

A.9.2 Serviceability limit states

Sea defence overtopping conditions with a 1 in 1 year joint probability return period will be used as the SLS design criterion. The sea defence will be designed in such a way that it will limit wave overtopping over the public footpath with a target maximum not to exceed $q = 1$ l/s/m in order to not cause danger to pedestrians who are assumed to be aware of the weather conditions, see Figure A.2 extract from EurOtop (2018). The limit applicable for all the sites refers to $H_{m0} < 2$ m.

No damage criteria are necessary for this serviceability limit state.

Hazard type and reason	Mean discharge q (l/s per m)	Max volume V_{max} (l per m)
People at structures with possible violent overtopping, mostly vertical structures	No access for any predicted overtopping	No access for any predicted overtopping
People at seawall / dike crest. Clear view of the sea.		
$H_{m0} = 3$ m	0.3	600
$H_{m0} = 2$ m	1	600
$H_{m0} = 1$ m	10-20	600
$H_{m0} < 0.5$ m	No limit	No limit
Cars on seawall / dike crest, or railway close behind crest		
$H_{m0} = 3$ m	<5	2000
$H_{m0} = 2$ m	10-20	2000
$H_{m0} = 1$ m	<75	2000
Highways and roads, fast traffic	Close before debris in spray becomes dangerous	Close before debris in spray becomes dangerous

Figure A.2: Limits for overtopping for people and vehicles

Source: *Extracted from EurOtop II (2018) Table 3.3*

A.10 Code and standards

The design of the coastal works has been carried out in accordance with the codes, standards and guidance documents as listed below:

- British Standards, BS6349 suite, Maritime Structures;
- BS EN 1991-1-1:2002. Eurocode 1: Actions on structures - Part 1-1: General actions. BSI;
- BS EN 1992-1-1 :2004. Eurocode 2: Design of Concrete Structures – Part 1-1: General rules. BSI;
- BS EN 1997-1:2004 Eurocode 7: Geotechnical design - Part 1: General rules. BSI;
- BS EN 13383 Parts 1 and 2 European Armourstone Specification;
- BS6349-1-2:2016: Maritime Works General. Code of Practice for Assessment of Actions.

In addition to the standards above, the following international guides for good practice have also been adopted:

- CIRIA; CUR; CETMEF, (2007). The Rock Manual. The Use of Rock in Hydraulic Engineering; (2nd Edition), London;
- CIRIA, (2010). Beach management manual. (2nd Edition), London. PUB C685;
- CIRIA, (2020). Groynes in coastal engineering – Guide to design, monitoring and maintenance of narrow footprint groynes, London;
- EurOTop II (2018).

B Calculations

COVER SHEET



Project	Isles of Scilly Climate Adaptation	Calc no.	-	Project Engineer	MLO
Contract	DKR6499	Filename ref	-	Designer	
Section	Bryher	Job No.	-	Department	Engineering
Subject	Rock size design – Bryher				

	Total Sheets	Mathcad Made by	Date	Cal Made by	Date	Checked by	Date		
ORIGINAL		MJJ	25 / 10 / 11	MLO	06/07/2021				
REV 0				MLO	24/06/2022	AGC	29/06/2022		
REV 1									
REV 2									
REV 3									
REV 4									
Superseded by Calculation no.					Date				

Objective of Calculation:

Rock Sizing

Description of Calculation:

Van der Meer rock armour calculation marginally overtopped structures, based on: The Rock Manual (2007), p567

Van der Meer rock armour calculation emergent structures, based on: The Rock Manual (2007), p600

INPUT

Wave conditions used are:

Waves at the toe provided by JBA

Waves propagated to the toe of the structures using Goda (2010)

A 12 hours storm has been considered

Nominal Permeability P considered to be $P=0.1$.

It is expected that some reshaping may occur even if a $S_d=2$ has been used, due to potential settlement of the toe following major storms.

TO BE READ IN CONJUNCTION WITH INPUT FILE

...\\dkr6499\3_technical\Detailed_Design(Stage4-RIBA)\1_Bryher\1 - Greatpar South\ 1_ Van_der_Meer_multi_calculation_input.xlsx

INPUT DATA

Input data can be directly entered into table below or imported from an Excel spreadsheet

data :=

	0	1	2	3	4	5	6	
0	"ID"	" Hs max(m)"	"H2% (m)"	"Tm (s)"	"Tme (s)"	"Nw"	"P"	
1	"1_Case_1"	1.76	2.363	8.2	9.091	5.268·10 ³	0.1	
2	"2_Case_1"	1.5	2.028	8.2	9.091	5.268·10 ³	0.1	
3	"3b_Case_1"	1.5	2.028	8.2	9.091	5.268·10 ³	0.1	
4	"3_Case_1"	1.44	1.952	8.2	9.091	5.268·10 ³	0.1	
5	"4_Case_1"	1.05	1.461	8.2	9.091	5.268·10 ³	0.1	
6	"5_Case_1"	0.8	1.174	8.2	9.091	5.268·10 ³	0.1	
7	"8b_Case_1"	0.4	0.5	8.2	9.091	5.268·10 ³	0.1	
8	1	1	1	1	1	1	1	
9	1	1	1	1	1	1	1	
10	1	1	1	1	1	1	1	
11	1	1	1	1	1	1	1	
12	1	1	1	1	1	1	1	
13	1	1	1	1	1	1	1	
14	1	1	1	1	1	1	1	
15	1	1	1	1	1	1	1	
16	1	1	1	1	1	1	1	
17	1	1	1	1	1	1	1	
18	1	1	1	1	1	1	1	
19	1	1	1	1	1	1	1	
20	1	1	1	1	1	1	1	
21	1	1	1	1	1	1	1	
22	1	1	1	1	1	1	1	
23	1	1	1	1	1	1	1	
24	1	1	1	1	1	1	1	
25	1	1	1	1	1	1	1	
26	1	1	1	1	1	1	1	
27	1	1	1	1	1	1	1	
28	1	1	1	1	1	1	1	
29	1	1	1	1	1	1	1	
30	1	1	1	1	1	1	1	
31	1	1	1	1	1	1	1	

To calculate H2% use "H2%_calculation_2008.xls"

Peak wave period T_p is estimated using $T_m/0.82$

Energy wave period (T_{me}) can be estimated using $T_p/1.1$

h_t is the depth of water at the toe of the structure



	data _{1,0}	data _{1,1}	data _{1,2}	data _{1,3}	data _{1,4}	data _{1,5}	data _{1,6}	data _{1,7}	data _{1,8}	data _{1,9}	data _{1,10}	
	data _{2,0}	data _{2,1}	data _{2,2}	data _{2,3}	data _{2,4}	data _{2,5}	data _{2,6}	data _{2,7}	data _{2,8}	data _{2,9}	data _{2,10}	
	data _{3,0}	data _{3,1}	data _{3,2}	data _{3,3}	data _{3,4}	data _{3,5}	data _{3,6}	data _{3,7}	data _{3,8}	data _{3,9}	data _{3,10}	
	data _{4,0}	data _{4,1}	data _{4,2}	data _{4,3}	data _{4,4}	data _{4,5}	data _{4,6}	data _{4,7}	data _{4,8}	data _{4,9}	data _{4,10}	
	data _{5,0}	data _{5,1}	data _{5,2}	data _{5,3}	data _{5,4}	data _{5,5}	data _{5,6}	data _{5,7}	data _{5,8}	data _{5,9}	data _{5,10}	
	data _{6,0}	data _{6,1}	data _{6,2}	data _{6,3}	data _{6,4}	data _{6,5}	data _{6,6}	data _{6,7}	data _{6,8}	data _{6,9}	data _{6,10}	
	data _{7,0}	data _{7,1}	data _{7,2}	data _{7,3}	data _{7,4}	data _{7,5}	data _{7,6}	data _{7,7}	data _{7,8}	data _{7,9}	data _{7,10}	
	data _{8,0}	data _{8,1}	data _{8,2}	data _{8,3}	data _{8,4}	data _{8,5}	data _{8,6}	data _{8,7}	data _{8,8}	data _{8,9}	data _{8,10}	
	data _{9,0}	data _{9,1}	data _{9,2}	data _{9,3}	data _{9,4}	data _{9,5}	data _{9,6}	data _{9,7}	data _{9,8}	data _{9,9}	data _{9,10}	
	data _{10,0}	data _{10,1}	data _{10,2}	data _{10,3}	data _{10,4}	data _{10,5}	data _{10,6}	data _{10,7}	data _{10,8}	data _{10,9}	data _{10,10}	
	data _{11,0}	data _{11,1}	data _{11,2}	data _{11,3}	data _{11,4}	data _{11,5}	data _{11,6}	data _{11,7}	data _{11,8}	data _{11,9}	data _{11,10}	
	data _{12,0}	data _{12,1}	data _{12,2}	data _{12,3}	data _{12,4}	data _{12,5}	data _{12,6}	data _{12,7}	data _{12,8}	data _{12,9}	data _{12,10}	
	data _{13,0}	data _{13,1}	data _{13,2}	data _{13,3}	data _{13,4}	data _{13,5}	data _{13,6}	data _{13,7}	data _{13,8}	data _{13,9}	data _{13,10}	
	data _{14,0}	data _{14,1}	data _{14,2}	data _{14,3}	data _{14,4}	data _{14,5}	data _{14,6}	data _{14,7}	data _{14,8}	data _{14,9}	data _{14,10}	
	data _{15,0}	data _{15,1}	data _{15,2}	data _{15,3}	data _{15,4}	data _{15,5}	data _{15,6}	data _{15,7}	data _{15,8}	data _{15,9}	data _{15,10}	
input :=	data _{16,0}	data _{16,1}	data _{16,2}	data _{16,3}	data _{16,4}	data _{16,5}	data _{16,6}	data _{16,7}	data _{16,8}	data _{16,9}	data _{16,10}	*
	data _{17,0}	data _{17,1}	data _{17,2}	data _{17,3}	data _{17,4}	data _{17,5}	data _{17,6}	data _{17,7}	data _{17,8}	data _{17,9}	data _{17,10}	
	data _{18,0}	data _{18,1}	data _{18,2}	data _{18,3}	data _{18,4}	data _{18,5}	data _{18,6}	data _{18,7}	data _{18,8}	data _{18,9}	data _{18,10}	
	data _{19,0}	data _{19,1}	data _{19,2}	data _{19,3}	data _{19,4}	data _{19,5}	data _{19,6}	data _{19,7}	data _{19,8}	data _{19,9}	data _{19,10}	
	data _{20,0}	data _{20,1}	data _{20,2}	data _{20,3}	data _{20,4}	data _{20,5}	data _{20,6}	data _{20,7}	data _{20,8}	data _{20,9}	data _{20,10}	
	data _{21,0}	data _{21,1}	data _{21,2}	data _{21,3}	data _{21,4}	data _{21,5}	data _{21,6}	data _{21,7}	data _{21,8}	data _{21,9}	data _{21,10}	
	data _{22,0}	data _{22,1}	data _{22,2}	data _{22,3}	data _{22,4}	data _{22,5}	data _{22,6}	data _{22,7}	data _{22,8}	data _{22,9}	data _{22,10}	
	data _{23,0}	data _{23,1}	data _{23,2}	data _{23,3}	data _{23,4}	data _{23,5}	data _{23,6}	data _{23,7}	data _{23,8}	data _{23,9}	data _{23,10}	
	data _{24,0}	data _{24,1}	data _{24,2}	data _{24,3}	data _{24,4}	data _{24,5}	data _{24,6}	data _{24,7}	data _{24,8}	data _{24,9}	data _{24,10}	
	data _{25,0}	data _{25,1}	data _{25,2}	data _{25,3}	data _{25,4}	data _{25,5}	data _{25,6}	data _{25,7}	data _{25,8}	data _{25,9}	data _{25,10}	
	data _{26,0}	data _{26,1}	data _{26,2}	data _{26,3}	data _{26,4}	data _{26,5}	data _{26,6}	data _{26,7}	data _{26,8}	data _{26,9}	data _{26,10}	
	data _{27,0}	data _{27,1}	data _{27,2}	data _{27,3}	data _{27,4}	data _{27,5}	data _{27,6}	data _{27,7}	data _{27,8}	data _{27,9}	data _{27,10}	
	data _{28,0}	data _{28,1}	data _{28,2}	data _{28,3}	data _{28,4}	data _{28,5}	data _{28,6}	data _{28,7}	data _{28,8}	data _{28,9}	data _{28,10}	
	data _{29,0}	data _{29,1}	data _{29,2}	data _{29,3}	data _{29,4}	data _{29,5}	data _{29,6}	data _{29,7}	data _{29,8}	data _{29,9}	data _{29,10}	
	data _{30,0}	data _{30,1}	data _{30,2}	data _{30,3}	data _{30,4}	data _{30,5}	data _{30,6}	data _{30,7}	data _{30,8}	data _{30,9}	data _{30,10}	
	data _{31,0}	data _{31,1}	data _{31,2}	data _{31,3}	data _{31,4}	data _{31,5}	data _{31,6}	data _{31,7}	data _{31,8}	data _{31,9}	data _{31,10}	

$$H_s := \text{input}^{\langle 1 \rangle} \cdot m \quad H_{2\%} := \text{input}^{\langle 2 \rangle} \cdot m \quad T_m := \text{input}^{\langle 3 \rangle} \cdot s \quad T_{m_e} := \text{input}^{\langle 4 \rangle} \cdot s \quad N_w := \text{input}^{\langle 5 \rangle} \quad P := \text{input}^{\langle 6 \rangle}$$

$S_d := \text{input}^{(7)}$ slope := $\text{input}^{(8)}$ $R_c := \text{input}^{(9)} \cdot \text{m}$ $ht := \text{input}^{(10)} \cdot \text{m}$



Structure and material properties

$$r := 2.60 \frac{\text{tonne}}{\text{m}^3} \quad \text{Rock density}$$

$$w := 1.025 \frac{\text{tonne}}{\text{m}^3} \quad \text{Water density}$$

$$:= \left(\frac{r}{w} \right) - 1 = 1.54 \quad \text{Buoyant density}$$

CALCULATIONS FOR DEEP WATER MARGINALLY OVERTOPPED STRUCTURES

$$s_m := \frac{2 \cdot H_s}{g \cdot T_m^2} \quad \text{Wave steepness}$$

$$s_{op} := \frac{2 \cdot H_s}{g \cdot \left(\frac{T_m}{0.82} \right)^2} \quad \text{Wave steepness in deep water}$$

Structure slope; slope = cot α

$$:= \frac{1}{\tan(\alpha)}$$

Plunging - surging waves (Deep water)

Expand table if required:

$$m := \frac{\text{slope}^{-1}}{\sqrt{s_m}}$$

Iribarren number

	0
0	2.57
1	3.35
2	...

The transition from plunging to surging waves occurs when the Iribarren number is above a critical value

Transition value for Iribarren number: $m_{cr} := \text{for } i \in 0.. \text{last}(\text{input} \langle 1 \rangle)$

Expand table if required:

	0
0	2.55
1	2.97
2	...

$$m_{cr_i} \leftarrow \left[6.2 \cdot (P_i)^{0.31} \cdot \left[\left(\tan(\alpha)_i \right)^{\frac{1}{2}} \right] \right]^{\frac{1}{P_i + 0.5}}$$

Armour layer stone size (Deep Water)

$D_{n50pl_D} := \text{for } i \in 0.. \text{last}(\text{input} \langle 1 \rangle)$

Stone size for plunging waves:

$$D_{n50pl_D_i} \leftarrow \frac{H_{s_i}}{6.2 \cdot (P_i)^{0.18} \cdot \left(\frac{S_{d_i}}{\sqrt{N_{w_i}}} \right)^{0.2} \cdot (m_i)^{-0.5}}$$

Stone size for surging waves:

$$D_{n50su_D} := \text{for } i \in 0.. \text{last}(\text{input}^{(1)})$$

$$D_{n50su_D_i} \leftarrow \frac{H_{s_i}}{1.0 \cdot (P_i)^{-0.13} \cdot \left(\frac{S_{d_i}}{\sqrt{N_{w_i}}} \right)^{0.2} \cdot (\text{slope}_i)^{0.5} (m_i)^{P_i}}$$

$$\square D_{n50_D} := \text{for } i \in 0.. \text{last}(\text{input}^{(3)}) \left\{ \begin{array}{l} D_{n50_D_i} \leftarrow D_{n50pl_D_i} \text{ if } m_i < mcr_i \\ D_{n50_D_i} \leftarrow D_{n50su_D_i} \text{ otherwise} \end{array} \right.$$

$$\text{check_d} := \text{for } i \in 0.. \text{last}(\text{input}^{(3)}) \left\{ \begin{array}{l} \text{check_d}_i \leftarrow \text{"plunging waves"} \text{ if } m_i < mcr_i \\ \text{check_d}_i \leftarrow \text{"surging waves"} \text{ otherwise} \end{array} \right.$$

ARMOUR LAYER RESULTS DEEP WATER MARGINALLY OVERTOPPED STRUCTURES

	0		0		0		
	"surging waves"		0 0.915	$M_{50_D} := r D_{n50_D}^3$	0 1990		
	"surging waves"		1 0.832		1 1497		
	"surging waves"		2 0.832		2 1497		
	"surging waves"		3 0.871		3 1720		
	"surging waves"		4 0.532		4 391		
	"surging waves"		5 0.47		5 270		
	"surging waves"		6 0.227		6 30		
	"plunging waves"		7 0.117		7 4		
	"plunging waves"		8 0.117		8 4		
	"plunging waves"		9 0.117		9 4		
	"plunging waves"		10 0.117		10 4		
	"plunging waves"		11 0.117		11 4		
	"plunging waves"		12 0.117		12 4		
	"plunging waves"		13 0.117		13 4		
check_d =	"plunging waves"	$D_{n50_D} =$	14 0.117		m	$M_{50_D} =$	14 4
	"plunging waves"		15 0.117			kg	15 4
	"plunging waves"		16 0.117				16 4
	"plunging waves"		17 0.117				17 4
	"plunging waves"		18 0.117				18 4
	"plunging waves"		19 0.117				19 4
	"plunging waves"		20 0.117				20 4
	"plunging waves"		21 0.117				21 4
	"plunging waves"		22 0.117				22 4
	"plunging waves"		23 0.117				23 4
	"plunging waves"		24 0.117				24 4
	"plunging waves"		25 0.117				25 4
	"plunging waves"		26 0.117				26 4
	"plunging waves"		27 0.117				27 4
	"plunging waves"		28 0.117				28 4
	"plunging waves"		29 0.117				29 4
	"plunging waves"		30 0.117			30 4	

CALCULATIONS FOR SHALLOW WATER marginally OVERTOPPED STRUCTURES

Plunging - surging waves (Shallow water)

$$s := \frac{\tan(\)}{\sqrt{\frac{2 \cdot H_s}{g T_{m_e}^2}}}$$

surf similarity parameter

Expand table if required:

	0
0	2.854
1	3.709
2	3.709
3	...

The transition from plunging to surging waves occurs when the Iribarren number is above a critical value

Transition value for Iribarren number:

$$scr := \text{for } i \in 0..last(\text{input}^{\langle 1 \rangle})$$

$$scr_i \leftarrow \left[\frac{8.4}{1.3} \cdot (P_i)^{0.31} \cdot \left[\left(\tan(\)_i \right)^{\frac{1}{2}} \right]^{P_i+0.5} \right]$$

Expand table if required:

	0
0	2.73
1	3.18
2	3.18
3	...

Armour layer stone size (Shallow water)

Stone size for plunging waves:

$$D_{n50pl_S} := \text{for } i \in 0..last(\text{input}^{\langle 1 \rangle})$$

$$D_{n50pl_S_i} \leftarrow \frac{H_{s_i}}{.84 \cdot (P_i)^{0.18} \cdot \left(\frac{S_{d_i}}{\sqrt{N_{w_i}}} \right)^{0.2} \cdot \frac{H_{s_i}}{H_{2\%_i}} \cdot (s_i)^{-0.5}}$$

Stone size for surging waves:

$$D_{n50su_S} := \text{for } i \in 0..last(\text{input}^{\langle 1 \rangle})$$

$$D_{n50su_S_i} \leftarrow \frac{H_{s_i}}{.13 \cdot (P_i)^{-0.13} \cdot \left(\frac{S_{d_i}}{\sqrt{N_{w_i}}} \right)^{0.2} \cdot \frac{H_{s_i}}{H_{2\%_i}} \cdot (\text{slope}_i)^{0.5} \cdot (s_i)^{P_i}}$$



$$D_{n50_S} := \text{for } i \in 0.. \text{last}(\text{input}^{(3)})$$

$D_{n50_S_i}$	$\leftarrow D_{n50pl_S_i}$ if $s_i < scr_i$
$D_{n50_S_i}$	$\leftarrow D_{n50su_S_i}$ otherwise

$$\text{check_s} := \text{for } i \in 0.. \text{last}(\text{input}^{(3)})$$

check_s_i	\leftarrow "plunging waves" if $s_i < scr_i$
check_s_i	\leftarrow "surging waves" otherwise

ARMOUR LAYER RESULTS SHALLOW WATER MARGINALLY OVERTOPPED STRUCTURES

$\text{check_s} =$	$D_{n50_S} =$	$M_{50_S} =$	kg
0	0	0	0
0	"surging waves"	0.935	2124
1	"surging waves"	1 0.856	1632
2	"surging waves"	2 0.856	1632
3	"surging waves"	3 0.9	1893
4	"surging waves"	4 0.563	465
5	"surging waves"	5 0.525	376
6	"surging waves"	6 0.216	26
7	"plunging waves"	7 0.087	2
8	"plunging waves"	8 0.087	2
9	"plunging waves"	9 0.087	2
10	"plunging waves"	10 0.087	2
11	"plunging waves"	11 0.087	2
12	"plunging waves"	12 0.087	2
13	"plunging waves"	13 0.087	2
14	"plunging waves"	14 0.087	2
15	"plunging waves"	15 0.087	2
16	"plunging waves"	16 0.087	2
17	"plunging waves"	17 0.087	2
18	"plunging waves"	18 0.087	2
19	"plunging waves"	19 0.087	2
20	"plunging waves"	20 0.087	2
21	"plunging waves"	21 0.087	2
22	"plunging waves"	22 0.087	2
23	"plunging waves"	23 0.087	2
24	"plunging waves"	24 0.087	2
25	"plunging waves"	25 0.087	2
26	"plunging waves"	26 0.087	2
27	"plunging waves"	27 0.087	2
28	"plunging waves"	28 0.087	2
29	"plunging waves"	29 0.087	2
30	"plunging waves"	30 0.087	2

$$M_{50_S} := r D_{n50_S}^3$$

CALCULATIONS FOR LOW CRESTED EMERGENT STRUCTURES

Rock armour 'Dn50' on low crested emergent structures can be calculated using the Van Der Meer calculations used above and applying a reduction factor 'rD', see page 600, Eq 5.164.

$rD := \text{for } i \in 0.. \text{last}(\text{input}^{\langle 1 \rangle})$

$$rD_i \leftarrow \left(1.25 - 4.8 \cdot \frac{Rc_i}{H_{s_i}} \cdot \sqrt{\frac{s_{op_i}}{2}} \right)^{-1}$$

Expand table if required:

	0
0	1.053
1	1.013
2	1.013
3	...

Limit of above equation for deep and shallow formulas

$\text{check_1} := \text{for } i \in 0.. \text{last}(\text{input}^{\langle 1 \rangle})$

$$\left| \begin{array}{l} \text{check_1}_i \leftarrow \text{"OK"} \quad \text{if } 0 \leq \frac{Rc_i}{H_{s_i}} \cdot \sqrt{\frac{s_{op_i}}{2}} < 0.052 \\ \text{check_1}_i \leftarrow \text{"OUT OF RANGE"} \quad \text{otherwise} \end{array} \right.$$

	0
0	"OUT OF RANGE"
1	"OUT OF RANGE"
2	"OUT OF RANGE"
3	"OUT OF RANGE"
4	"OK"
5	"OK"
6	"OUT OF RANGE"
7	"OUT OF RANGE"
8	"OUT OF RANGE"
9	"OUT OF RANGE"
10	"OUT OF RANGE"
11	"OUT OF RANGE"
12	"OUT OF RANGE"
13	"OUT OF RANGE"
14	"OUT OF RANGE"
15	"OUT OF RANGE"
16	"OUT OF RANGE"
17	"OUT OF RANGE"
18	"OUT OF RANGE"
19	"OUT OF RANGE"
20	"OUT OF RANGE"
21	"OUT OF RANGE"
22	"OUT OF RANGE"
23	"OUT OF RANGE"
24	"OUT OF RANGE"
25	"OUT OF RANGE"
26	"OUT OF RANGE"
27	"OUT OF RANGE"
28	"OUT OF RANGE"
29	...

check_1 =

$\text{check_1a} := \text{for } i \in 0.. \text{last}(\text{input}^{\langle 1 \rangle})$

$$\text{check_1a}_i \leftarrow \frac{Rc_i}{H_{s_i}} \cdot \sqrt{\frac{s_{op_i}}{2}}$$

check_1a =

	0
0	0.063
1	0.055
2	0.055
3	0.069
4	...

ARMOUR LAYER CALCULATION AND RESULTS LOW CRESTED EMERGENT STRUCTURES (DEEP WATER)

$$D_{n50_rDD} := \text{for } i \in 0.. \text{last}(\text{input}^{(1)})$$

$$D_{n50_rDD}_i \leftarrow rD_i \cdot D_{n50_D}_i$$

$$M_{50_rDD} := r D_{n50_rDD}^3$$

$$D_{n50_rDD} =$$

	0
0	0.963
1	0.843
2	0.843
3	0.949
4	0.526
5	0.443
6	0.172
7	-17.046
8	-17.046
9	-17.046
10	-17.046
11	-17.046
12	-17.046
13	-17.046
14	-17.046
15	-17.046
16	-17.046
17	-17.046
18	-17.046
19	-17.046
20	-17.046
21	-17.046
22	-17.046
23	-17.046
24	-17.046
25	-17.046
26	-17.046
27	-17.046
28	-17.046
29	...

$$\text{m}$$

$$M_{50_rDD} =$$

	0
0	2324.001
1	1555.995
2	1555.995
3	2224.668
4	378.809
5	225.833
6	13.149
7	-12878207.372
8	-12878207.372
9	-12878207.372
10	-12878207.372
11	-12878207.372
12	-12878207.372
13	-12878207.372
14	-12878207.372
15	-12878207.372
16	-12878207.372
17	-12878207.372
18	-12878207.372
19	-12878207.372
20	-12878207.372
21	-12878207.372
22	-12878207.372
23	-12878207.372
24	-12878207.372
25	-12878207.372
26	-12878207.372
27	-12878207.372
28	-12878207.372
29	...

$$\text{kg}$$

ARMOUR LAYER CALCULATION AND RESULTS LOW CRESTED EMERGENT STRUCTURES (SHALLOW WATER)

$$D_{n50_rDS} := \text{for } i \in 0.. \text{last}(\text{input} \langle 1 \rangle)$$

$$D_{n50_rDS}_i \leftarrow rD_i \cdot D_{n50_S}_i$$

$$M_{50_rDS} := r D_{n50_rDS}^3$$

$$D_{n50_rDS} =$$

	0
0	0.984
1	0.867
2	0.867
3	0.98
4	0.558
5	0.495
6	0.163
7	-12.582
8	-12.582
9	-12.582
10	-12.582
11	-12.582
12	-12.582
13	-12.582
14	-12.582
15	-12.582
16	-12.582
17	-12.582
18	-12.582
19	-12.582
20	-12.582
21	-12.582
22	-12.582
23	-12.582
24	-12.582
25	-12.582
26	-12.582
27	-12.582
28	-12.582
29	...

m

$$M_{50_rDD} =$$

	0
0	2324.001
1	1555.995
2	1555.995
3	2224.668
4	378.809
5	225.833
6	13.149
7	-12878207.372
8	-12878207.372
9	-12878207.372
10	-12878207.372
11	-12878207.372
12	-12878207.372
13	-12878207.372
14	-12878207.372
15	-12878207.372
16	-12878207.372
17	-12878207.372
18	-12878207.372
19	-12878207.372
20	-12878207.372
21	-12878207.372
22	-12878207.372
23	-12878207.372
24	-12878207.372
25	-12878207.372
26	-12878207.372
27	-12878207.372
28	-12878207.372
29	...

kg



RESULTS

MARGINALLY OVERTOPPED DEEP WATER

	0		0		
$D_{n50_D} =$	0	0.915	$M_{50_D} =$	0	1990
	1	0.832		1	1497
	2	0.832		2	1497
	3	0.871		3	1720
	4	0.532		4	391
	5	0.47		5	270
	6	0.227		6	30
	7	0.117		7	4
	8	0.117		8	4
	9	0.117		9	4
	10	0.117		10	4
	11	0.117		11	4
	12	0.117		12	4
	13	0.117		13	4
	14	...		14	...

MARGINALLY OVERTOPPED SHALLOW WATER

	0		0		
$D_{n50_S} =$	0	0.935	$M_{50_S} =$	0	2124
	1	0.856		1	1632
	2	0.856		2	1632
	3	0.9		3	1893
	4	0.563		4	465
	5	0.525		5	376
	6	0.216		6	26
	7	0.087		7	2
	8	0.087		8	2
	9	0.087		9	2
	10	0.087		10	2
	11	0.087		11	2
	12	0.087		12	2
	13	0.087		13	2
	14	...		14	...

EMERGENT STRUCTURES DEEP WATER

	0		0		
$D_{n50_rDD} =$	0	0.963	$M_{50_rDD} =$	0	2324.001
	1	0.843		1	1555.995
	2	0.843		2	1555.995
	3	0.949		3	2224.668
	4	0.526		4	378.809
	5	0.443		5	225.833
	6	0.172		6	13.149
	7	-17.046		7	-12878207.372
	8	-17.046		8	-12878207.372
	9	-17.046		9	-12878207.372
	10	-17.046		10	-12878207.372
	11	-17.046		11	-12878207.372
	12	-17.046		12	-12878207.372
	13	-17.046		13	-12878207.372
	14	...		14	...

EMERGENT STRUCTURES SHALLOW WATER

	0		0		
$D_{n50_rDS} =$	0	0.984	$M_{50_rDS} =$	0	2480.952
	1	0.867		1	1696.822
	2	0.867		2	1696.822
	3	0.98		3	2447.178
	4	0.558		4	450.542
	5	0.495		5	314.648
	6	0.163		6	11.334
	7	-12.582		7	-5178364.591
	8	-12.582		8	-5178364.591
	9	-12.582		9	-5178364.591
	10	-12.582		10	-5178364.591
	11	-12.582		11	-5178364.591
	12	-12.582		12	-5178364.591
	13	-12.582		13	-5178364.591
	14	...		14	...

MARGINALLY OVERTOPPED DEEP WATER
MARGINALLY OVERTOPPED SHALLOW WATER

	0		0		
$D_{n50_D} =$	0	0.915	$M_{50_D} =$	0	1990
	1	0.832		1	1497
	2	0.832		2	1497
	3	0.871		3	1720
	4	0.532		4	391
	5	0.47		5	270
	6	0.227		6	30
	7	0.117		7	4
	8	0.117		8	4
	9	0.117		9	4
	10	0.117		10	4
	11	0.117		11	4
	12	0.117		12	4
	13	0.117		13	4
	14	...		14	...

	0		0		
$D_{n50_S} =$	0	0.935	$M_{50_S} =$	0	2124
	1	0.856		1	1632
	2	0.856		2	1632
	3	0.9		3	1893
	4	0.563		4	465
	5	0.525		5	376
	6	0.216		6	26
	7	0.087		7	2
	8	0.087		8	2
	9	0.087		9	2
	10	0.087		10	2
	11	0.087		11	2
	12	0.087		12	2
	13	0.087		13	2
	14	...		14	...

EMERGENT STRUCTURES DEEP WATER
EMERGENT STRUCTURES SHALLOW WATER

	0		0		
$D_{n50_rDD} =$	0	0.963	$M_{50_rDD} =$	0	2324.001
	1	0.843		1	1555.995
	2	0.843		2	1555.995
	3	0.949		3	2224.668
	4	0.526		4	378.809
	5	0.443		5	225.833
	6	0.172		6	13.149
	7	-17.046		7	-12878207.372
	8	-17.046		8	-12878207.372
	9	-17.046		9	-12878207.372
	10	-17.046		10	-12878207.372
	11	-17.046		11	-12878207.372
	12	-17.046		12	-12878207.372
	13	-17.046		13	-12878207.372
	14	...		14	...

	0		0		
$D_{n50_rDS} =$	0	0.984	$M_{50_rDS} =$	0	2480.952
	1	0.867		1	1696.822
	2	0.867		2	1696.822
	3	0.98		3	2447.178
	4	0.558		4	450.542
	5	0.495		5	314.648
	6	0.163		6	11.334
	7	-12.582		7	-5178364.591
	8	-12.582		8	-5178364.591
	9	-12.582		9	-5178364.591
	10	-12.582		10	-5178364.591
	11	-12.582		11	-5178364.591
	12	-12.582		12	-5178364.591
	13	-12.582		13	-5178364.591
	14	...		14	...

Which_Van := for i ∈ 0..last(input^{i})

Which_Van _i ← "Deep water" if ht _i > 3·H _{s_i}
Which_Van _i ← "Shallow water" otherwise

$$\text{OM_temp} := \left[\begin{array}{l} \text{for } i \in 0.. \text{last}(\text{input}^{\langle 1 \rangle}) \\ a_{i,0} \leftarrow (\text{input}^{\langle 0 \rangle})_i \\ a_{i,1} \leftarrow \text{Which_Van}_i \\ a_{i,2} \leftarrow \left(\frac{\text{ht}}{3 \cdot H_s} \right)_i \\ a_{i,3} \leftarrow \frac{M_{50_D_i}}{\text{kg}} \\ a_{i,4} \leftarrow \frac{M_{50_S_i}}{\text{kg}} \\ a_{i,5} \leftarrow \text{check_1}_i \\ a_{i,6} \leftarrow \text{input}_{i,9} \\ a_{i,7} \leftarrow \frac{M_{50_rDD_i}}{\text{kg}} \\ a_{i,8} \leftarrow \frac{M_{50_rDS_i}}{\text{kg}} \end{array} \right]$$

"Defense Length"	"Which formula valid due to ht "	"Factor for ht/3Hs"	"M50 Deep W [kg]"	"M50_Shallow W [kg]"	"Che
OM_temp _{0,0}	OM_temp _{0,1}	OM_temp _{0,2}	OM_temp _{0,3}	OM_temp _{0,4}	OM_
OM_temp _{1,0}	OM_temp _{1,1}	OM_temp _{1,2}	OM_temp _{1,3}	OM_temp _{1,4}	OM_
OM_temp _{2,0}	OM_temp _{2,1}	OM_temp _{2,2}	OM_temp _{2,3}	OM_temp _{2,4}	OM_
OM_temp _{3,0}	OM_temp _{3,1}	OM_temp _{3,2}	OM_temp _{3,3}	OM_temp _{3,4}	OM_
OM_temp _{4,0}	OM_temp _{4,1}	OM_temp _{4,2}	OM_temp _{4,3}	OM_temp _{4,4}	OM_
OM_temp _{5,0}	OM_temp _{5,1}	OM_temp _{5,2}	OM_temp _{5,3}	OM_temp _{5,4}	OM_
OM_temp _{6,0}	OM_temp _{6,1}	OM_temp _{6,2}	OM_temp _{6,3}	OM_temp _{6,4}	OM_
OM_temp _{7,0}	OM_temp _{7,1}	OM_temp _{7,2}	OM_temp _{7,3}	OM_temp _{7,4}	OM_
OM_temp _{8,0}	OM_temp _{8,1}	OM_temp _{8,2}	OM_temp _{8,3}	OM_temp _{8,4}	OM_
OM_temp _{9,0}	OM_temp _{9,1}	OM_temp _{9,2}	OM_temp _{9,3}	OM_temp _{9,4}	OM_
OM_temp _{10,0}	OM_temp _{10,1}	OM_temp _{10,2}	OM_temp _{10,3}	OM_temp _{10,4}	OM_
OM_temp _{11,0}	OM_temp _{11,1}	OM_temp _{11,2}	OM_temp _{11,3}	OM_temp _{11,4}	OM_
OM_temp _{12,0}	OM_temp _{12,1}	OM_temp _{12,2}	OM_temp _{12,3}	OM_temp _{12,4}	OM_
OM_temp _{13,0}	OM_temp _{13,1}	OM_temp _{13,2}	OM_temp _{13,3}	OM_temp _{13,4}	OM_
OM_temp _{14,0}	OM_temp _{14,1}	OM_temp _{14,2}	OM_temp _{14,3}	OM_temp _{14,4}	OM_
OM_temp _{15,0}	OM_temp _{15,1}	OM_temp _{15,2}	OM_temp _{15,3}	OM_temp _{15,4}	OM_
OM_temp _{16,0}	OM_temp _{16,1}	OM_temp _{16,2}	OM_temp _{16,3}	OM_temp _{16,4}	OM_
OM_temp _{17,0}	OM_temp _{17,1}	OM_temp _{17,2}	OM_temp _{17,3}	OM_temp _{17,4}	OM_
OM_temp _{18,0}	OM_temp _{18,1}	OM_temp _{18,2}	OM_temp _{18,3}	OM_temp _{18,4}	OM_
OM_temp _{19,0}	OM_temp _{19,1}	OM_temp _{19,2}	OM_temp _{19,3}	OM_temp _{19,4}	OM_
OM_temp _{20,0}	OM_temp _{20,1}	OM_temp _{20,2}	OM_temp _{20,3}	OM_temp _{20,4}	OM_
OM_temp _{21,0}	OM_temp _{21,1}	OM_temp _{21,2}	OM_temp _{21,3}	OM_temp _{21,4}	OM_
OM_temp _{22,0}	OM_temp _{22,1}	OM_temp _{22,2}	OM_temp _{22,3}	OM_temp _{22,4}	OM_
OM_temp _{23,0}	OM_temp _{23,1}	OM_temp _{23,2}	OM_temp _{23,3}	OM_temp _{23,4}	OM_
OM_temp _{24,0}	OM_temp _{24,1}	OM_temp _{24,2}	OM_temp _{24,3}	OM_temp _{24,4}	OM_
OM_temp _{25,0}	OM_temp _{25,1}	OM_temp _{25,2}	OM_temp _{25,3}	OM_temp _{25,4}	OM_
OM_temp _{26,0}	OM_temp _{26,1}	OM_temp _{26,2}	OM_temp _{26,3}	OM_temp _{26,4}	OM_
OM_temp _{27,0}	OM_temp _{27,1}	OM_temp _{27,2}	OM_temp _{27,3}	OM_temp _{27,4}	OM_
OM_temp _{28,0}	OM_temp _{28,1}	OM_temp _{28,2}	OM_temp _{28,3}	OM_temp _{28,4}	OM_
OM_temp _{29,0}	OM_temp _{29,1}	OM_temp _{29,2}	OM_temp _{29,3}	OM_temp _{29,4}	OM_
OM_temp _{30,0}	OM_temp _{30,1}	OM_temp _{30,2}	OM_temp _{30,3}	OM_temp _{30,4}	OM_

Re :=
www



RESULTS TABLE FOR ARMOUR ROCK

The Van der Meer deep water formulae is viable when the water depth at the toe of the structure is larger than three times the significant wave height at the toe, otherwise the Van der Meer shallow water formula should be used. The formula which is valid is highlighted in table below. If the factor for $ht/3H_s$ is almost 1 which formula is used should be carefully considered.

	0	1	2	3	4	5
0	"Defense Length"	formula valid due to ht "	"Factor for $ht/3H_s$ "	"M50 Deep W [kg]"	"M50_Shallow W [kg]"	"Che
1	"1_Case_1"	"Shallow water"	0.379	1990.033	2124.429	"OUT OF R
2	"2_Case_1"	"Shallow water"	0.356	1496.926	1632.406	"OUT OF R
3	"3b_Case_1"	"Shallow water"	0.356	1496.926	1632.406	"OUT OF R
4	"3_Case_1"	"Shallow water"	0.347	1720.469	1892.549	"OUT OF R
5	"4_Case_1"	"Shallow water"	0.286	391.059	465.112	
6	"5_Case_1"	"Shallow water"	0.208	270.109	376.337	
7	"8b_Case_1"	"Deep water"	2.167	30.429	26.227	"OUT OF R
8	1	"Shallow water"	0.333	4.199	1.688	"OUT OF R
9	1	"Shallow water"	0.333	4.199	1.688	"OUT OF R
10	1	"Shallow water"	0.333	4.199	1.688	"OUT OF R
11	1	"Shallow water"	0.333	4.199	1.688	"OUT OF R
12	1	"Shallow water"	0.333	4.199	1.688	"OUT OF R
13	1	"Shallow water"	0.333	4.199	1.688	"OUT OF R
14	1	"Shallow water"	0.333	4.199	1.688	"OUT OF R
15	1	"Shallow water"	0.333	4.199	1.688	"OUT OF R
16	1	"Shallow water"	0.333	4.199	1.688	"OUT OF R
17	1	"Shallow water"	0.333	4.199	1.688	"OUT OF R
18	1	"Shallow water"	0.333	4.199	1.688	"OUT OF R
19	1	"Shallow water"	0.333	4.199	1.688	"OUT OF R
20	1	"Shallow water"	0.333	4.199	1.688	"OUT OF R
21	1	"Shallow water"	0.333	4.199	1.688	"OUT OF R
22	1	"Shallow water"	0.333	4.199	1.688	"OUT OF R
23	1	"Shallow water"	0.333	4.199	1.688	"OUT OF R
24	1	"Shallow water"	0.333	4.199	1.688	"OUT OF R
25	1	"Shallow water"	0.333	4.199	1.688	"OUT OF R
26	1	"Shallow water"	0.333	4.199	1.688	"OUT OF R
27	1	"Shallow water"	0.333	4.199	1.688	"OUT OF R
28	1	"Shallow water"	0.333	4.199	1.688	"OUT OF R
29	1	"Shallow water"	0.333	4.199	1.688	"OUT OF R
30	1	"Shallow water"	0.333	4.199	1.688	"OUT OF R
31	1	"Shallow water"	0.333	4.199	1.688	"OUT OF R

Project	Isles of Scilly Climate Adaptation	Calc no.	-	Project Engineer	MLO
Contract	DKR6499	Filename ref	-	Designer	
Section	Bryher	Job No.	-	Department	Engineering
Subject	Overtopping over revetments in Site 3 - Stinking Porth				

	Total Sheets	Mathcad Made by	Date	Cal Made by	Date	Checked by	Date		
ORIGINAL		CCN	25 / 05 /11						
REV 0		Text updated for external use (18/10/11)							
REV 1		LBG	14/06/16	MLO	06/07/21				
REV 2	7			MLO	14/01/2022	23/06/2022	AGC		
REV 3									
REV 4									
Superseded by Calculation no.				Date					

Objective of Calculation:

Check that the overtopping remains within the accepted limits.

Description of Calculation:

The crest width (G_c) is set as 0 and the waves are considered perpendicular to the revetment.

The overtopping is calculated using the revetment formulae.

ENVIRONMENTAL DATA

Insert wave condition at structure toe, wave direction and water level in the table below:

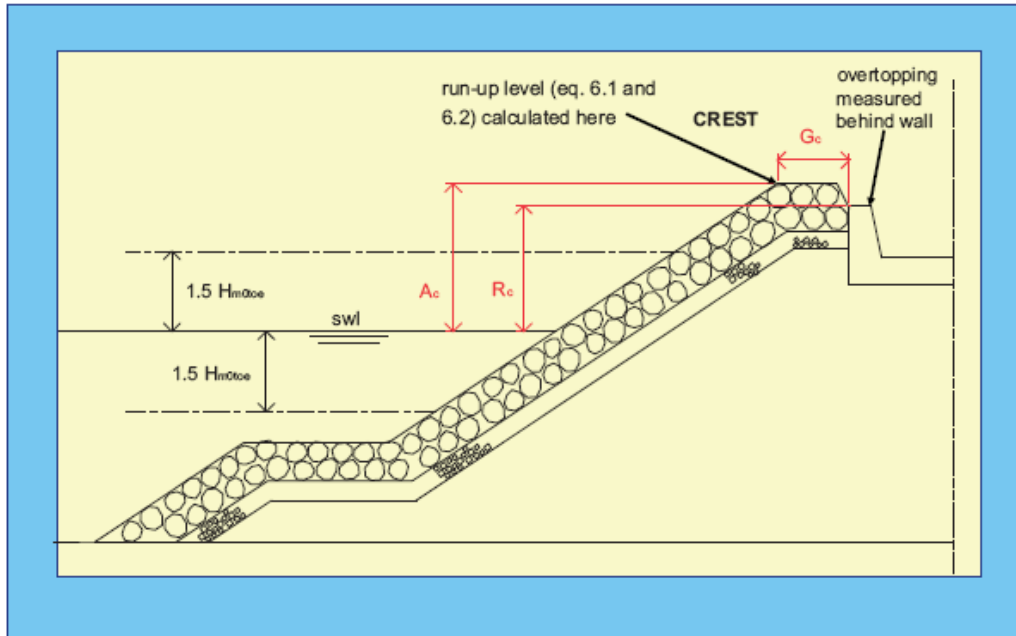

Figure 1: example of breakwater cross-section

Input data - wave conditions and structure parameters

Definition of input parameters:

H_{m0}	(m)	Significant wave height calculated from the spectrum, $H_{m0} = 4 \cdot \sqrt{m_0}$
$T_{m-1,0}$	(s)	Mean energy wave period calculated from the spectrum, $T_{m-1,0} = m^{-1}/m_0$. If not available assume $T_{m-1,0} = T_p/1.1$
SWL	(mDatum)	Sea Water Level
N_{crest}	(mDatum)	Crest level
G_c	(m)	Crest width
$\cot(\alpha)$	(-)	Slope of the structure
γ_f	(-)	Friction coefficient
β	(deg)	Angle of wave attack

Input parameters values:

data :=

	0	1	2	3	4
0	""	"Hm0"	"Tm-1,0"	"SWL"	"I"
1	"3_Case_1"	0.85	9.273	3.8	
2	"3_Case_2"	0.8	10	3.4	

Nb_cases := rows(data) - 1
Input_case := submatrix(data, 1, Nb_cases, 0, 0)
Hm0 := submatrix(data, 1, Nb_cases, 1, 1)
Tm10 := submatrix(data, 1, Nb_cases, 2, 2)
SWL := submatrix(data, 1, Nb_cases, 3, 3)
Ncrest := submatrix(data, 1, Nb_cases, 4, 4)
Gc := submatrix(data, 1, Nb_cases, 5, 5)
cotg := submatrix(data, 1, Nb_cases, 6, 6)
f := submatrix(data, 1, Nb_cases, 7, 7)
:= submatrix(data, 1, Nb_cases, 8, 8)

Definition of output parameters:

$$sm10 := \frac{2 \cdot Hm0}{9.81 \cdot Tm10^2} \quad \text{wave steepness (-)}$$

Output parameters values:

$$sm10 = \begin{pmatrix} 6.332 \times 10^{-3} \\ 5.124 \times 10^{-3} \end{pmatrix}$$

STRUCTURE AND MATERIAL PROPERTIES

BREAKWATER PARAMETERS

$$Rc := Ncrest - SWL \quad \text{freeboard}$$

$$tg := \frac{1}{cotg} \quad \text{structure slope } [\tan\alpha]$$

$$m10 := \frac{tg}{sm10^{0.5}} \quad \text{Iribarren number}$$

$$Rc = \begin{pmatrix} 2.7 \\ 3.1 \end{pmatrix} \quad tg = \begin{pmatrix} 0.5 \\ 0.5 \end{pmatrix} \quad m10 = \begin{pmatrix} 6.284 \\ 6.985 \end{pmatrix}$$

COEFFICIENTS

Roughness (or friction) coefficient

Table 6.2 page 115 of the EurOtop (2007) suggests several values of f , depending on the type of armour layer. However in case of long waves and/or steep slopes ($m > 1.8$), or impermeable cores, the friction effect of the armour layer may reduce. The Irri

In those cases the EurOtp proposes a linear interpolation of f for values of m above 1.8, between its original value (f_0) and its maximum value (1.0), thus increasing the resultant overtopping discharge. Indeed, most of the experimental data from which the formulae have been extracted are based on short period waves ($m < 1.8$), therefore many uncertainties subsists for long waves and increasing the roughness coefficient is a conservative approach.

Do you want to take the effect of long waves and/or steep slopes into account?

Set Variable **Influence** = y if so, set to "n" otherwise.

Influence_ f := "y" **Yes or No**

ORIGIN := 1

Set the tables and arrays first index at 1

_f := for i ∈ 1..Nb_cases

$$\begin{cases} \text{PROG_output}_i \leftarrow f_i & \text{if } m_{10}_i < 1.8 \\ \text{PROG_output}_i \leftarrow f_i + (1 - f_i) \cdot \frac{m_{10}_i - 1.8}{10 - 1.8} & \text{if } 1.8 < m_{10}_i < 10 \\ \text{PROG_output}_i \leftarrow 1 & \text{otherwise} \\ \text{PROG_output}_i \leftarrow f_i & \text{if Influence_ f = "n"} \end{cases}$$

$$_f = \begin{pmatrix} 0.819 \\ 0.853 \end{pmatrix} \quad \text{final roughness coefficient}$$

Oblique waves coefficient

Reduction coefficient

! Please note that for wave approach angles $\beta > 110$ overtopping rates may be set to zero. However to ensure stability and convergence of the calcsheet a small value of 0.0005 is here considered as input

Do you want to take the effect of the angle of wave attack into account?

Set Variable **Influence** = y if so, set to "n" otherwise.

Influence_ := "y" **Yes or No**

_ := for i ∈ 1..Nb_cases

$$\begin{cases} \text{PROG_output}_i \leftarrow 1 - 0.0033 \cdot \left(\frac{\beta_i}{80} \right) & \text{if } 0 \leq \beta_i \leq 80 \\ \text{PROG_output}_i \leftarrow 1 - 0.0033 \cdot (|\beta_i|) & \text{if } 80 \leq \beta_i \leq 110 \\ \text{PROG_output}_i \leftarrow 0.0005 & \text{otherwise} \\ \text{PROG_output}_i \leftarrow 1 & \text{if Influence_ = "n"} \end{cases}$$

$$_ = \begin{pmatrix} 1 \\ 1 \end{pmatrix} \quad \text{oblique wave coefficient}$$

Linear reduction of $\{H_s; T_p\}$ due to refraction for $80 < \beta < 110$

! Please consider if this is relevant to the geometry of your structure (see EurOtop section 5.3.3 and 6.3.3)

Reduction_coeff := for i ∈ 1..Nb_cases

$\text{PROG_output}_i \leftarrow \frac{110 - i}{110 - 80} \text{ if } 80 \leq i \leq 110$ $\text{PROG_output}_i \leftarrow 0.00001 \text{ if } i \geq 110$ $\text{PROG_output}_i \leftarrow 1 \text{ otherwise}$ $\text{PROG_output}_i \leftarrow 1 \text{ if Influence_} = \text{"n"}$	Please note that also in this case for wave approach angles $\beta > 110$ overtopping rates may be set to zero. However to ensure stability and convergence of the calcsheet a small value of 0.00001 is here considered as input
--	---

Reduction_coeff = $\begin{pmatrix} 1 \\ 1 \end{pmatrix}$ H_s reduction coefficient (T_p reduction coefficient = (H_s reduction coefficient)^{0.5})

$Hm0 = \begin{pmatrix} 0.85 \\ 0.8 \end{pmatrix}$ $\tan((Tm10)) = \begin{pmatrix} -0.153 \\ 0.648 \end{pmatrix}$ Reduced wave conditions

Crest width coefficient

WARNING

1) Crest width reduction factor to be used only for **rubble mound breakwater with permeable core**, therefore for smooth slopes such coefficients is to be set equal to 1. However, as sensitivity study, the user may decide to investigate the effect of a different crest width of the embankement or slope, in that case, please select the right value of Gc and set the variable Influence_Gc="y" (see below)

2) For long-period waves extra-precaution has to be taken

Do you want to use Crest reduction? if **not** please write Influence_Gc=**n** otherwise type **y** (or leave the field blank)

Influence_Gc := "y" **Yes or No**

Crest_reduction := for i ∈ 1..Nb_cases

$Cr_i \leftarrow 3.06 \cdot \exp\left(-1.5 \cdot \frac{Gc_i}{Hm0_i}\right) \text{ if } \frac{Gc_i}{Hm0_i} > 0.75$ $Cr_i \leftarrow 1 \text{ otherwise}$ $Cr_i \leftarrow 1 \text{ if Influence_Gc} = \text{"n"}$	
---	--

Crest_reduction = $\begin{pmatrix} 1 \\ 1 \end{pmatrix}$ Crest width coefficient

BREAKING OR NON-BREAKING WAVES

Regime := for i ∈ 1..Nb_cases

$$\begin{cases} \text{PROG_output}_{i,1} \leftarrow m10_i \\ \text{PROG_output}_{i,2} \leftarrow \text{"breaking / non-breaking"} \text{ if } m10_i < 5 \\ \text{PROG_output}_{i,2} \leftarrow \text{"interpolation"} \text{ if } 5 < m10_i < 7 \\ \text{PROG_output}_{i,2} \leftarrow \text{"shallow foreshores"} \text{ if } m10_i > 7 \end{cases}$$

$$\text{Regime} = \begin{pmatrix} 6.284 \text{ "interpolation"} \\ 6.985 \text{ "interpolation"} \end{pmatrix}$$

MEAN WAVE OVERTOPPING

$\overset{\text{ww}}{A} := 0.067$ $B := 4.3$ $\overset{\text{ww}}{C} := 0.2$ $D := 2.3$ $A1 := 0.21$

Coefficients for deterministic calculation of overtopping

The discharge are in l/s/m

q_breaking := for i ∈ 1..Nb_cases

$$\text{PROG_output}_i \leftarrow 1000 \text{Crest_reduction}_i \cdot \sqrt{9.81 \cdot (\text{Hm}0_i)^3} \cdot \left[\left(\frac{A}{\sqrt{\text{tg}_i}} \right) \cdot m10_i \cdot e^{\frac{B \cdot \text{Rc}_i}{\text{Hm}0_i} \cdot \frac{-1}{m10_i \cdot \text{f}_i - i}} \right]$$

q_non_breaking := for i ∈ 1..Nb_cases

$$\text{PROG_output}_i \leftarrow 1000 \text{Crest_reduction}_i \cdot \sqrt{9.81 \cdot (\text{Hm}0_i)^3} \cdot C \cdot e^{\frac{1}{\text{f}_i - i}} \cdot D \cdot \frac{\text{Rc}_i}{\text{Hm}0_i}$$

q_breaking_non_breaking := for i ∈ 1..Nb_cases

$$\text{PROG_output}_i \leftarrow \min(q_breaking_i, q_non_breaking_i)$$

q_shallow_foreshores := for i ∈ 1..Nb_cases

$$\text{PROG_output}_i \leftarrow 1000 \text{Crest_reduction}_i \cdot \sqrt{9.81 \cdot (\text{Hm}0_i)^3} \cdot A1 \cdot e^{\frac{-1}{\text{f}_i \cdot \text{Hm}0_i - i} \cdot \frac{\text{Rc}_i}{0.33 + 0.022 \cdot m10_i}}$$

$$q_breaking = \begin{pmatrix} 102.732 \\ 90.491 \end{pmatrix}$$

$$q_non_breaking = \begin{pmatrix} 0.065 \\ 0.013 \end{pmatrix}$$

$$q_breaking_non_breaking = \begin{pmatrix} 0.065 \\ 0.013 \end{pmatrix}$$

$$q_shallow_foreshores = \begin{pmatrix} 0.13 \\ 0.039 \end{pmatrix}$$

$$\text{Regime} = \begin{pmatrix} 6.284 & \text{"interpolation"} \\ 6.985 & \text{"interpolation"} \end{pmatrix}$$

q_final := for i ∈ 1..Nb_cases

```

PROG_output_{i,1} ← q_breaking_non_breaking_i if Regime_{i,2} = "breaking / non-breaking"
if Regime_{i,2} = "interpolation"
  b_i ← (7 - m10_i) / (7 - 5)
  PROG_output_{i,1} ← b_i · q_breaking_non_breaking_i + (1 - b_i) · q_shallow_foreshores_i
PROG_output_{i,1} ← q_shallow_foreshores_i if Regime_{i,2} = "shallow foreshores"

```



FINAL TABLE

Results =	"Input Case"	"Hm0"	"Tm10"	"SWL"	" m10"	"q (l/s/m)"	"Regime"	"Note"
	"3_Case_1"	0.85	9.273	3.8	6.284	0.107	"interpolation"	"EurOtop interpolation between eq 5.9 and 5.
	"3_Case_2"	0.8	10	3.4	6.985	0.039	"interpolation"	"EurOtop interpolation between eq 5.9 and 5.

COVER SHEET

Project Isles of Scilly
Contract Design Services for Off Islands Calc No. 1
Section Bryher - North Green Bay File
Subject Geobags stability Job No. DKR6499
Department Engineering Project Engineer

	Total Sheets	Made by	Date	Checked by	Date			
ORIGINAL	1	APO	04/07/2021					
REV 1	1	MLO	22/02/2022	AGC	19/08/2022			
REV 2								
REV								
REV								
REV								
REV								

Superseded by Calculation No. _____ Date _____

Subject: Geobag calculation
1 Assessment of the geobag dimensions

Assumptions:

The following assumptions have been used:

1. Waves cases of 1 in 100 years and 1 in 1 year have been used. A third case was added to study the sensitivity with a lower crest (+4.25m OD).
2. Crest level at +4.75m OD.
3. Waves have been calculated at the toe of the structure.

The more conservative initial design has been used for sizing the geobags

References

1. Pilarczyk, K.W., 1999, Geosynthetics and geosystems in hydraulic and coastal engineering,, A.A. Balkema Publisher, Rotterdam, balkema@balkema.nl.
2. Oumeraci, Hocine & Hinz, M. & Bleck, M. & Kortenhaus, Andreas. (2003). Sand-filled Geotextile Containers for Shore Protection.

	Sensitivity case		
	Initial design	Case 2	Case 3
Hs (m)	0.8	0.6	0.8
Tp (s)	5.6	4.7	5.6
L0 (m)	48.96	34.49	48.96
Crest Elevation (mODN)	4.75	4.75	4.25
SWL (mODN)	3.6	3.6	3.6
Rc (m)	1.15	1.15	0.65
Structure slope 1 in	1	1	1
Structure slope alfa	45	45	45
tan α (-)	1	1	1
ρ_w	1030	1030	1030
n	0.4	0.4	0.4
ρ_s	2650	2650	2650
ρ_E	2002	2002	2002
s	0.944	0.944	0.944
Irribarren	7.82	7.58	7.82
$N_{s, slope}$	0.98	1.00	0.98
$N_{s, crest}$	0.919375	0.9625	0.863125
SLOPE			
D	0.86	0.64	0.86
L (m)	1.22	0.90	1.22
W (m)	0.61	0.45	0.61
D(m)	0.24	0.18	0.24
weight (kg)	363	146	363
Vmax (m3)	0.1	0.0	0.1
CREST			
D	0.92	0.66	0.98
L (m)	1.30	0.93	1.39
W (m)	0.65	0.47	0.69
D(m)	0.26	0.19	0.28
Run-up			
Ru (m)	8	6	8
OVERTOPPING			
q (l/s/m)	5	1	21

C Drawings

HR Wallingford has prepared this document under the terms of the contract between them and their client, for the exclusive use of that client. HR Wallingford accepts no liability for any use of this document other than by their client and then only for the purposes for which it was prepared. No warranty is given for any third party data included in this document.

NOTES:

1. ALL DIMENSIONS ARE IN METRES UNLESS STATED OTHERWISE.



PROJECT LOCATION MAP

PROJECT KEY PLAN

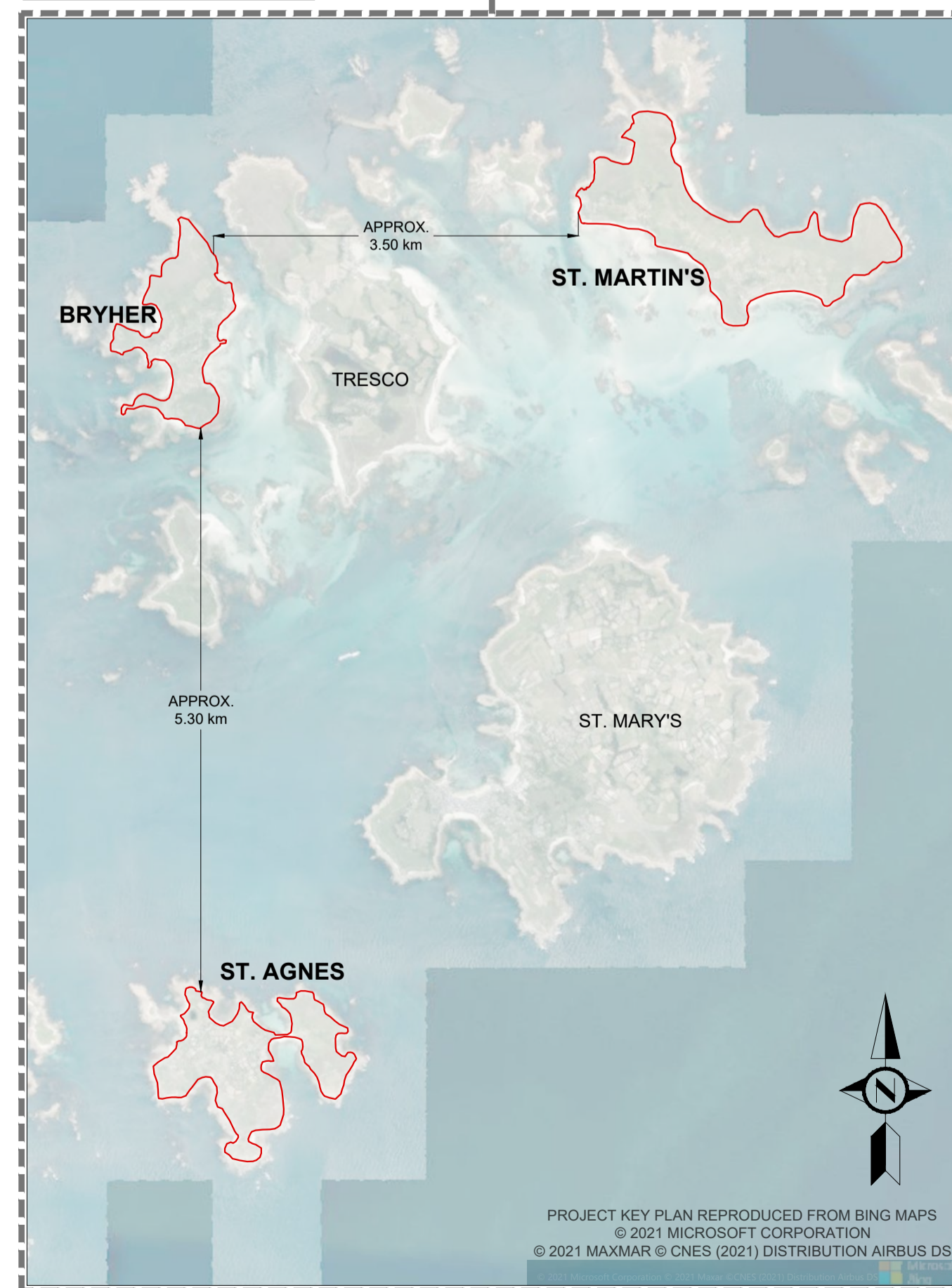

PROJECT KEY PLAN REPRODUCED FROM BING MAPS
 © 2021 MICROSOFT CORPORATION
 © 2021 MAXMAR © CNES (2021) DISTRIBUTION AIRBUS DS

01	ISSUED FOR REVIEW	MAA	APO	AGC	20 AUG 21
REV	DRAWING STATUS	DRN.	APPR	AUTH.	DATE

CLIENT:

**THE COUNCIL OF
THE ISLES OF SCILLY**

MARINE CONSULTANT:
 **HR Wallingford**
 Howbery Park, Wallingford
 Oxfordshire OX10 8BA
 United Kingdom
 Tel: +44(0)1491 835381
 Fax: +44(0)1491 832233
www.hrwallingford.com

PROJECT:
SCILLY ISLANDS

DRAWING TITLE:
PROJECT LOCATION MAP

SCALE:
 NTS

SHEET SIZE:
 A1

DRAWING No:
 DKR6499-000-D101

REV:
 01

HR Wallingford has prepared this document under the terms of the contract between them and their client, for the exclusive use of that client. HR Wallingford accepts no liability for any use of this document other than by their client and then only for the purposes for which it was prepared. No warranty is given for any third party data included in this document.

GENERAL

1. ALL DIMENSIONS ARE IN METRES UNLESS STATED OTHERWISE.
2. HORIZONTAL DATUM IS REFERENCED TO OSGB 1936 BRITISH NATIONAL GRID.
3. VERTICAL DATUM IS IN METRES, ORDNANCE DATUM.
4. SETTING OUT POINTS TO BE AGREED FOLLOWING DETAILED SURVEYS.

ROCK ARMOUR

ROCK GRADINGS ARE STANDARD GRADINGS AS DEFINED IN BS EN 13383-1 SECTION 4.2. IMPORTED ROCK SHALL BE SUPPLIED IN THE STANDARD GRADING CLASS WITH THE ASSOCIATED LIMITS AS DEFINED BELOW FOR THE RESPECTIVE GRADINGS. THE PARTICLE DENSITY SHALL BE NO LESS THAN 2600 kg/m³

40 - 200 kg

- ELL - THE MASS BELOW WHICH NO MORE THAN 5 AND 2 PERCENT PASSING BY MASS IS PERMITTED FOR HEAVY AND LIGHT/COARSE GRADINGS, RESPECTIVELY = 15 kg
- NLL - THE MASS BELOW WHICH NO MORE THAN 10 PER CENT PASSING BY MASS IS PERMITTED = 40 kg
- NUL - THE MASS BELOW WHICH NO LESS THAN 70 AND 90 PERCENT PASSING BY MASS IS PERMITTED FOR HEAVY/LIGHT AND COARSE GRADINGS, RESPECTIVELY = 200 kg
- EUL - THE MASS BELOW WHICH NO LESS THAN 97 AND 98 PERCENT PASSING BY MASS IS PERMITTED FOR HEAVY/LIGHT AND COARSE GRADINGS, RESPECTIVELY = 300 kg
- THE EFFECTIVE MEAN MASS, MEM (LOWER AND UPPER LIMITS) = 80 kg - 120 kg

1.0 - 3.0 T

- ELL - THE MASS BELOW WHICH NO MORE THAN 5 AND 2 PERCENT PASSING BY MASS IS PERMITTED FOR HEAVY AND LIGHT/COARSE GRADINGS, RESPECTIVELY = 700 kg
- NLL - THE MASS BELOW WHICH NO MORE THAN 10 PERCENT PASSING BY MASS IS PERMITTED = 1,000 kg
- NUL - THE MASS BELOW WHICH NO LESS THAN 70 AND 90 PERCENT PASSING BY MASS IS PERMITTED FOR HEAVY/LIGHT AND COARSE GRADINGS, RESPECTIVELY = 3,000 kg
- EUL - THE MASS BELOW WHICH NO LESS THAN 97 AND 98 PERCENT PASSING BY MASS IS PERMITTED FOR HEAVY/LIGHT AND COARSE GRADINGS, RESPECTIVELY = 4,500 kg
- THE EFFECTIVE MEAN MASS, MEM (LOWER AND UPPER LIMITS) = 1,700 kg - 2,100 kg

WHERE ROCK IS TO BE LOCALLY SOURCED THE ROCK SHALL ONLY BE USED WITH APPROVAL FROM THE ENGINEER AND THE FOLLOWING SHALL APPLY FOR INDIVIDUAL ROCKS:

- M MIN - 500 kg
- M MAX - 5000 kg

ARMOUR ROCK SHALL BE INDIVIDUALLY PLACED TO ACHIEVE A DENSE, FULLY INTERLOCKED ARMoured SLOPE SO THAT EACH ROCK IS SECURELY HELD IN PLACE BY ITS NEIGHBOURS. PLACING SHALL COMMENCE AT THE TOE AND PROCEED UPWARDS TOWARDS THE CREST. ROCKS SHALL BE LOWERED INTO PLACE INDIVIDUALLY.

TIDE TABLE

TIDE LEVELS	
mOD	
HAT	+3.40m
MHWS	+2.77m
MHWN	+1.44m
MLWN	-0.87m
MLWS	-2.18m
LAT	-2.82m

GEOTEXTILE

HPS12 OR EQUIVALENT

NONWOVEN GEOTEXTILE, STATIC PUNCTURE (CBR) 4 KN, PUSH THROUGH DISPLACEMENT 65 MM, TENSILE STRENGTH (MD/CMD) 25 KN/M, TENSILE ELONGATION (MD/CMD) 80%, CONE DROP 5 MM, PERMEABILITY M/S.

CHARACTERISTICS OF GEOTEXTILES SHALL BE DEFINED AND TESTED IN ACCORDANCE WITH BS EN 13253:2014. THE LABELLING OF THE ROLLS SHALL BE IN ACCORDANCE WITH EN 10320:1999.

FABRICS SHALL CONFORM TO THE FOLLOWING REQUIREMENTS:

- THE MATERIAL SHALL NOT SUFFER ANY SIGNIFICANT CHANGE TO ITS PHYSICAL, CHEMICAL OR ENGINEERING PROPERTIES UNDER THE INFLUENCE OF SULPHATES, CHLORIDES, ACIDS AND ALKALIS IN THE FORMS AND CONCENTRATIONS IN WHICH THEY ARE PRESENT IN THE SOILS, SEAWATER AND GROUND WATER TO BE FOUND AT THE WORKSITE.
- THE MATERIAL SHALL BE PROOF AGAINST BACTERIAL ATTACK.
- THE MARINE CONTRACTOR SHALL ENSURE THAT FILTER FABRIC IS NOT EXPOSED TO DIRECT SUNLIGHT FOR MORE THAN THE NUMBER OF DAYS WRITTEN IN THE GEOTEXTILE CE CERTIFICATE IN ACCORDANCE WITH EN 13253:2014 ANNEX B, OR A MAXIMUM OF ONE DAY IF NOT TESTED.
- THE MATERIAL SHALL PERFORM ACCORDING TO SPECIFICATION AT WORKING TEMPERATURES UP TO 55°C. IT SHALL NOT BE PERMANENTLY IMPAIRED BY TEMPORARY EXPOSURE DURING CONSTRUCTION TO TEMPERATURES UP TO 60°C.
- FILTER FABRICS SHALL BE SUPPLIED IN ROLLS AT LEAST 4.5 M WIDE. ROLL LENGTHS SHALL BE SUCH THAT THEY CAN BE LAID IN ONE OPERATION WITHOUT JOINTING, IN EACH OF THE SEPARATE SLOPING AND HORIZONTAL LENGTHS INVOLVED. ROLLS OF APPROPRIATE LENGTHS SHALL BE SUPPLIED FOR THIS PURPOSE.

FILTER FABRIC SHALL BE PLACED AND LAPPED IN ACCORDANCE WITH THE MANUFACTURER'S RECOMMENDATIONS. LAPS SHALL HAVE A MINIMUM WIDTH OF 1.0 M. WHERE THE FABRIC ABUTS A STRUCTURE, IT SHALL BE FOLDED UP AGAINST THE STRUCTURE BY A MINIMUM OF ONE LAP WIDTH. FILTER FABRIC SHALL BE SECURELY FASTENED DURING PLACING. GROUND ON WHICH FILTER FABRIC IS TO BE PLACED SHALL NOT CONTAIN UNDULATIONS WHICH MIGHT CAUSE DAMAGE TO THE FABRIC DURING PLACEMENT OF ROCK

ROCK BAGS

TYPE SPS 2T ROCK BAGS, SALIX AQUABAG OR SIMILAR APPROVED. MESH SIZE 25mm ; ROCK DIAMETER 40 - 80mm; DIAMETER = 2.1m; HEIGHT = 0.55m; VOLUME = 2.5m³; PARTICLE DENSITY MIN 2600 kg/m³.

GEOBAGS

GB600 WOVEN GEOBAGS WITH LIFTING STRAPS BY TENCATE OR SIMILAR APPROVED. OVERLAPPING PLACEMENT OF THE BAGS IS RECOMMENDED. GUIDELINES ON THE METHOD OF PLACEMENT WILL BE PROVIDED BY THE SUPPLIER.

FILL TO BE CLEAN AND SIEVED SITE WON SAND

GEOMAT

TENCATE GEOLON® ROBULON PP60 OR SIMILAR APPROVED. THE PRODUCT SHOULD BE MADE OF 100% HIGHLY DURABLE AND UV RESISTANT PP, WITH A 3 DIMENSIONAL STRUCTURE. THE MATT WILL BE PINNED FOR INSTALLATION AND 300mm COVER TO BE PROVIDED FOR PEDESTRIAN TRAFFIC.

03	ISSUED FOR APPROVAL	PGU	AGC	AUO	11 JUL 22
02	ISSUED FOR REVIEW	EZA	AGC	AUO	20 JAN 22
01	ISSUED FOR REVIEW	MAA	APO	AGC	20 AUG 21
REV	DRAWING STATUS	DRN	APPR	AUTH	DATE

CLIENT:

THE COUNCIL OF THE ISLES OF SCILLY

MARINE CONSULTANT:
**HR Wallingford**
Howbery Park, Wallingford
Oxfordshire OX10 8BA
United Kingdom
Tel: +44(0)1491 835381
Fax: +44(0)1491 832233

PROJECT:
**ISLES OF SCILLY
DESIGN SERVICES FOR OFF ISLANDS
COASTAL EROSION DEFENCE AND
DUNE MANAGEMENT**

DRAWING TITLE:

GENERAL NOTES

SCALE: NTS SHEET SIZE: A1

DRAWING No: DKR6499-000-D102 REV: 03

\\hrw-uk-local\projects\live\dkr6499-000-D102\02_General Notes_01.dwg PGU 08/07/22

HR Wallingford has prepared this document under the terms of the contract between them and their client, for the exclusive use of that client. HR Wallingford accepts no liability for any use of this document other than by their client and then only for the purposes for which it was prepared. No warranty is given for any third party data included in this document.

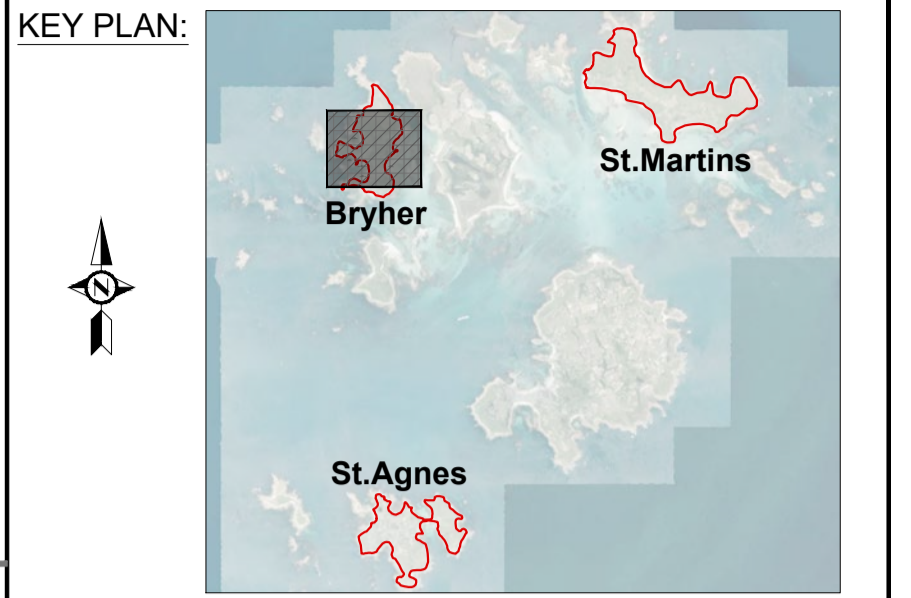

- NOTES:**
1. ALL DIMENSIONS ARE IN METRES UNLESS STATED OTHERWISE
 2. HORIZONTAL DATUM IS REFERENCED TO OSGB 1936 BRITISH NATIONAL GRID.
 3. VERTICAL DATUM IS IN METRES AND REFERENCED LIDAR SURVEY, ORDINANCE DATUM.
 4. LIDAR SURVEY DATA PROVIDED BY EA, 2020.

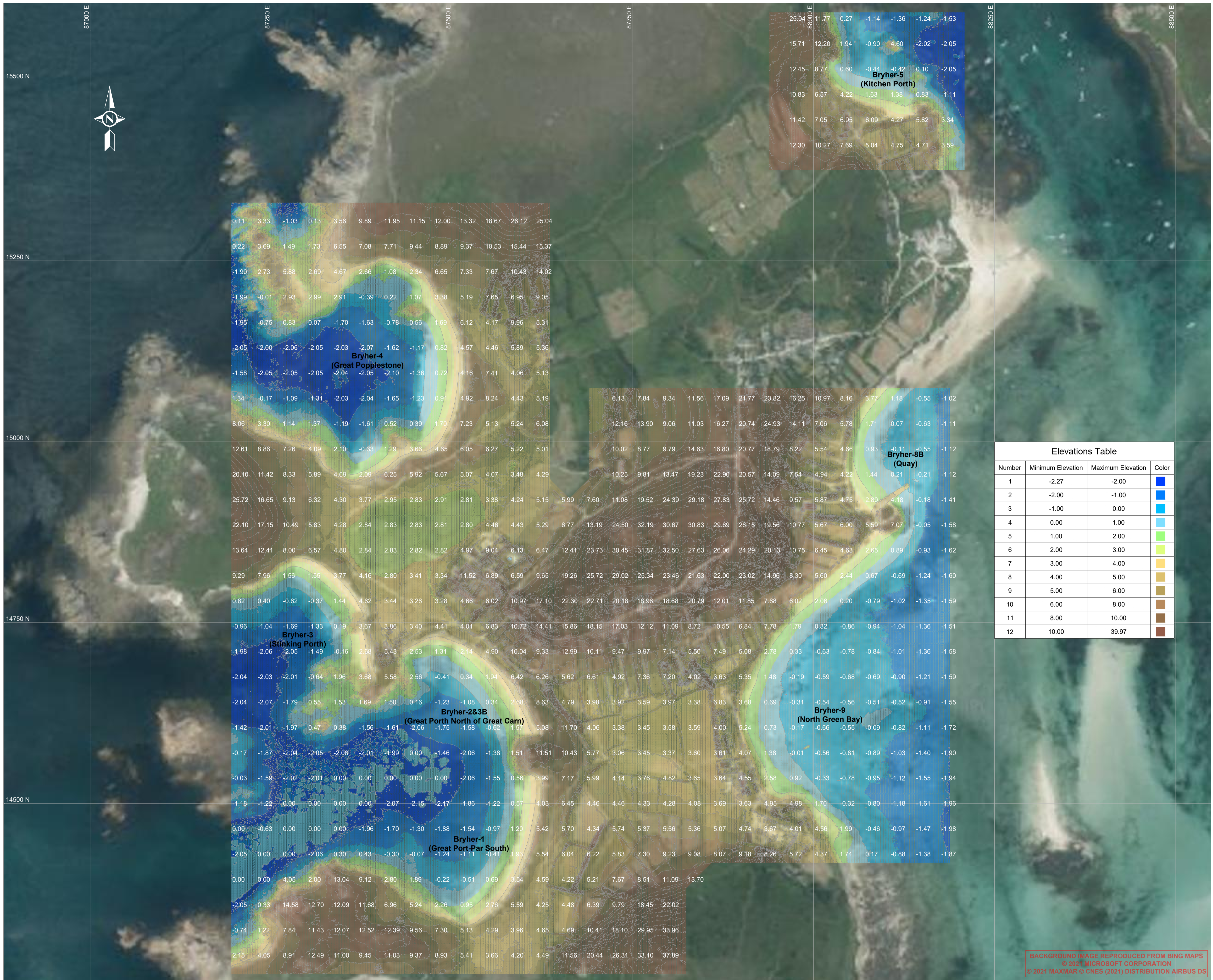

Elevations Table

Number	Minimum Elevation	Maximum Elevation	Color
1	-2.27	-2.00	Blue
2	-2.00	-1.00	Light Blue
3	-1.00	0.00	Light Cyan
4	0.00	1.00	Cyan
5	1.00	2.00	Light Green
6	2.00	3.00	Light Yellow
7	3.00	4.00	Yellow
8	4.00	5.00	Orange
9	5.00	6.00	Orange-Brown
10	6.00	8.00	Brown
11	8.00	10.00	Dark Brown
12	10.00	39.97	Dark Red

TIDE GAUGE

mOD	
HAT	+3.40m
MHWS	+2.77m
MHWN	+1.44m
MLWN	-0.87m
MLWS	-2.18m
LAT	-2.82m

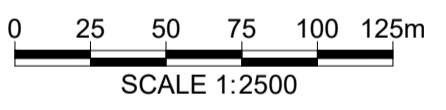

01	ISSUED FOR REVIEW	MAA	APO	AGC	02 SEP 21
REV	DRAWING STATUS	DRN	APPR	AUTH	DATE

CLIENT:
ISLES OF SCILLY
DESIGN SERVICES FOR OFF ISLANDS
COASTAL EROSION DEFENCE AND
DUNE MANAGEMENT

MARINE CONSULTANT:
HR Wallingford
 Howbery Park, Wallingford
 Oxfordshire OX10 8BA
 United Kingdom
 Tel: +44(0)1491 835381
 Fax: +44(0)1491 832233

PROJECT:
SCILLY ISLANDS

DRAWING TITLE:
LIDAR SURVEY LAYOUT
BRYHER

SCALE:
1:2500

SHEET SIZE:
A1

DRAWING No:
DKR6499-000-D104

REV:
01

BACKGROUND IMAGE REPRODUCED FROM BING MAPS
 © 2021 MICROSOFT CORPORATION
 © 2021 MAXMAR © CNES (2021) DISTRIBUTION AIRBUS DS

D:\HRW_Projects\DKR6499 - Scilly Islands\Current Drawings\DKR6499-000-D104 [01] LIDAR Survey Layout - Bryher.dwg

MAA

01/09/21

LOCATION PLAN:

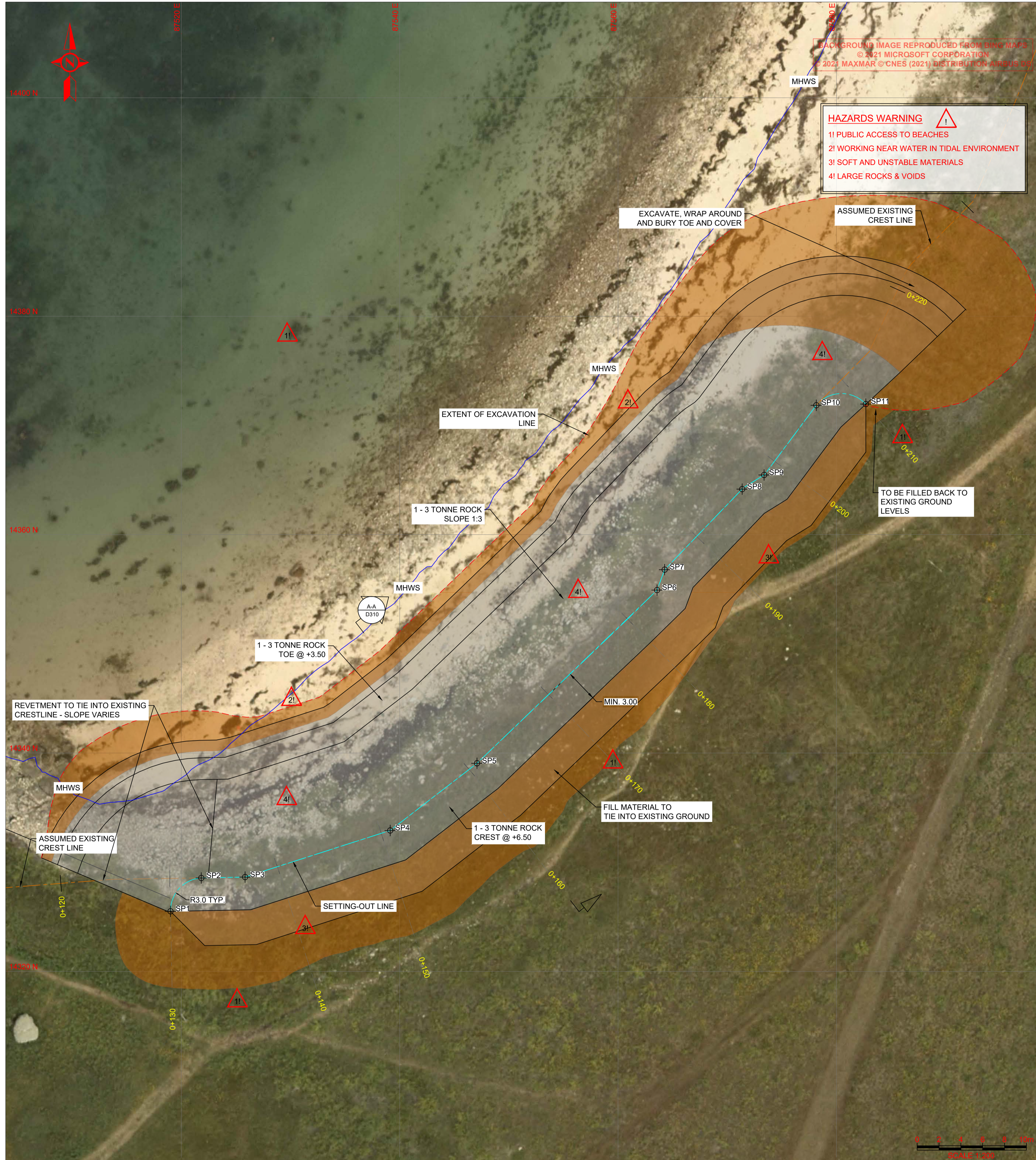

KEY PLAN:



NOTES:

- ALL DIMENSIONS ARE IN METRES UNLESS STATED OTHERWISE.
- HORIZONTAL DATUM IS REFERENCED TO OSGB 1936 BRITISH NATIONAL GRID.
- VERTICAL DATUM IS IN METRES, ORDINANCE DATUM.
- SETTING OUT POINTS TO BE AGREED FOLLOWING DETAILED TOPOGRAPHIC SURVEYS.
- ALL LEVELS TO BE CONFIRMED FOLLOWING ON SITE SURVEY.
- CONTRACTOR TO CONFIRM DETAILS OF THE INS TO EXISTING GROUND.
- FOR GENERAL NOTES REFER TO DRAWING No. DKR6499-000-D102.
- FOR TYPICAL SECTIONS REFER TO DRAWING No. DKR6499-210-D310.
- SIGNAGE WARNING OF DANGER ON CLIMBING ON ROCK TO BE PROVIDED AS PER EMPLOYERS REQUIREMENTS.
- RADI AND ADDITIONAL SETTING OUT POINTS ARE NOT INCLUDED DUE TO UNCERTAINTY ON LEVELS.

LEGEND:

- EXTENT OF FILL
- 1 - 3 TONNE ROCK
- MHWS = 2.77 mOD

SP	Easting	Northing	Elevation
SP1	87.5190	14.3255	6.500
SP2	87.5219	14.3286	6.500
SP3	87.5258	14.3286	6.500
SP4	87.5391	14.3329	6.500
SP5	87.5471	14.3391	6.500
SP6	87.5636	14.3549	6.500
SP7	87.5645	14.3571	6.500
SP8	87.5715	14.3643	6.500
SP9	87.5734	14.3655	6.500
SP10	87.5782	14.3719	6.500
SP11	87.5827	14.3720	6.500

REV	ISSUED FOR REVIEW	WST	AGC	AUO	23 AUG 22
01	ISSUED FOR REVIEW	WST	AGC	AUO	23 AUG 22
REV	DRAWING STATUS	DRN	APPR	AUTH	DATE

CLIENT: THE COUNCIL OF THE ISLES OF SCILLY

MARINE CONSULTANT: HR Wallingford
 Howbery Park, Wallingford
 Oxfordshire OX10 8BA
 United Kingdom
 Tel: +44(0)1491 835381
 Fax: +44(0)1491 832233

PROJECT: ISLES OF SCILLY
 DESIGN SERVICES FOR OFF ISLANDS
 COASTAL EROSION DEFENCE AND
 DUNE MANAGEMENT

DRAWING TITLE: BRYHER-1
 GREAT PORTH - PAR SOUTH
 GENERAL ARRANGEMENT LAYOUT

SCALE: AS SHOWN SHEET SIZE: A1
 DRAWING No: DKR6499-210-D110 REV: 01

LOCATION PLAN:

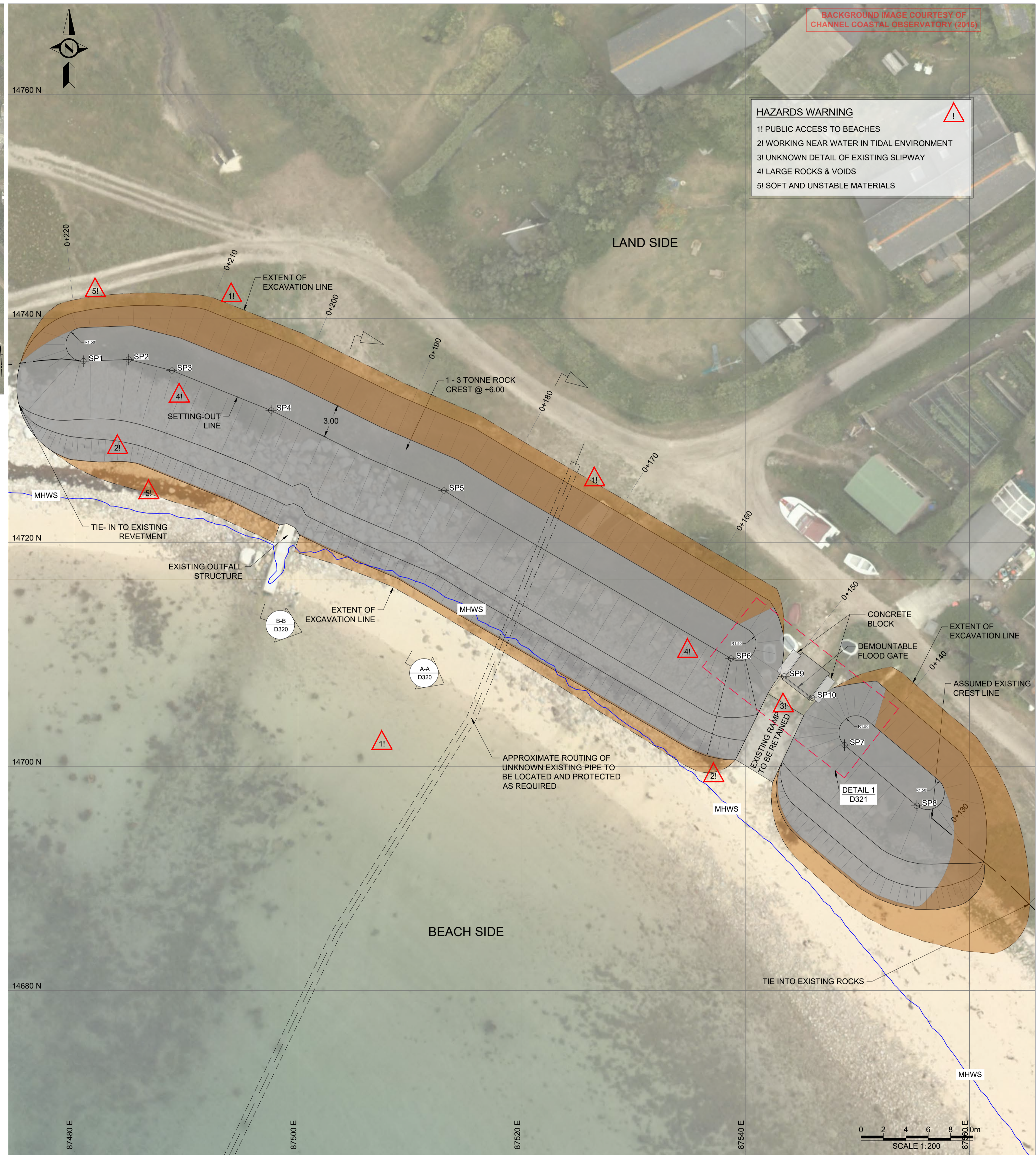
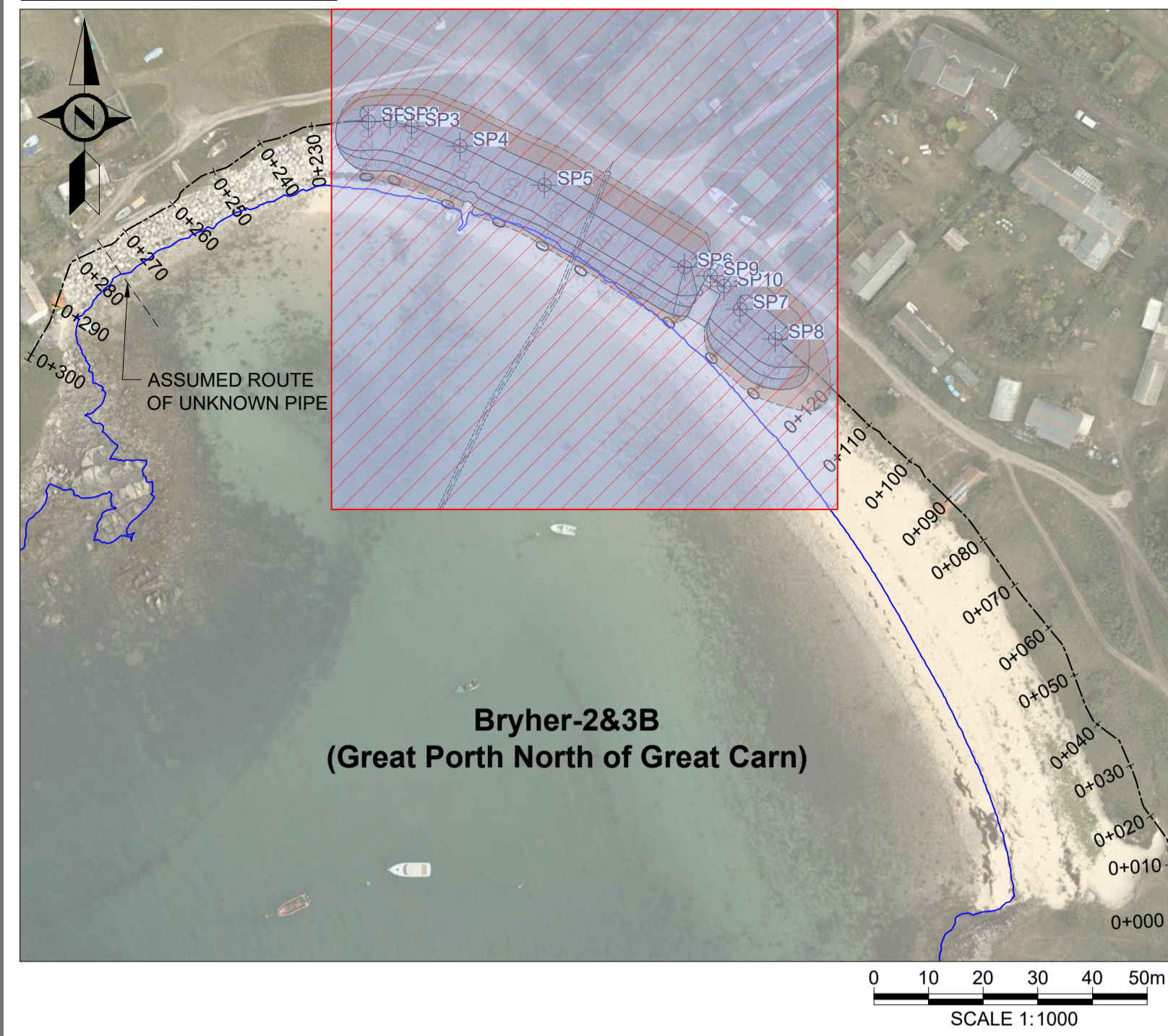

KEY PLAN:

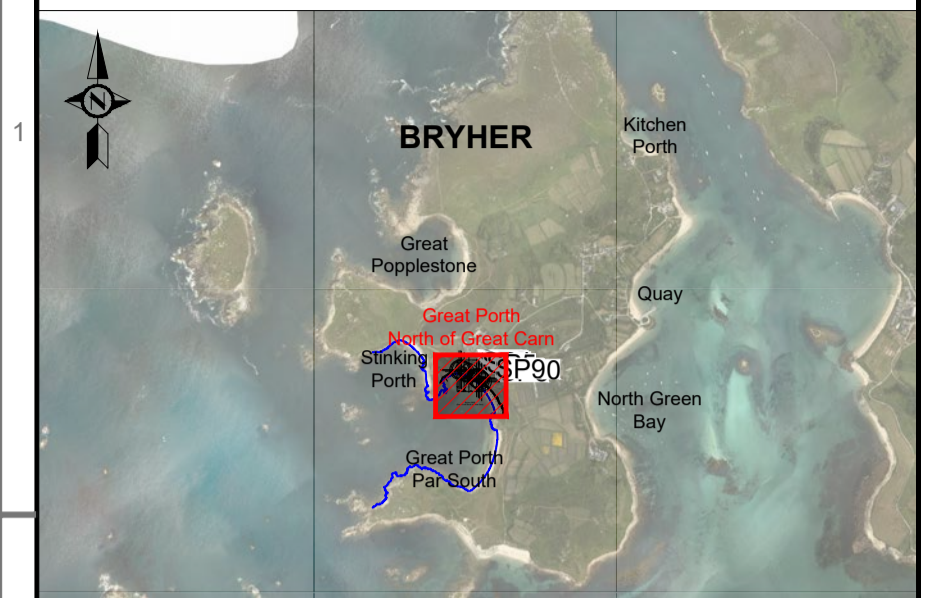

NOTES:

1. ALL DIMENSIONS ARE IN METRES UNLESS STATED OTHERWISE.
2. HORIZONTAL DATUM IS REFERENCED TO OSGB 1936 BRITISH NATIONAL GRID.
3. VERTICAL DATUM IS IN METRES, ORDNANCE DATUM.
4. SETTING OUT POINTS TO BE AGREED FOLLOWING DETAILED SURVEYS.
5. ALL LEVELS TO BE CONFIRMED FOLLOWING ON SITE SURVEY.
6. EXISTING RAMP SHOWN IS ILLUSTRATIVE OF A FIXED STRUCTURE ONLY. EXTENT TO BE CONFIRMED.
7. RAMP CREST TO BE REINSTATED WITH C20 CONCRETE.
8. FOR DETAILS ON FLOOD GATE REFER TO DRAWING No. DKR6499-210-321 AND DKR6499-210-322.
9. FOR CONCRETE DETAILS REFER TO DRAWINGS DKR6499/210/D323 AND DKR6499/210/D324.
10. FOR GENERAL NOTES REFER TO DRAWING No. DKR6499-000-D102.
11. FOR TYPICAL SECTIONS REFER TO DRAWING No. DKR6499-210-D320.
12. APPROXIMATE EXISTING PIPELINE ROUTING TAKEN FROM DESIGN DRAWING B2984-04.

LEGEND:

- FILL
- 1 - 3 TONNE ROCK
- MHWS=2.77 mOD

SP	Easting	Northing	Elevation
SP1	87.4808	14.7362	6.000
SP2	87.4849	14.7363	6.000
SP3	87.4887	14.7354	6.000
SP4	87.4976	14.7318	6.000
SP5	87.5130	14.7246	6.000
SP6	87.5387	14.7096	6.000
SP7	87.5488	14.7019	6.000
SP8	87.5553	14.6965	6.000
SP9	87.5434	14.7080	4.750
SP10	87.5459	14.7061	4.750

01	ISSUED FOR REVIEW	PGU	AGC	AUO	05 AUG 22
REV	DRAWING STATUS	DRN	APPR	AUTH.	DATE

CLIENT:
THE COUNCIL OF THE ISLES OF SCILLY

MARINE CONSULTANT:
HR Wallingford
Howbery Park, Wallingford
Oxfordshire OX10 8BA
United Kingdom
Tel: +44(0)1491 835381
Fax: +44(0)1491 832233
www.hrwallingford.com

PROJECT:
**ISLES OF SCILLY
DESIGN SERVICES FOR OFF ISLANDS
COASTAL EROSION DEFENCE AND
DUNE MANAGEMENT**

DRAWING TITLE:
**BRYHER-2&3B
GREAT PORTH NORTH OF GREAT CARN
GENERAL ARRANGEMENT LAYOUT**

SCALE: AS SHOWN SHEET SIZE: A1
DRAWING No: DKR6499-210-D111 REV: 01

I:\work\local\projects\wallingford\6499\5 deliverables\drawings\Current Drawings\DKR6499-210-D111 021_General Arrangement-Bryher
 2&3B-Great Porth North Of Great Carn_01.dwg
 PGU
 04/08/22

LOCATION PLAN:

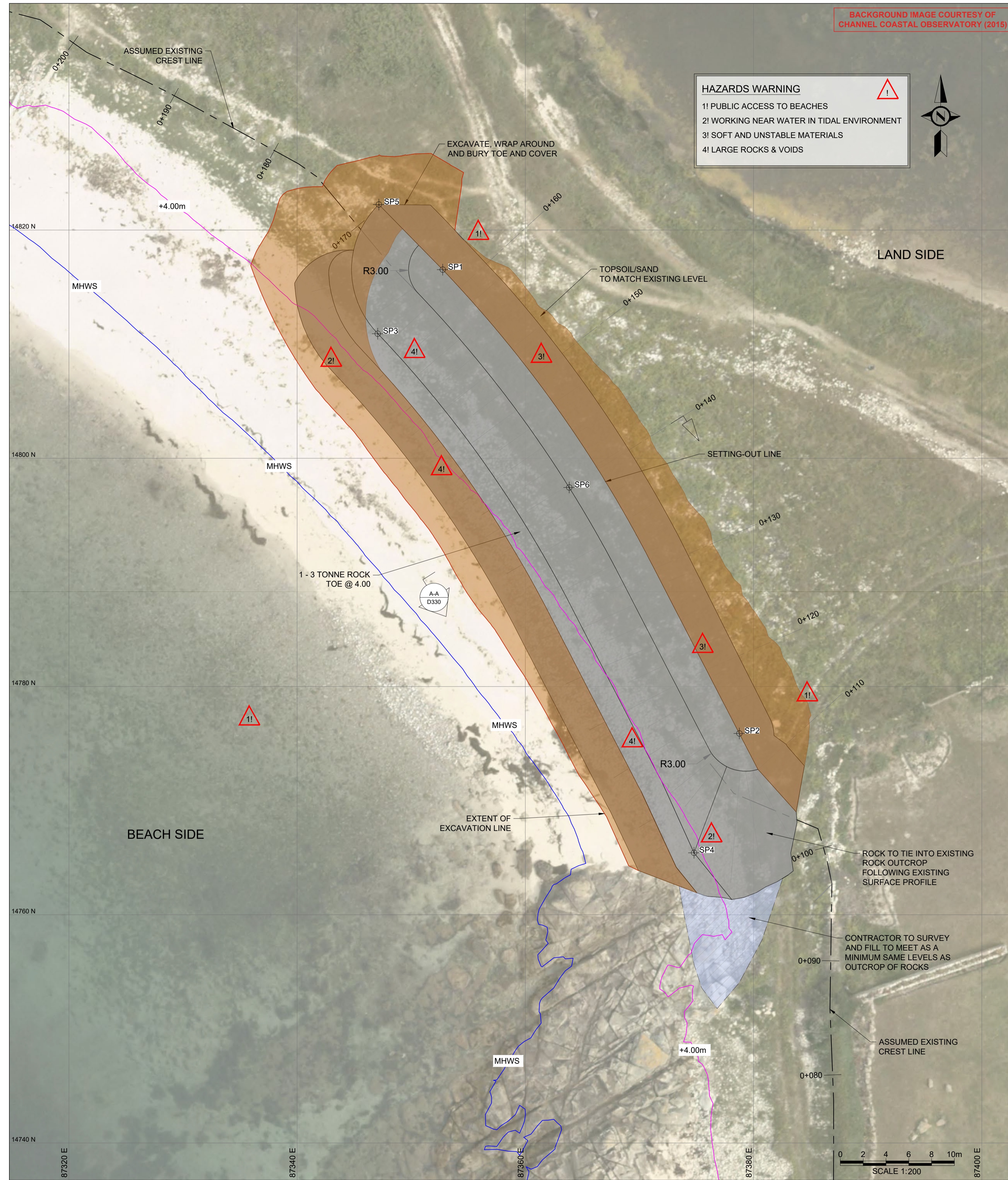
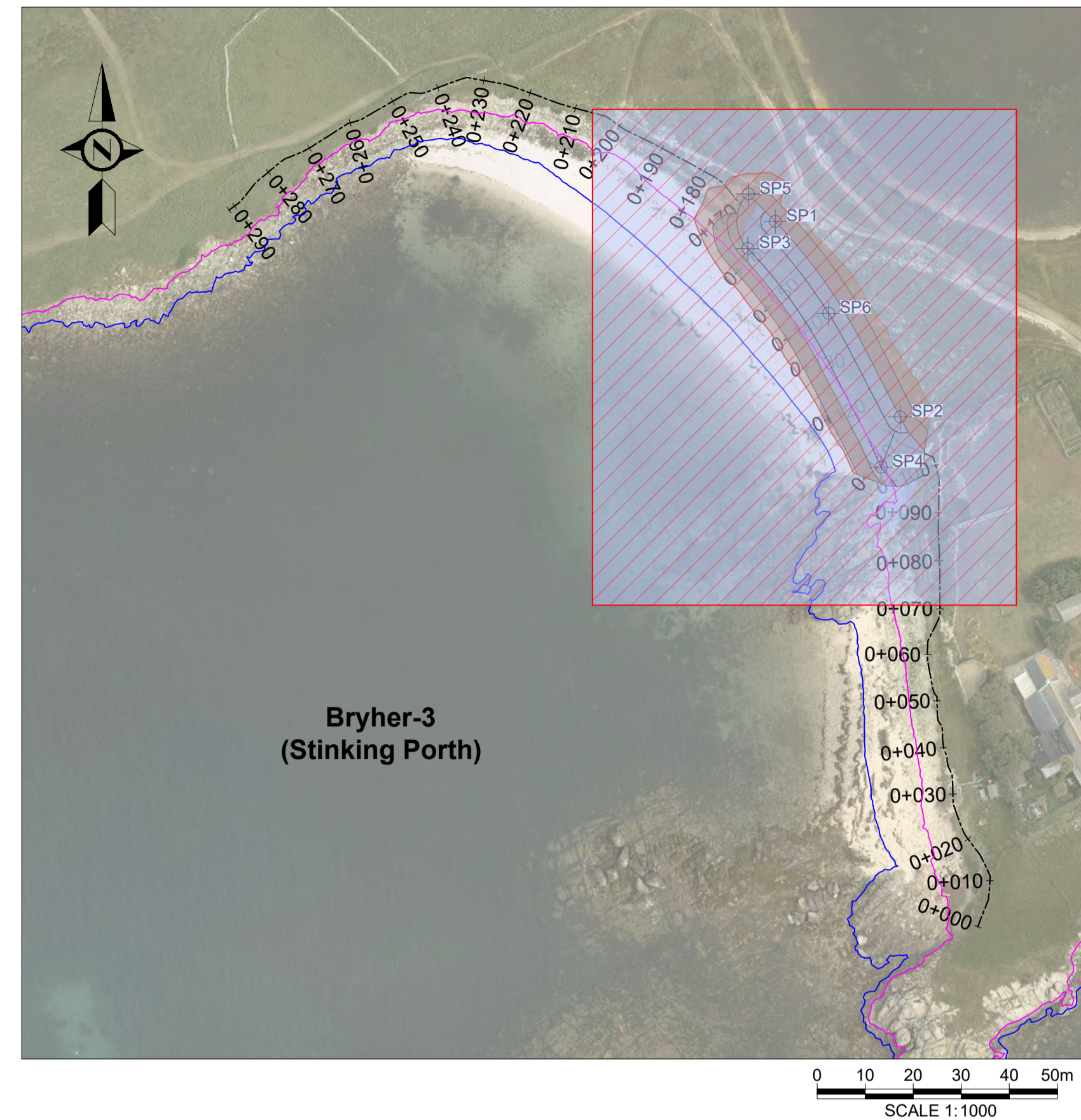

HAZARDS WARNING

- 1! PUBLIC ACCESS TO BEACHES
- 2! WORKING NEAR WATER IN TIDAL ENVIRONMENT
- 3! SOFT AND UNSTABLE MATERIALS
- 4! LARGE ROCKS & VOIDS

KEY PLAN:



NOTES:

1. ALL DIMENSIONS ARE IN METRES UNLESS STATED OTHERWISE.
2. HORIZONTAL DATUM IS REFERENCED TO OSGB 1936 BRITISH NATIONAL GRID.
3. VERTICAL DATUM IS IN METRES, ORDNANCE DATUM.
4. SETTING OUT POINTS TO BE AGREED FOLLOWING DETAILED TOPOGRAPHIC SURVEYS.
5. ALL LEVELS TO BE CONFIRMED FOLLOWING ON SITE SURVEY.
6. CONTRACTOR TO CONFIRM DETAILS OF TIE INS TO EXISTING GROUND.
7. FOR GENERAL NOTES REFER TO DRAWING No. DKR6499-000-D102.
8. FOR TYPICAL SECTIONS REFER TO DRAWING No. DKR6499-210-D330.
9. SIGNAGE WARNING OF DANGER ON CLIMBING ON ROCK TO BE PROVIDED AS PER EMPLOYERS REQUIREMENTS.
10. RADII AND ADDITIONAL SETTING OUT POINTS ARE NOT INCLUDED DUE TO UNCERTAINTY ON LEVELS.

LEGEND:

- FILL
- 1 - 3 TONNE ROCK
- MHWS=2.77 mOD
- 4.00 mOD

SP	Easting	Northing	Elevation
SP1	87.3528	14.8165	6.500
SP2	87.3788	14.7759	6.500
SP3	87.3471	14.8109	4.000
SP4	87.3748	14.7654	4.000
SP5	87.3472	14.8222	4.000
SP6	87.3638	14.7974	6.500

REV	ISSUED FOR APPROVAL	WST	AGC	AUO	26 JUN 22
01					
	DRAWING STATUS	DRN.	APPR	AUTH.	DATE

CLIENT:
THE COUNCIL OF THE ISLES OF SCILLY

MARINE CONSULTANT:
HR Wallingford
Howbery Park, Wallingford
Oxfordshire OX10 8BA
United Kingdom
Tel: +44(0)1491 835381
Fax: +44(0)1491 832233
www.hrwallingford.com

PROJECT:
**ISLES OF SCILLY
DESIGN SERVICES FOR OFF ISLANDS
COASTAL EROSION DEFENCE AND
DUNE MANAGEMENT**

DRAWING TITLE:
**BRYHER-3 STINKING PORTH
GENERAL ARRANGEMENT LAYOUT**

SCALE:
AS SHOWN

SHEET SIZE:
A1

DRAWING No:
DKR6499-210-D112

REV:
01

I:\work\local\projects\live\dkr6499\5\deliverables\drawings\Current\Drawings\DKR6499-210-D112 [01] General Arrangement-Bryher
 3-Stinking Porth.dwg
 WST
 28/06/22

LOCATION PLAN:

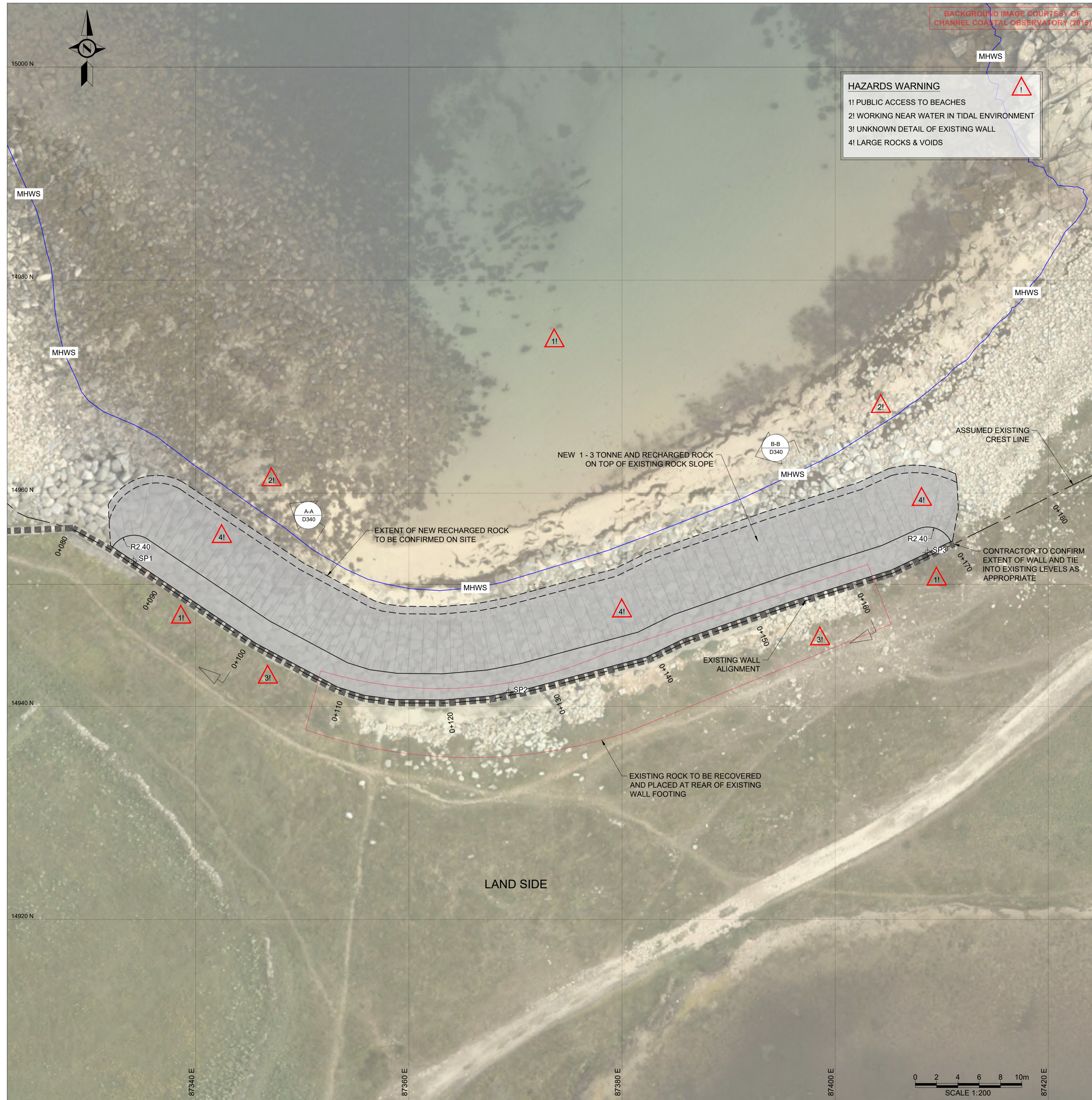
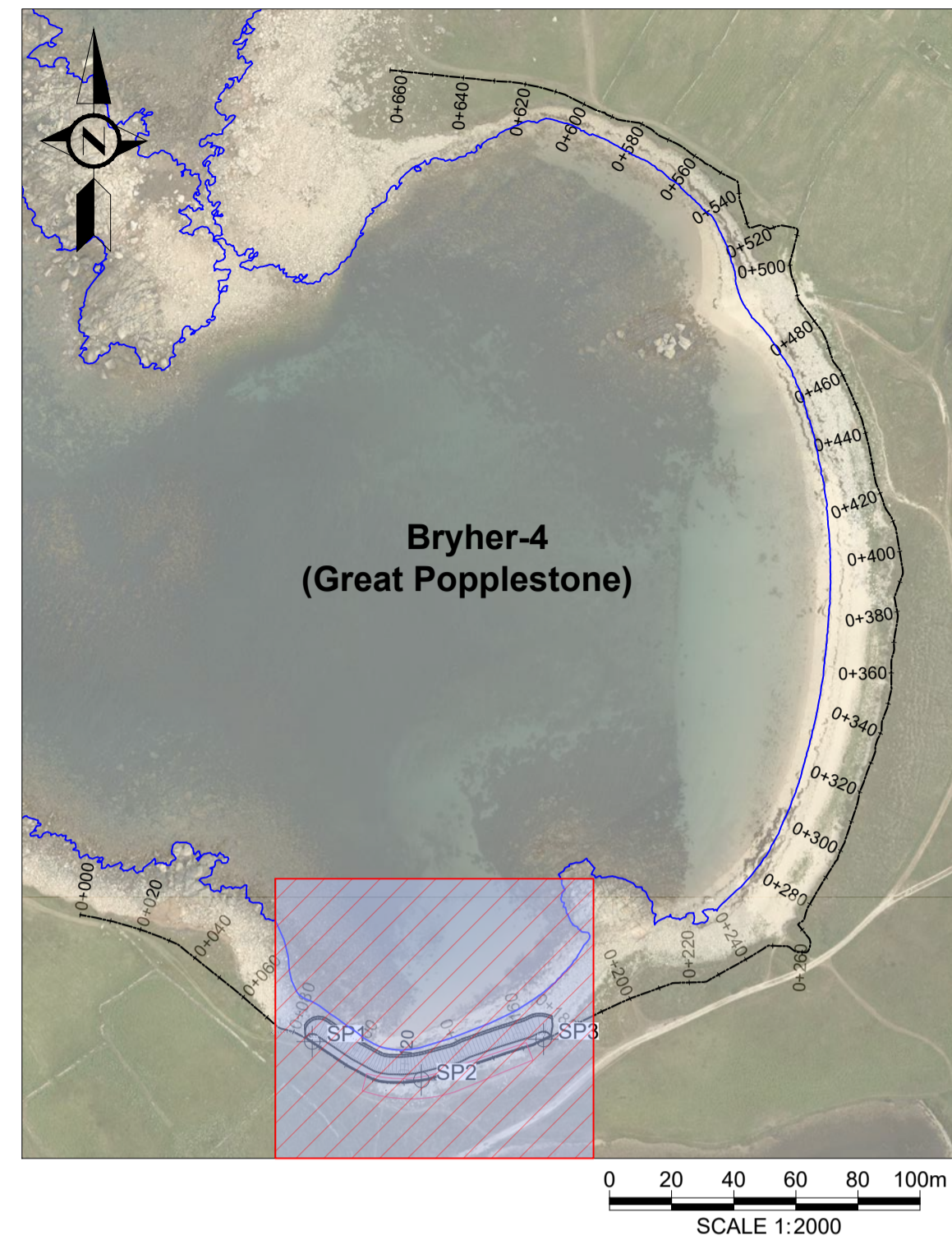

BACKGROUND IMAGE COURTESY OF CHANNEL COASTAL OBSERVATORY (2019)

HAZARDS WARNING

- 1! PUBLIC ACCESS TO BEACHES
- 2! WORKING NEAR WATER IN TIDAL ENVIRONMENT
- 3! UNKNOWN DETAIL OF EXISTING WALL
- 4! LARGE ROCKS & VOIDS

KEY PLAN:



NOTES:

1. ALL DIMENSIONS ARE IN METRES UNLESS STATED OTHERWISE.
2. HORIZONTAL DATUM IS REFERENCED TO OSGB 1936 BRITISH NATIONAL GRID.
3. VERTICAL DATUM IS IN METRES, ORDNANCE DATUM.
4. SETTING OUT POINTS ARE SEAWARD SIDE OF EXISTING WALL. TO BE AGREED FOLLOWING DETAILED TOPOGRAPHIC SURVEYS.
5. ALL LEVELS TO BE CONFIRMED FOLLOWING ON SITE SURVEY.
6. CONTRACTOR TO CONFIRM DETAILS OF THE INS TO EXISTING GROUND.
7. FOR GENERAL NOTES REFER TO DRAWING No. DKR6499-000-D102.
8. FOR TYPICAL SECTIONS REFER TO DRAWING No. DKR6499-210-D340.
9. SIGNAGE WARNING OF DANGER ON CLIMBING ON ROCK TO BE PROVIDED AS PER EMPLOYERS REQUIREMENTS.
10. RADII AND ADDITIONAL SETTING OUT POINTS ARE NOT INCLUDED DUE TO UNCERTAINTY ON LEVELS.

LEGEND:

— MHWS= 2.77 mOD

SP	Easting	Northing	Elevation
SP1	87.3342	14.9536	6.100
SP2	87.3694	14.9413	6.100
SP3	87.4087	14.9544	6.100

01	ISSUED FOR REVIEW	PGU	AGC	AUO	11 JUL 22
REV	DRAWING STATUS	DRN	APPR	AUTH.	DATE

CLIENT:

THE COUNCIL OF THE ISLES OF SCILLY

MARINE CONSULTANT:



HR Wallingford
 Howbery Park, Wallingford
 Oxfordshire OX10 8BA
 United Kingdom
 Tel: +44(0)1491 835381
 Fax: +44(0)1491 832233

PROJECT:

**ISLES OF SCILLY
 DESIGN SERVICES FOR OFF ISLANDS
 COASTAL EROSION DEFENCE AND
 DUNE MANAGEMENT**

DRAWING TITLE:

**BRYHER-4 GREAT POPPLESTONE
 GENERAL ARRANGEMENT LAYOUT**

SCALE:
 AS SHOWN

SHEET SIZE:
 A1

DRAWING No:
 DKR6499-210-D113

REV:
 01

KEY PLAN:

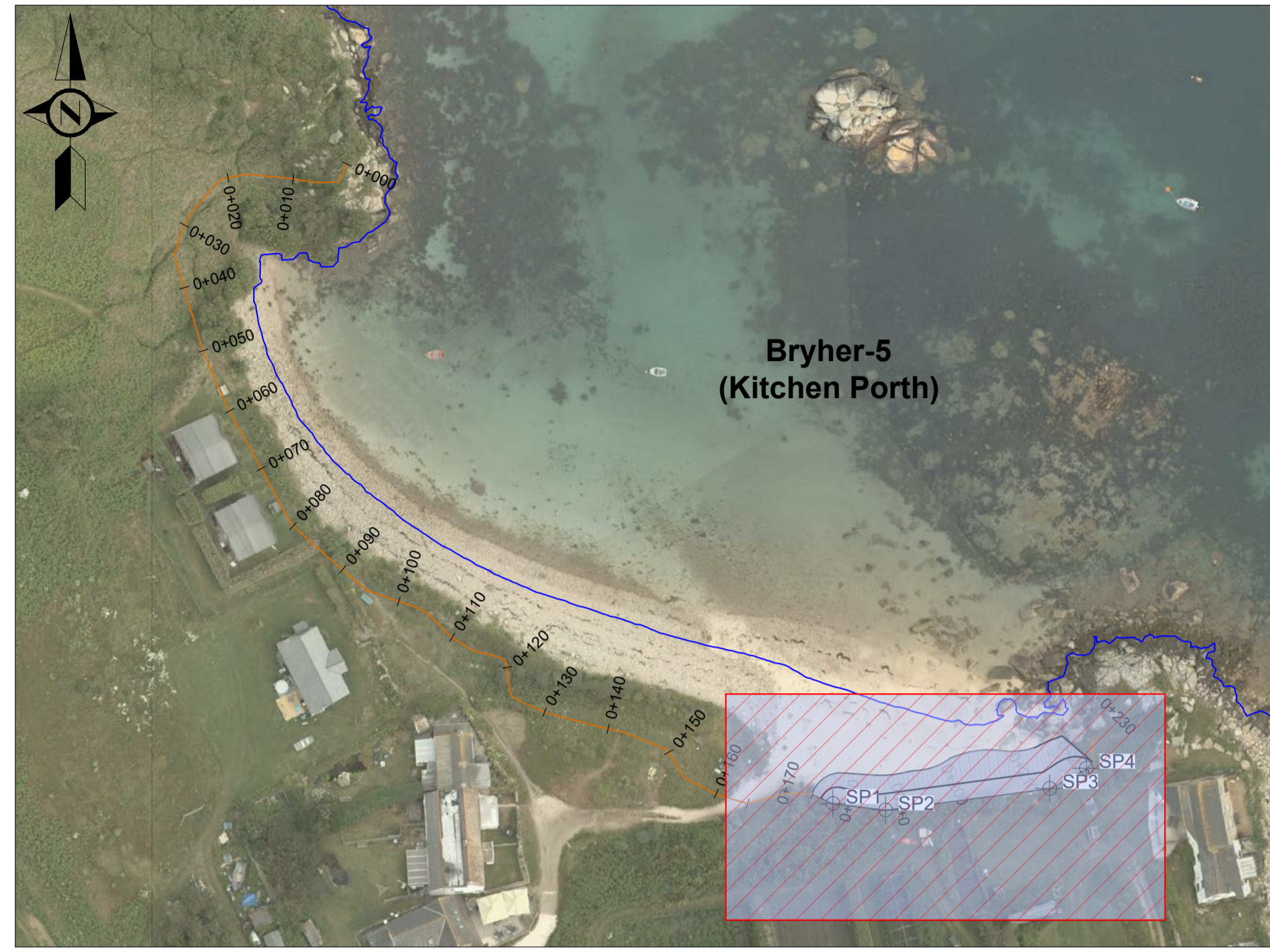

SCALE 1:1000

HAZARDS WARNING

- 1! PUBLIC ACCESS TO BEACHES
- 2! WORKING NEAR WATER IN TIDAL ENVIRONMENT
- 4! LARGE ROCKS & VOIDS

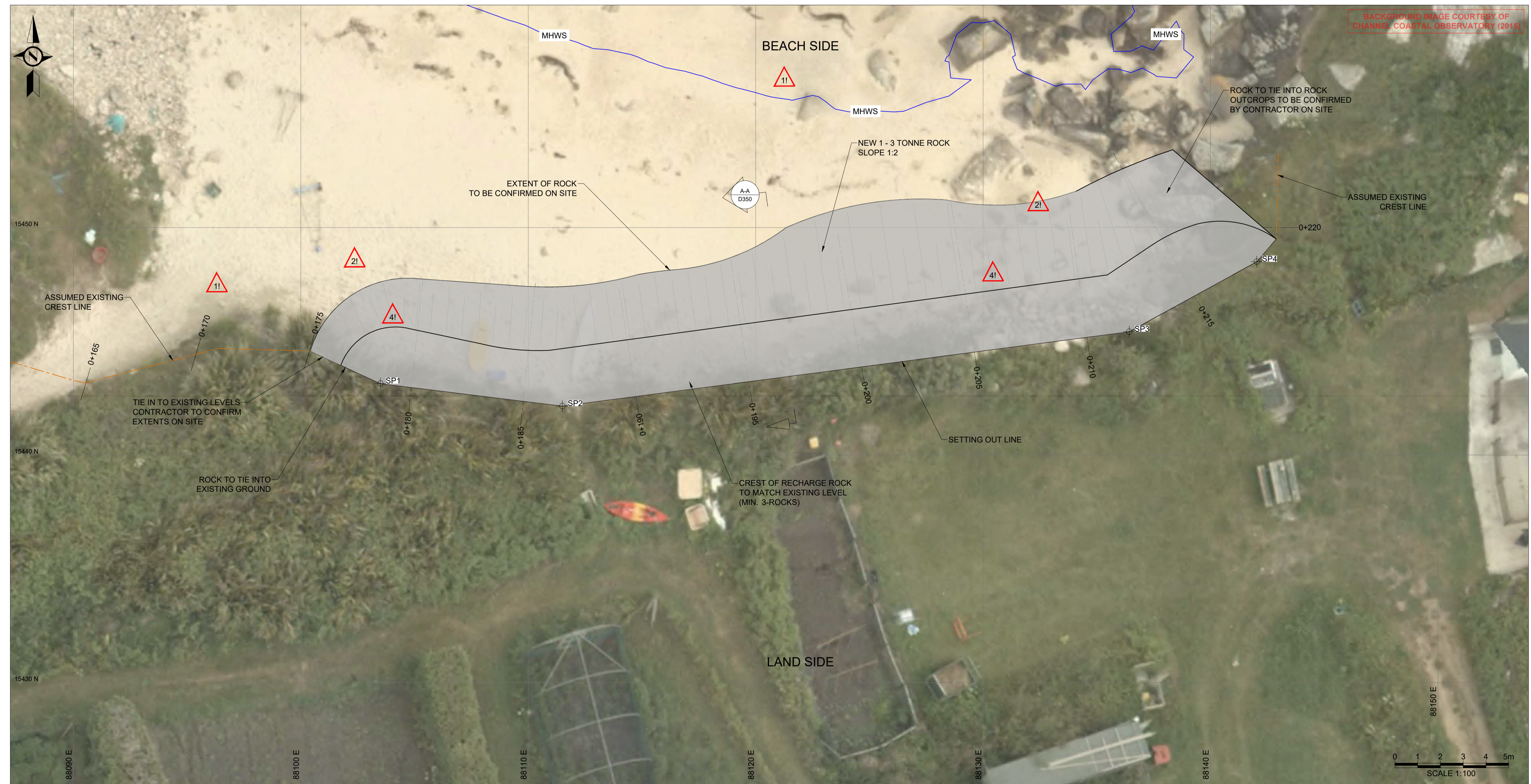

BACKGROUND IMAGE COURTESY OF CHANNEL COASTAL OBSERVATORY (2014)

HR Wallingford has prepared this document under the terms of the contract between them and their client, for the exclusive use of that client. HR Wallingford accepts no liability for any use of this document other than by their client and then only for the purposes for which it was prepared. No warranty is given for any third party data included in this document.

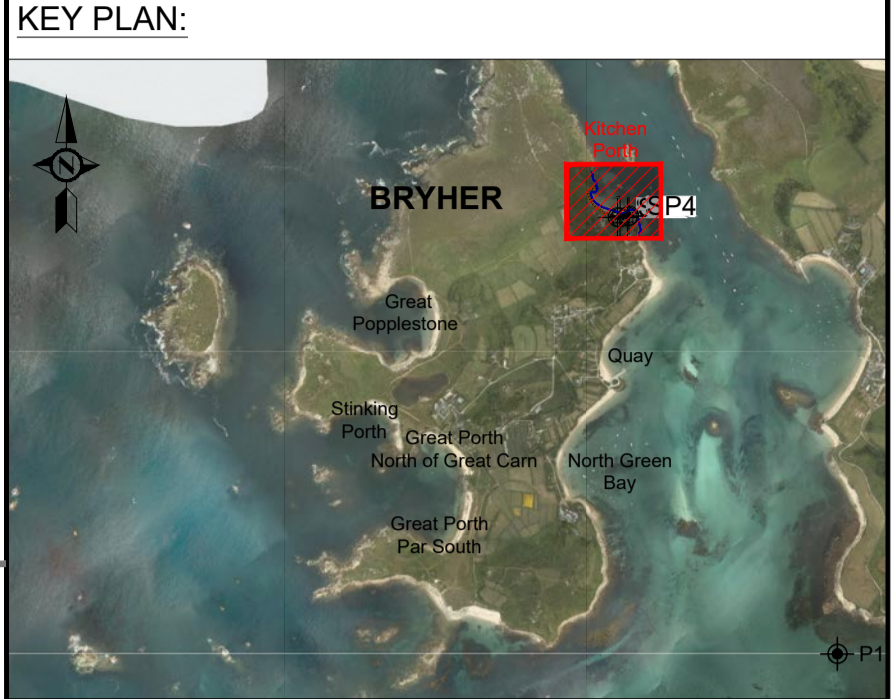

- NOTES:**
1. ALL DIMENSIONS ARE IN METRES UNLESS STATED OTHERWISE.
 2. HORIZONTAL DATUM IS REFERENCED TO OSGB 1936 BRITISH NATIONAL GRID.
 3. VERTICAL DATUM IS IN METRES, ORDNANCE DATUM.
 4. SETTING OUT POINTS TO BE AGREED FOLLOWING DETAILED TOPOGRAPHIC SURVEYS.
 5. ALL LEVELS TO BE CONFIRMED FOLLOWING ON SITE SURVEY.
 6. CONTRACTOR TO CONFIRM DETAILS OF THE INS TO EXISTING GROUND.
 7. FOR GENERAL NOTES REFER TO DRAWING No. DKR6499-000-D102.
 8. FOR TYPICAL SECTIONS REFER TO DRAWING No. DKR6499-210-D350.
 9. SIGNAGE WARNING OF DANGER ON CLIMBING ON ROCK TO BE PROVIDED AS PER EMPLOYERS REQUIREMENTS.
 10. RADII AND ADDITIONAL SETTING OUT POINTS ARE NOT INCLUDED DUE TO UNCERTAINTY ON LEVELS.

LEGEND:

- 1-3 TONNE ROCK
- MHWS=2.77 mOD

SP	Easting	Northing	Elevation
SP1	88.1035	15.4431	VARIABLES
SP2	88.1115	15.4422	VARIABLES
SP3	88.1364	15.4454	VARIABLES
SP4	88.1420	15.4485	VARIABLES

01	ISSUED FOR APPROVAL	WST	AGC	AUO	27 JUN 22
REV	DRAWING STATUS	DRN	APPR	AUTH.	DATE

CLIENT:

THE COUNCIL OF THE ISLES OF SCILLY

MARINE CONSULTANT:

HR Wallingford
 Howbery Park, Wallingford
 Oxfordshire OX10 8BA
 United Kingdom
 Tel: +44(0)1491 835381
 Fax: +44(0)1491 832233
www.hrwallingford.com

PROJECT:

**ISLES OF SCILLY
 DESIGN SERVICES FOR OFF ISLANDS
 COASTAL EROSION DEFENCE AND
 DUNE MANAGEMENT**

DRAWING TITLE:

**BRYHER-5 KITCHEN PORTH
 GENERAL ARRANGEMENT LAYOUT**

SCALE: AS SHOWN SHEET SIZE: A1

DRAWING No: DKR6499-210-D114 REV: 01

I:\work\local\projects\live\dkr6499\5_deliverables\drawings\Current Drawings\DKR6499-210-D114_011_General Arrangement-Bryher-5-Kitchen Porth.dwg
 WST
 27/06/22

LOCATION PLAN

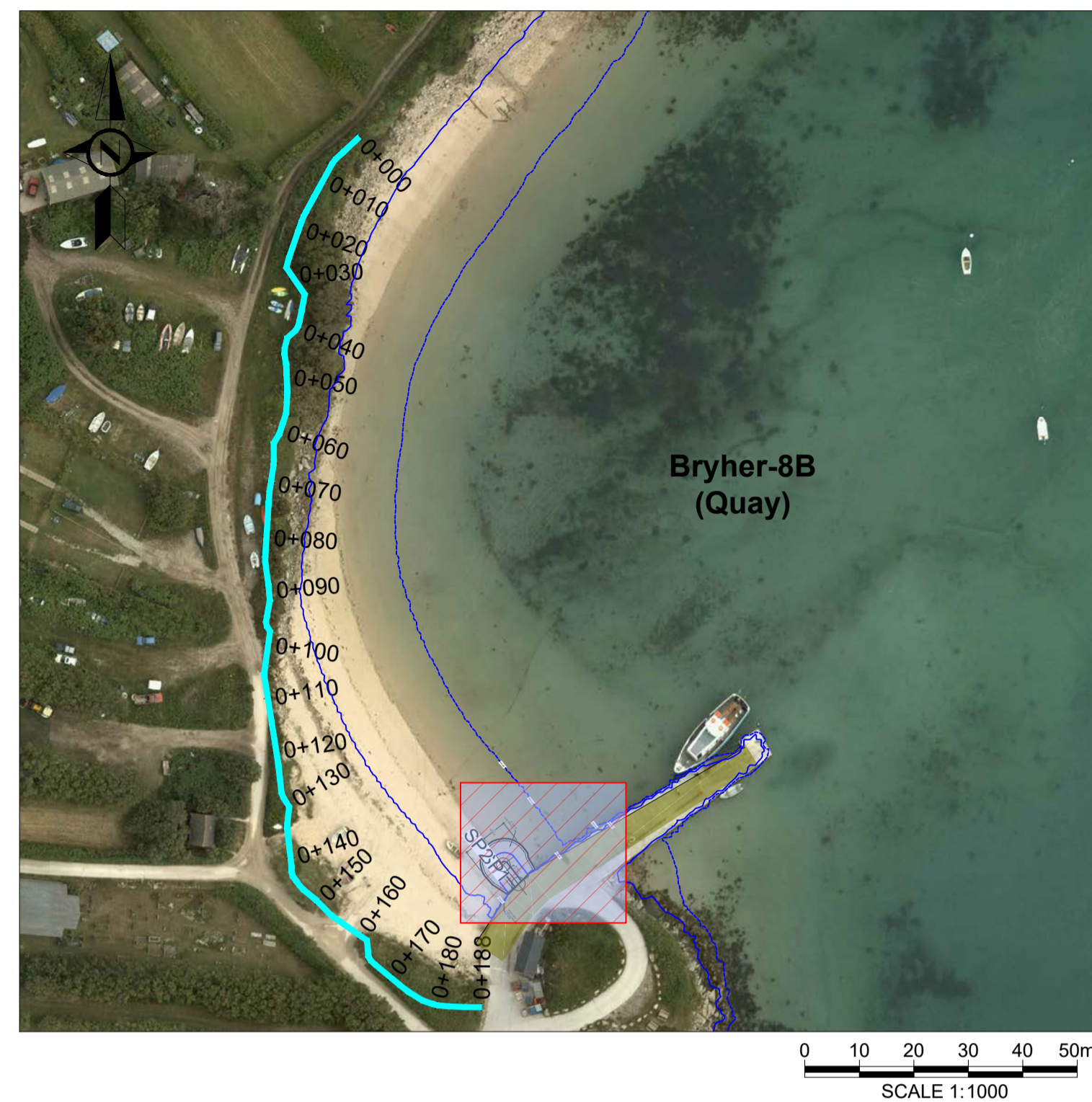

HAZARDS WARNING

- 1! PUBLIC ACCESS TO BEACHES
- 2! WORKING NEAR WATER IN TIDAL ENVIRONMENT
- 3! UNKNOWN DETAIL OF EXISTING WALL
- 4! LARGE ROCKS & VOIDS

HR Wallingford has prepared this document under the terms of the contract between them and their client, for the exclusive use of that client. HR Wallingford accepts no liability for any use of this document other than by their client and then only for the purposes for which it was prepared. No warranty is given for any third party data included in this document.

KEY PLAN:

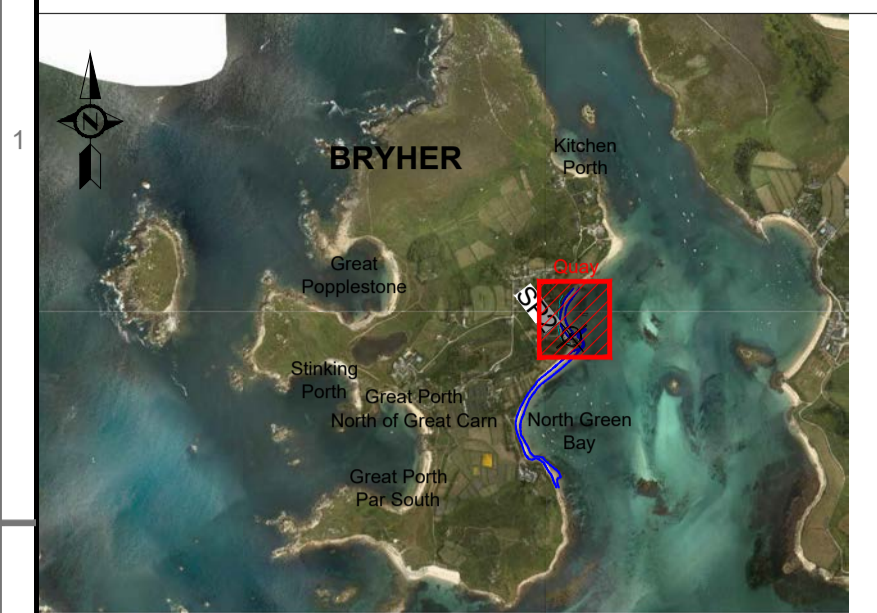

NOTES:

1. ALL DIMENSIONS ARE IN METRES UNLESS STATED OTHERWISE.
2. HORIZONTAL DATUM IS REFERENCED TO OSGB 1936 BRITISH NATIONAL GRID.
3. VERTICAL DATUM IS IN METRES, ORDNANCE DATUM.
4. SETTING OUT POINTS TO BE AGREED FOLLOWING DETAILED TOPOGRAPHIC SURVEYS.
5. ALL LEVELS TO BE CONFIRMED FOLLOWING ON SITE SURVEY.
6. CONTRACTOR TO CONFIRM DETAILS OF TIE INS TO EXISTING GROUND.
7. EXISTING QUAY EXTENTS SHOWN ARE ILLUSTRATIVE OF A FIXED STRUCTURE ONLY. QUAY EDGE COORDINATES TO BE CONFIRMED.
8. GROUYNE EXTENTS TO BE CONFIRMED ON SITE FOLLOWING DETAILED SURVEY
9. FOR GENERAL NOTES REFER TO DRAWING No. DKR6499-000-D102.
10. FOR TYPICAL SECTIONS REFER TO DRAWING No. DKR6499-210-D360.
9. SIGNAGE WARNING OF DANGER ON CLIMBING ON ROCK TO BE PROVIDED AS PER EMPLOYERS REQUIREMENTS.

LEGEND:

- 1 - 3 TONNE ROCK
- EXISTING PLATFORM
- MHWS= 2.77 mOD
- MHWN= 1.44 mOD

SP	Easting	Northing	Elevation
1	88.0860	14.9141	3.600
2	88.0832	14.9177	3.600

REV	ISSUED FOR APPROVAL	WST	AGC	AUO	27 JUN 22
01					
	DRAWING STATUS	DRN.	APPR	AUTH.	DATE

CLIENT:

THE COUNCIL OF THE ISLES OF SCILLY

MARINE CONSULTANT:



HR Wallingford
 Howbery Park, Wallingford
 Oxfordshire OX10 8BA
 United Kingdom
 Tel: +44(0)1491 835381
 Fax: +44(0)1491 832233

PROJECT:

**ISLES OF SCILLY
 DESIGN SERVICES FOR OFF ISLANDS
 COASTAL EROSION DEFENCE AND
 DUNE MANAGEMENT**

DRAWING TITLE:

**BRYHER-8B QUAY
 GENERAL ARRANGEMENT LAYOUT**

SCALE:
AS SHOWN

SHEET SIZE:
A1

DRAWING No:
DKR6499-210-D115

REV:
01

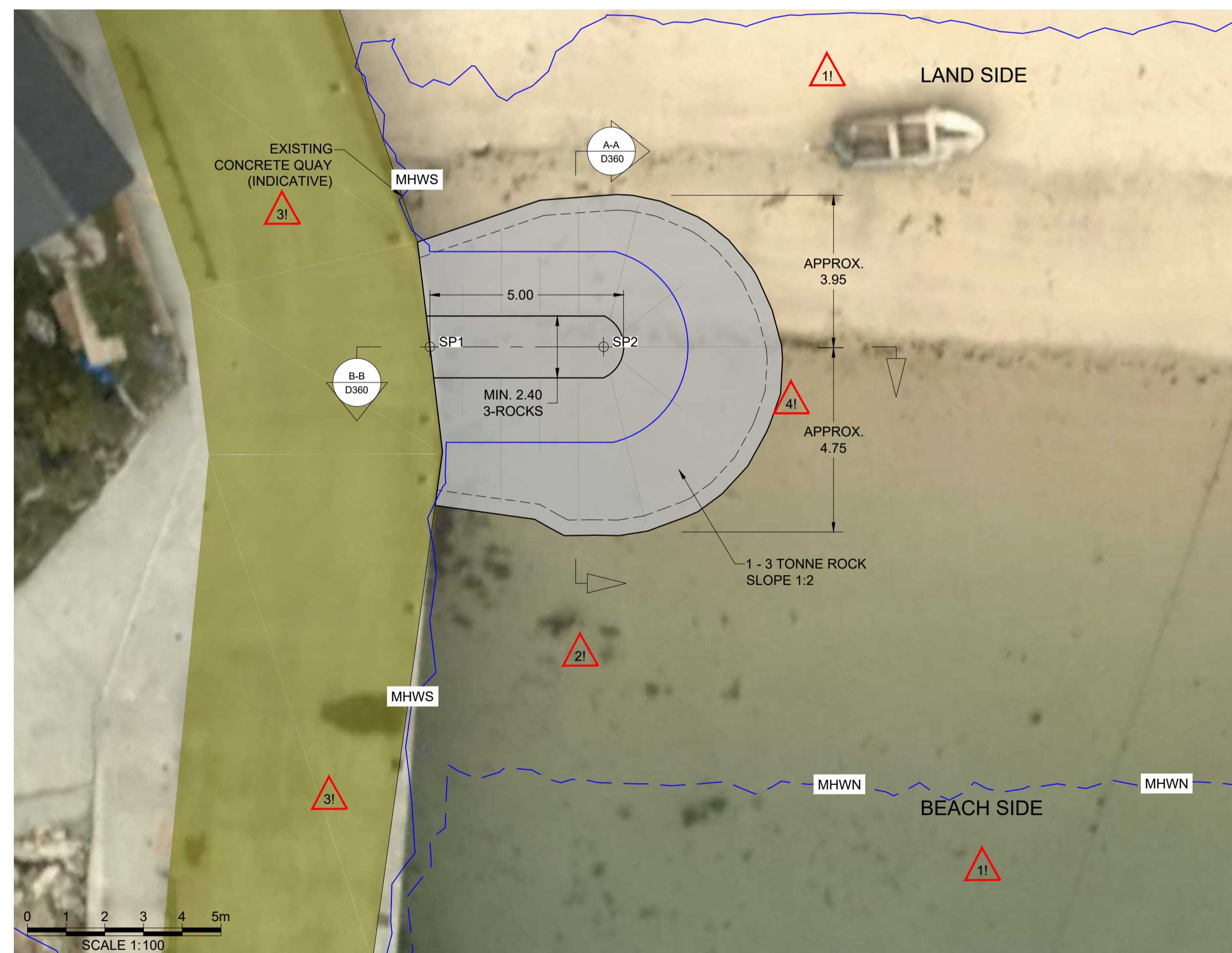
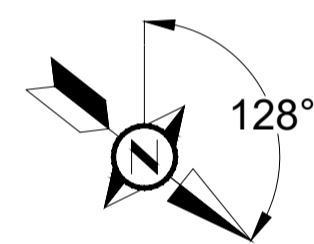

GROYNE LAYOUT
 (SCALE 1:100)

LOCATION PLAN:

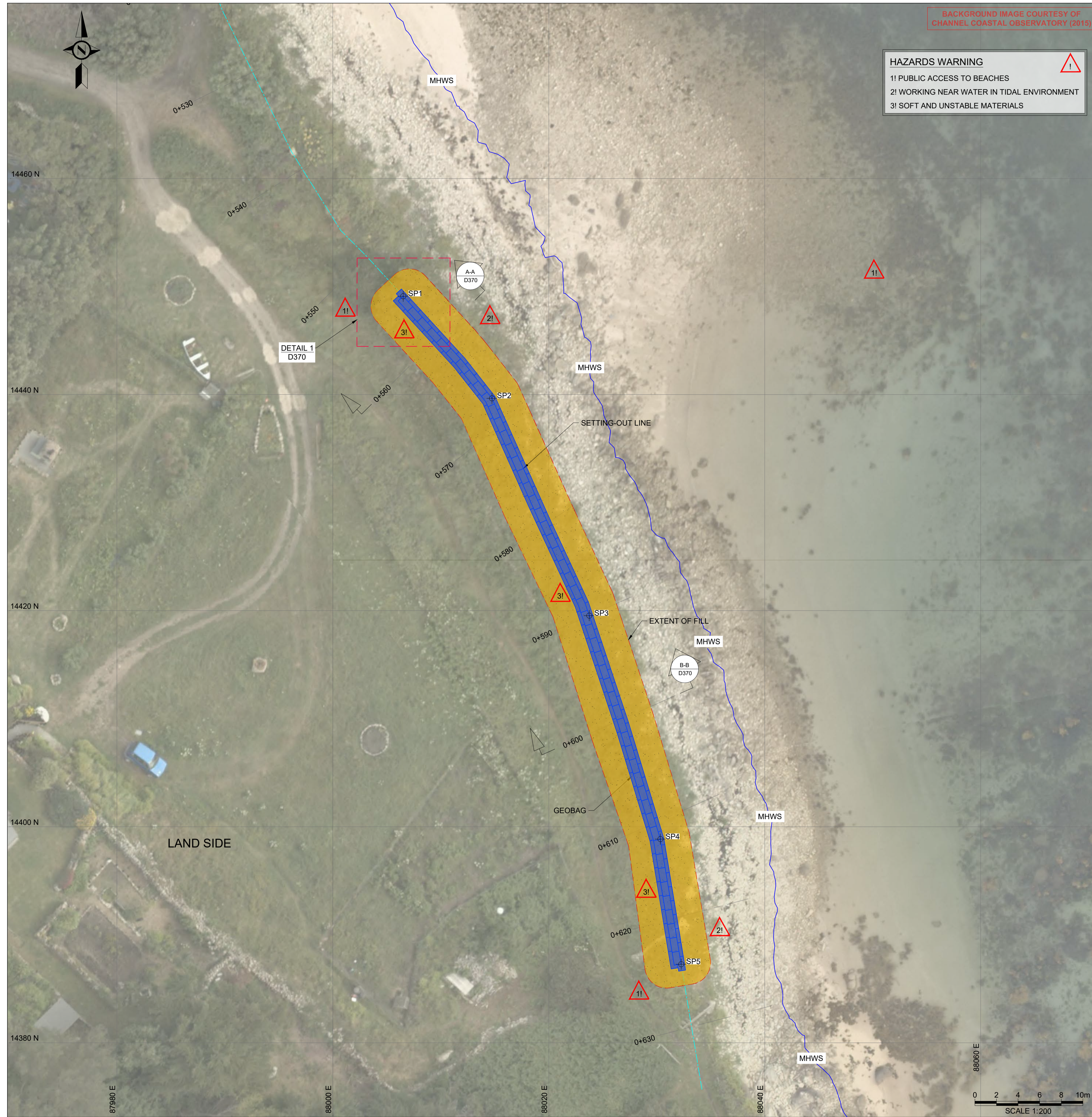
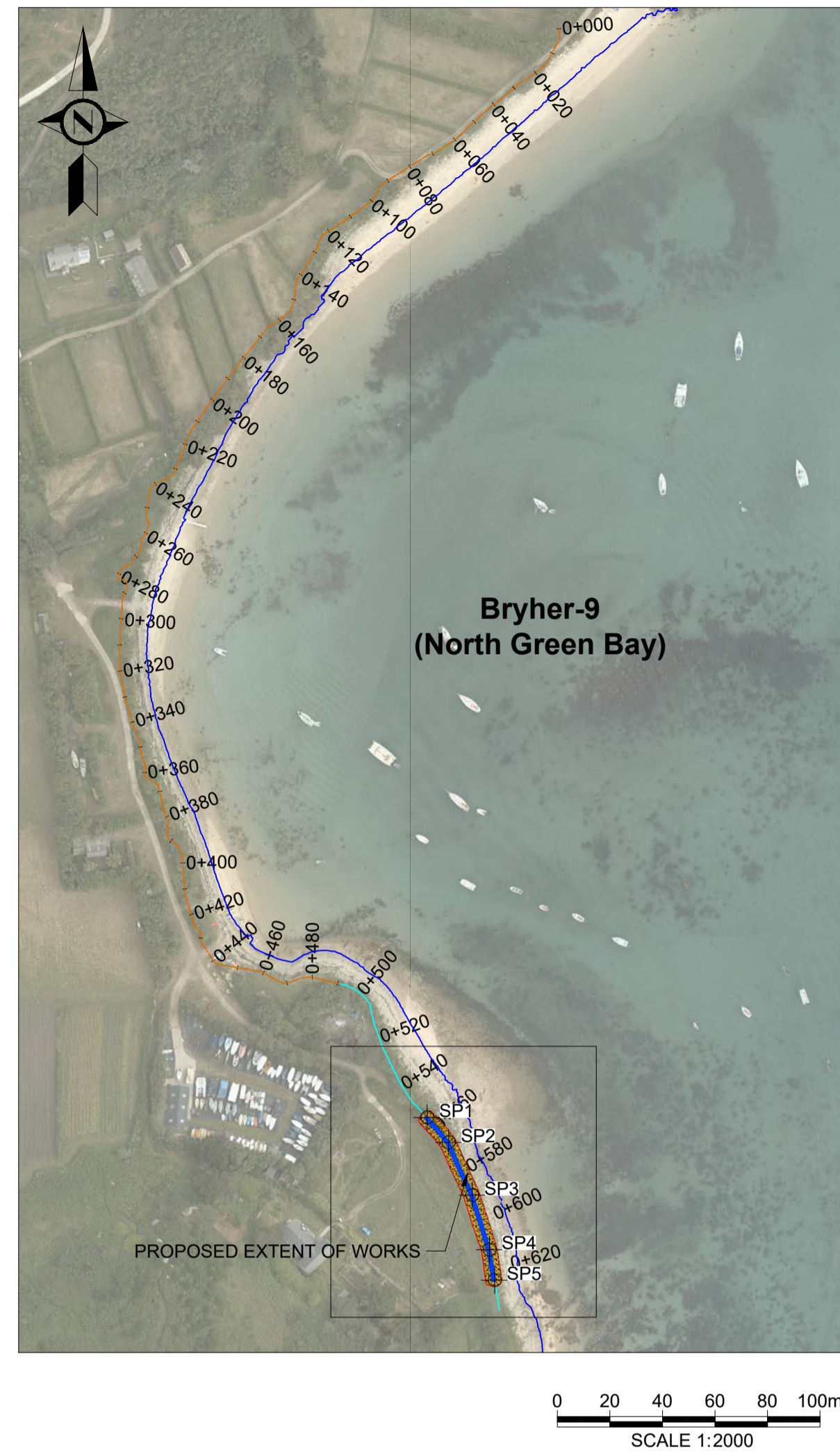

HAZARDS WARNING

- 1! PUBLIC ACCESS TO BEACHES
- 2! WORKING NEAR WATER IN TIDAL ENVIRONMENT
- 3! SOFT AND UNSTABLE MATERIALS

KEY PLAN:

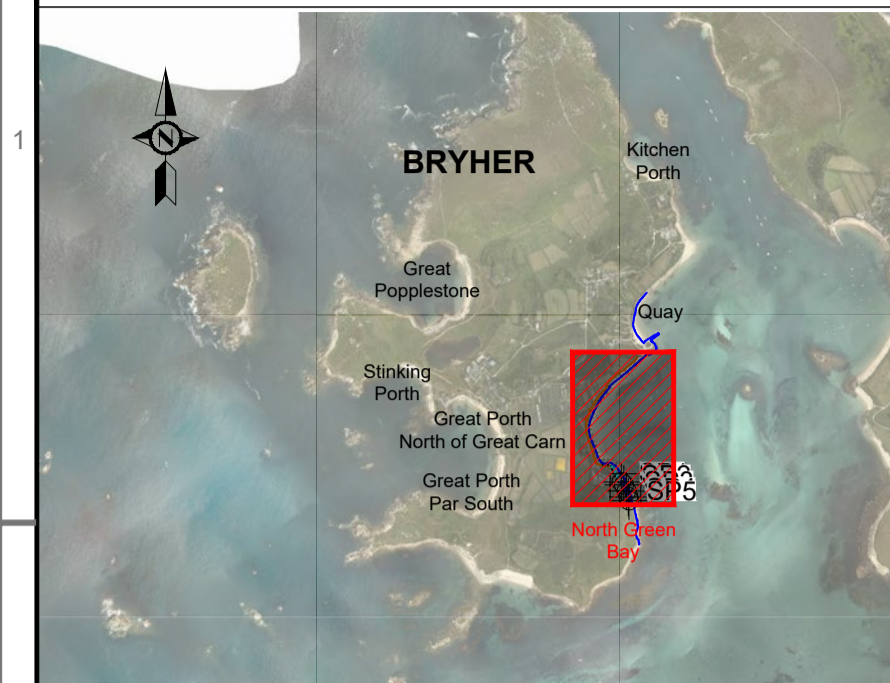

NOTES:

1. ALL DIMENSIONS ARE IN METRES UNLESS STATED OTHERWISE.
2. HORIZONTAL DATUM IS REFERENCED TO OSGB 1936 BRITISH NATIONAL GRID.
3. VERTICAL DATUM IS IN METRES, ORDNANCE DATUM.
4. SETTING OUT POINTS TO BE AGREED FOLLOWING DETAILED TOPOGRAPHIC SURVEYS.
5. ALL LEVELS TO BE CONFIRMED FOLLOWING ON SITE SURVEY.
6. CONTRACTOR TO CONFIRM DETAILS OF TIE INS TO EXISTING GROUND.
7. GEOBAG LINE TO BE CONFIRMED FOLLOWING SITE TOPOGRAPHIC SURVEY.
8. EXISTING TREES AND SHRUBS TO BE RETAINED WHERE POSSIBLE.
9. FOR GENERAL NOTES REFER TO DRAWING No. DKR6499-000-D102.
10. FOR TYPICAL SECTIONS REFER TO DRAWING No. DKR6499-210-D370.
11. SIGNAGE WARNING OF DANGER ON CLIMBING ON ROCK TO BE PROVIDED AS PER EMPLOYERS REQUIREMENTS.
12. RADII AND ADDITIONAL SETTING OUT POINTS ARE NOT INCLUDED DUE TO UNCERTAINTY ON LEVELS.

LEGEND:

- GEOBAG
- BACKFILL
- MHWS= 2.77 mOD

SP1	Easting	Northing	Elevation
SP1	88.0065	14.4491	5.050
SP2	88.0147	14.4397	5.050
SP3	88.0237	14.4195	5.050
SP4	88.0303	14.3989	5.050
SP5	88.0323	14.3873	5.050

01	ISSUED FOR REVIEW	PGU	AGC	AUO	11 JUL 22
REV	DRAWING STATUS	DRN	APPR	AUTH	DATE

CLIENT:

**THE COUNCIL OF
THE ISLES OF SCILLY**

MARINE CONSULTANT:

HR Wallingford
Howbery Park, Wallingford
Oxfordshire OX10 8BA
United Kingdom

Tel: +44(0)1491 835381
Fax: +44(0)1491 832233

PROJECT:

**ISLES OF SCILLY
DESIGN SERVICES FOR OFF ISLANDS
COASTAL EROSION DEFENCE AND
DUNE MANAGEMENT**

DRAWING TITLE:

**BRYHER-9 NORTH GREEN BAY
GENERAL ARRANGEMENT LAYOUT**

SCALE: AS SHOWN SHEET SIZE: A1

DRAWING No: DKR6499-210-D116 REV: 01

I:\work\local\projects\islands\dkr6499-210-D116 [02] General Arrangements-Bryher 9-North Green Bay_02.dwg PGU 08/07/22

HR Wallingford has prepared this document under the terms of the contract between them and their client, for the exclusive use of that client. HR Wallingford accepts no liability for any use of this document other than by their client and then only for the purposes for which it was prepared. No warranty is given for any third party data included in this document.

KEY PLAN:

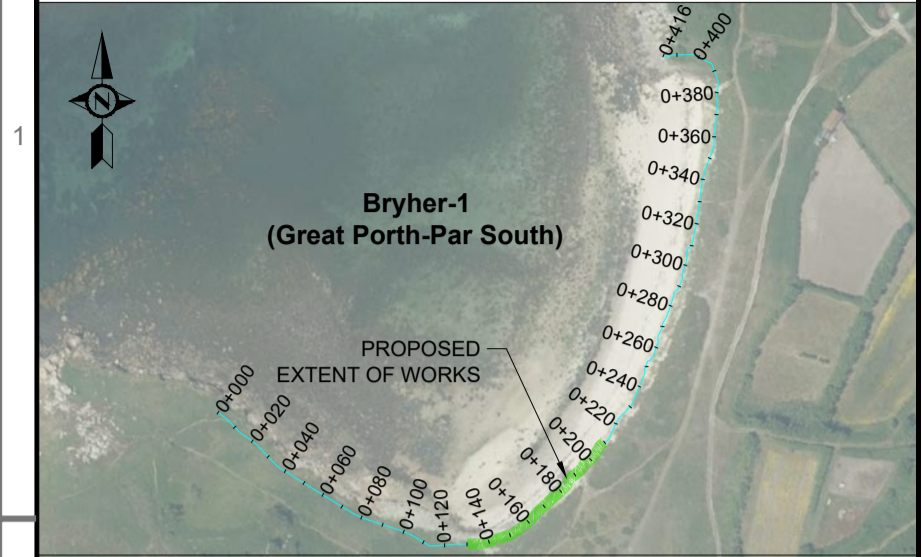

NOTES:

- ALL DIMENSIONS ARE IN METRES UNLESS STATED OTHERWISE.
- HORIZONTAL DATUM IS REFERENCED TO OSGB 1936 BRITISH NATIONAL GRID.
- VERTICAL DATUM IS IN METRES, ORDNANCE DATUM.
- SETTING OUT POINTS TO BE AGREED FOLLOWING DETAILED SURVEYS.
- ALL LEVELS TO BE CONFIRMED FOLLOWING ON SITE SURVEY.
- CONTRACTOR TO CONFIRM DETAILS OF TIE INS TO EXISTING GROUND.
- BACKGROUND IMAGE REPRODUCED FROM BING MAPS, © 2021 MICROSOFT.
- FOR GENERAL NOTES REFER TO DRAWING No. DKR6499-000-D102.
- FOR GENERAL ARRANGEMENT LAYOUT REFER TO DRAWING No. DKR6499-210-D110.
- SIGNAGE WARNING OF DANGER ON CLIMBING ON ROCK TO BE PROVIDED AS PER EMPLOYERS REQUIREMENTS.
- LARGE EXISTING ROCKS IN EXCESS OF 1 - 3T GRADE TO BE PLACED AS TOE.

HAZARDS WARNING

- 1! PUBLIC ACCESS TO BEACHES
- 2! WORKING NEAR WATER IN TIDAL ENVIRONMENT
- 3! SOFT AND UNSTABLE MATERIALS
- 4! LARGE ROCKS & VOIDS

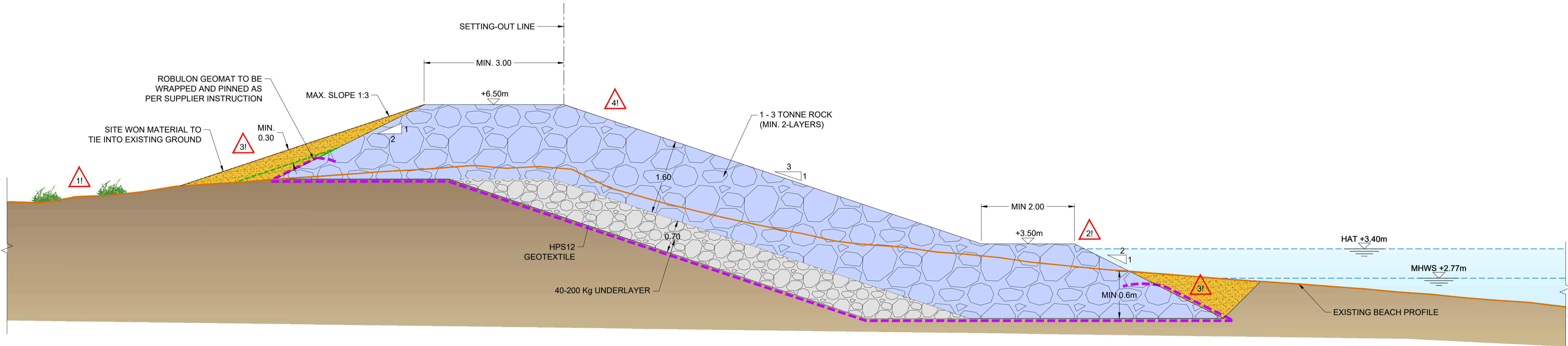

SECTION A-A
Ch.0+160

TIDE LEVELS	
mOD	
HAT	+3.40m
MHWS	+2.77m
MHWN	+1.44m
MLWN	-0.87m
MLWS	-2.18m
LAT	-2.82m



01	ISSUED FOR REVIEW	WST	AGC	AGC	23 AUG 22
REV	DRAWING STATUS	DRN.	APPR	AUTH.	DATE

CLIENT:
THE COUNCIL OF THE ISLES OF SCILLY

MARINE CONSULTANT:
HR Wallingford
Howbery Park, Wallingford
Oxfordshire OX10 8BA
United Kingdom
Tel: +44(0)1491 835381
Fax: +44(0)1491 832233
www.hrwallingford.com

PROJECT:
**ISLES OF SCILLY
DESIGN SERVICES FOR OFF ISLANDS
COASTAL EROSION DEFENCE AND
DUNE MANAGEMENT**

DRAWING TITLE:
**BRYHER 1
GREAT PORTH-PAR SOUTH
TYPICAL SECTION**

SCALE: 1:50 SHEET SIZE: A1

DRAWING No: DKR6499-210-D310 REV: 01

I:\hrw\uk\local\projects\live\dkr6499\5\deliverables\drawings\Current Drawings\DKR6499-210-D310 [01]_Bryher 1-Great Porth-Par South-Typical Section_01_00.dwg
 WST
 22/08/22

HR Wallingford has prepared this document under the terms of the contract between them and their client, for the exclusive use of that client. HR Wallingford accepts no liability for any use of this document other than by their client and then only for the purposes for which it was prepared. No warranty is given for any third party data included in this document.

NOTES:

1. ALL DIMENSIONS ARE IN METRES UNLESS STATED OTHERWISE.
2. HORIZONTAL DATUM IS REFERENCED TO OSGB 1936 BRITISH NATIONAL GRID.
3. VERTICAL DATUM IS IN METRES, ORDNANCE DATUM.
4. SETTING OUT POINTS TO BE AGREED FOLLOWING DETAILED SURVEYS.
5. ALL LEVELS TO BE CONFIRMED FOLLOWING ON SITE SURVEY.
6. DEMOUNTABLE FLOOD BARRIER TO BE AS SUPPLIED BY FLOOD CONTROL INTERNATIONAL OR SIMILAR APPROVED.
7. FOR GENERAL NOTES REFER TO DRAWING No. DKR6499-000-D102.
8. FOR SITE 2/3B GENERAL ARRANGEMENT REFER TO DRAWING DKR6499/210/D111.
9. FOR GENERAL FLOOD GATE DETAILS REFER TO DRAWING DKR6499/210/D322.
10. FOR CONCRETE DETAILS REFER TO DRAWINGS DKR6499/210/D323 AND DKR6499/210/D324.
11. LIFTING POINTS TO BE CUT AND FILLED WITH HIGH STRENGTH GROUT.
12. EXPANSION JOINT WITH SILICONE SEALANT TO BE PROVIDED BETWEEN SLAB AND MASS CONCRETE BLOCKS.

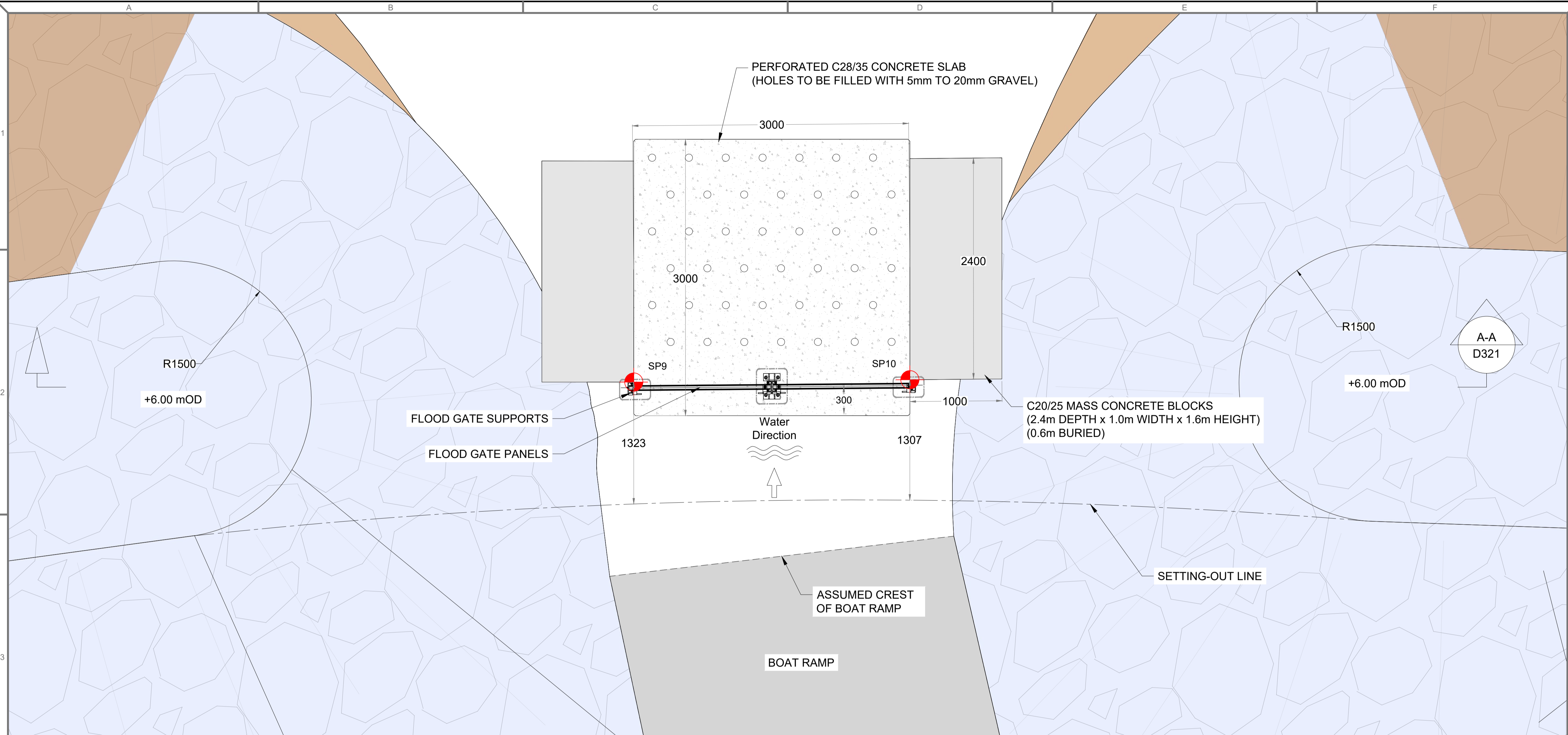

PLAN VIEW:DETAIL 1
SCALE: 1:25

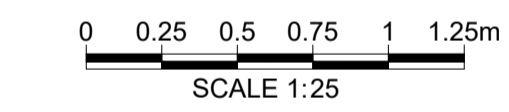

SP	Easting	Northing	Elevation
SP9	87.5434	14.7080	4.750
SP10	87.5459	14.7061	4.750

TIDE LEVELS	
mOD	
HAT	+3.40m
MHWS	+2.77m
MHWN	+1.44m
MLWN	-0.87m
MLWS	-2.18m
LAT	-2.82m

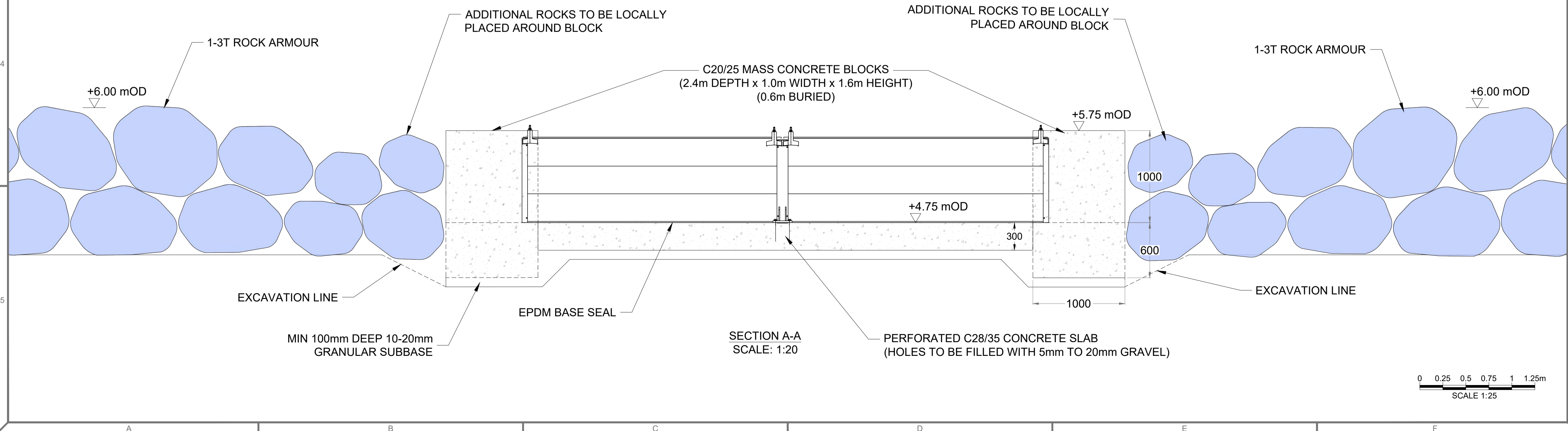

SECTION A-A
SCALE: 1:20

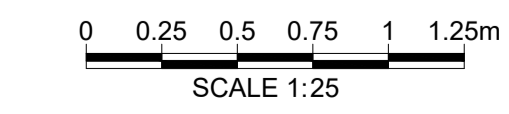

01	ISSUED FOR REVIEW	PGU	MGO	AGC	05 AUG 22
REV	DRAWING STATUS	DRN	APPR	AUTH	DATE

CLIENT:

THE COUNCIL OF THE ISLES OF SCILLY

MARINE CONSULTANT:

HR Wallingford
 Howbery Park, Wallingford
 Oxfordshire OX10 8BA
 United Kingdom
 Tel: +44(0)1491 835381
 Fax: +44(0)1491 832233
www.hrwallingford.com

PROJECT:
**ISLES OF SCILLY
 DESIGN SERVICES FOR OFF ISLANDS
 COASTAL EROSION DEFENCE AND
 DUNE MANAGEMENT**

DRAWING TITLE:
**BRYHER 2/3B
 GREAT PORTH NORTH
 DEMOUNTABLE FLOOD BARRIER
 GENERAL ARRANGEMENT**

SCALE:
AS SHOWN SHEET SIZE:
A1

DRAWING No:
DKR6499-210-D321 REV:
01

I:\hr-wuk-local\projects\isles\dkr6499\5_deliverables\drawings\Current\Drawings\DKR6499-210-D321_Great Porth North Flood Barrier Concrete Details_01.dwg
 PGU
 05/08/22

HR Wallingford has prepared this document under the terms of the contract between them and their client, for the exclusive use of that client.
 HR Wallingford accepts no liability for any use of this document other than by their client and then only for the purposes for which it was prepared. No warranty is given for any third party data included in this document.

NOTES:

1. ALL DIMENSIONS ARE IN METRES UNLESS STATED OTHERWISE.
2. HORIZONTAL DATUM IS REFERENCED TO OSGB 1936 BRITISH NATIONAL GRID.
3. VERTICAL DATUM IS IN METRES, ORDNANCE DATUM.
4. SETTING OUT POINTS TO BE AGREED FOLLOWING DETAILED SURVEYS.
5. ALL LEVELS TO BE CONFIRMED FOLLOWING ON SITE SURVEY.
6. DETAILS OF DEMOUNTABLE FLOOD BARRIER ARE INDICATIVE ONLY AND SUBJECT TO SUPPLIERS DETAILS AND SHOP DRAWINGS.
7. DEMOUNTABLE FLOOD BARRIER TO BE AS SUPPLIED BY FLOOD CONTROL INTERNATIONAL OR SIMILAR APPROVED.
8. ANCHOR BOLTS FOR IMMEDIATE SUPPORT TO BE POST FIXED INTO RC BASE SLAB. DETAIL TO BE CONFIRMED WITH ENGINEER PRIOR TO INSTALLATION.
9. FOR GENERAL NOTES REFER TO DRAWING No. DKR6499-000-D102.
10. FOR GENERAL ARRANGMENT LAYOUT OF FLOOD GATE REFER TO DRAWING DKR6499/210/D321.
11. FOR SITE 2/3B GENERAL ARRANGEMENT REFER TO DRAWING DKR6499/210/D111.
12. FOR CONCRETE DETAILS REFER TO DRAWINGS DKR6499/210/D323 AND DKR6499/210/D324.
13. ALL CRITICAL ARRANGEMENTS AND DIMENSIONS SHOWN SHALL BE VERIFIED BY THE CONTRACTOR ON SITE BEFORE WORK COMMENCES. DRAWINGS SHALL NOT BE SCALED FOR DIMENSIONS.
14. ANY DISCREPANCIES EITHER BETWEEN THE MAIN WRITTEN DIMENSIONS AND THE SITE DIMENSIONS OR BETWEEN THIS DRAWING AND OTHER SUPPLIERS DRAWINGS SHOULD BE BROUGHT TO THE ATTENTION OF THE ENGINEER.

MASS CONCRETE BLOCKS
 (2.4m DEPTH x 1.0m WIDTH x 1.6m HEIGHT)
 (0.6m BURIED)

GALVANISED RECESS MOUNT END SUPPORTS FIXED USING HILTI HUS-CR 10X85, POWDER COATED RAL1016 (SULFUR YELLOW)

PLAN VIEW
 (SCALE 1:20)

ELEVATION VIEW
 (SCALE 1:20)

TIDE LEVELS	
mOD	
HAT	+3.40m
MHWS	+2.77m
MHWN	+1.44m
MLWN	-0.87m
MLWS	-2.18m
LAT	-2.82m

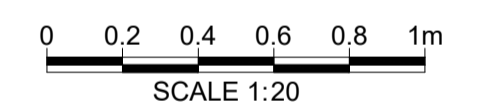

01	ISSUED FOR REVIEW	PGU	MGO	AGC	05 AUG 22
REV	DRAWING STATUS	DRN	APPR	AUTH	DATE

CLIENT:

THE COUNCIL OF THE ISLES OF SCILLY

MARINE CONSULTANT:

HR Wallingford
 Howbery Park, Wallingford
 Oxfordshire OX10 8BA
 United Kingdom
 Tel: +44(0)1491 835381
 Fax: +44(0)1491 832233
www.hrwallingford.com

PROJECT: **ISLES OF SCILLY
 DESIGN SERVICES FOR OFF ISLANDS
 COASTAL EROSION DEFENCE AND
 DUNE MANAGEMENT**

DRAWING TITLE: **BRYHER 2/3B
 GREAT PORTH NORTH
 DEMOUNTABLE FLOOD BARRIER
 DETAIL**

SCALE: **JUST AS SHOWN** SHEET SIZE: **A1**

DRAWING No: **DKR6499-210-D322** REV: **01**

I:\hrw\uk\local\projects\live\dkr6499-210-D322_Great Porth North Demountable Flood Barrier_01.dwg
 PGU
 05/08/22

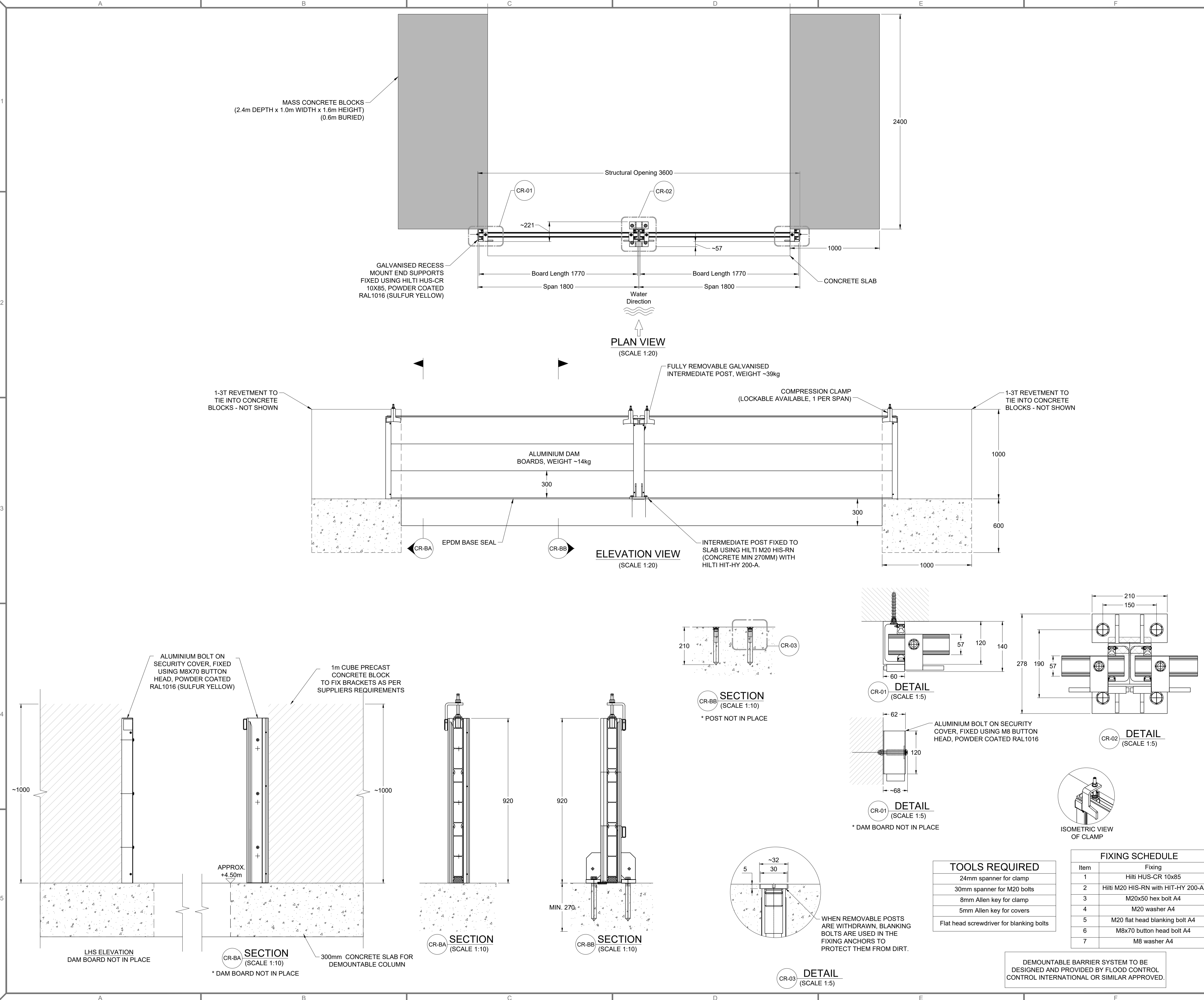

SECTION (SCALE 1:10)
 * POST NOT IN PLACE

DETAIL (SCALE 1:5)

DETAIL (SCALE 1:5)

DETAIL (SCALE 1:5)
 * DAM BOARD NOT IN PLACE

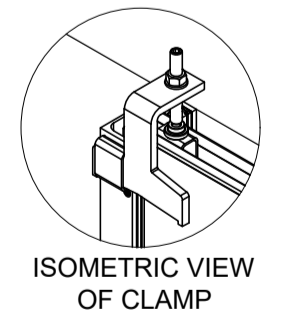

TOOLS REQUIRED

24mm spanner for clamp
30mm spanner for M20 bolts
8mm Allen key for clamp
5mm Allen key for covers
Flat head screwdriver for blanking bolts

FIXING SCHEDULE

Item	Fixing
1	Hilti HUS-CR 10x85
2	Hilti M20 HIS-RN with HIT-HY 200-A
3	M20x50 hex bolt A4
4	M20 washer A4
5	M20 flat head blanking bolt A4
6	M8x70 button head bolt A4
7	M8 washer A4

WHEN REMOVABLE POSTS ARE WITHDRAWN, BLANKING BOLTS ARE USED IN THE FIXING ANCHORS TO PROTECT THEM FROM DIRT.

DEMOUNTABLE BARRIER SYSTEM TO BE DESIGNED AND PROVIDED BY FLOOD CONTROL CONTROL INTERNATIONAL OR SIMILAR APPROVED.

HR Wallingford has prepared this document under the terms of the contract between them and their client, for the exclusive use of that client. HR Wallingford accepts no liability for any use of this document other than by their client and then only for the purposes for which it was prepared. No warranty is given for any third party data included in this document.

NOTES:

1. ALL DIMENSIONS ARE IN MILLIMETRES UNLESS STATED OTHERWISE.
2. CONCRETE TO COMPLY WITH THE REQUIREMENTS OF THE PROJECT CONSTRUCTION SPECIFICATION (DKR6499-RT010).
3. CONCRETE TO COMPLY WITH THE REQUIREMENTS OF BS8500-1:2015+A1:2016.
4. MASS CONCRETE BLOCKS TO BE TYPE C25/30 (25N/mm² CUBE STRENGTH), 20mm MAX. AGGREGATE SIZE, MAX. W/C RATIO 0.55, MIN. CEMENT CONTENT 300kg/m³, CEMENT TYPE IIB-V, IIB-V+SR, IIIA, OR IIIA+SR IN ACCORDANCE WITH BS8500-1:2015+A1:2016.
5. PERFORATED RC SLAB TO BE TYPE C28/30 (28N/mm² CUBE STRENGTH), 20MM MAX. AGGREGATE SIZE, MAX. W/C RATIO 0.45, CEMENT TYPE IIB-V OR IIBB IN ACCORDANCE WITH BS8500-1:2015+A1:2016.
6. MASS CONCRETE EXPOSURE CLASS XAS.
7. REINFORCED CONCRETE EXPOSURE CLASS XS3.
8. FOR GENERAL NOTES REFER TO DRAWING No. DKR6499-000-D102.
9. FOR SITE 2/3B GENERAL ARRANGEMENT REFER TO DRAWING DKR6499/210/D111.
10. FOR GENERAL FLOOD GATE DETAILS REFER TO DRAWING DKR6499/210/D322.
11. FOR CONCRETE SLAB REINFORCEMENT DETAILS REFER TO DRAWING DKR6499/210/D324.
12. LIFTING POINTS TO BE CUT AND FILLED WITH HIGH STRENGTH GROUT.
13. EXPANSION JOINT WITH SILICONE SEALANT TO BE PROVIDED BETWEEN SLAB AND MASS CONCRETE BLOCKS.

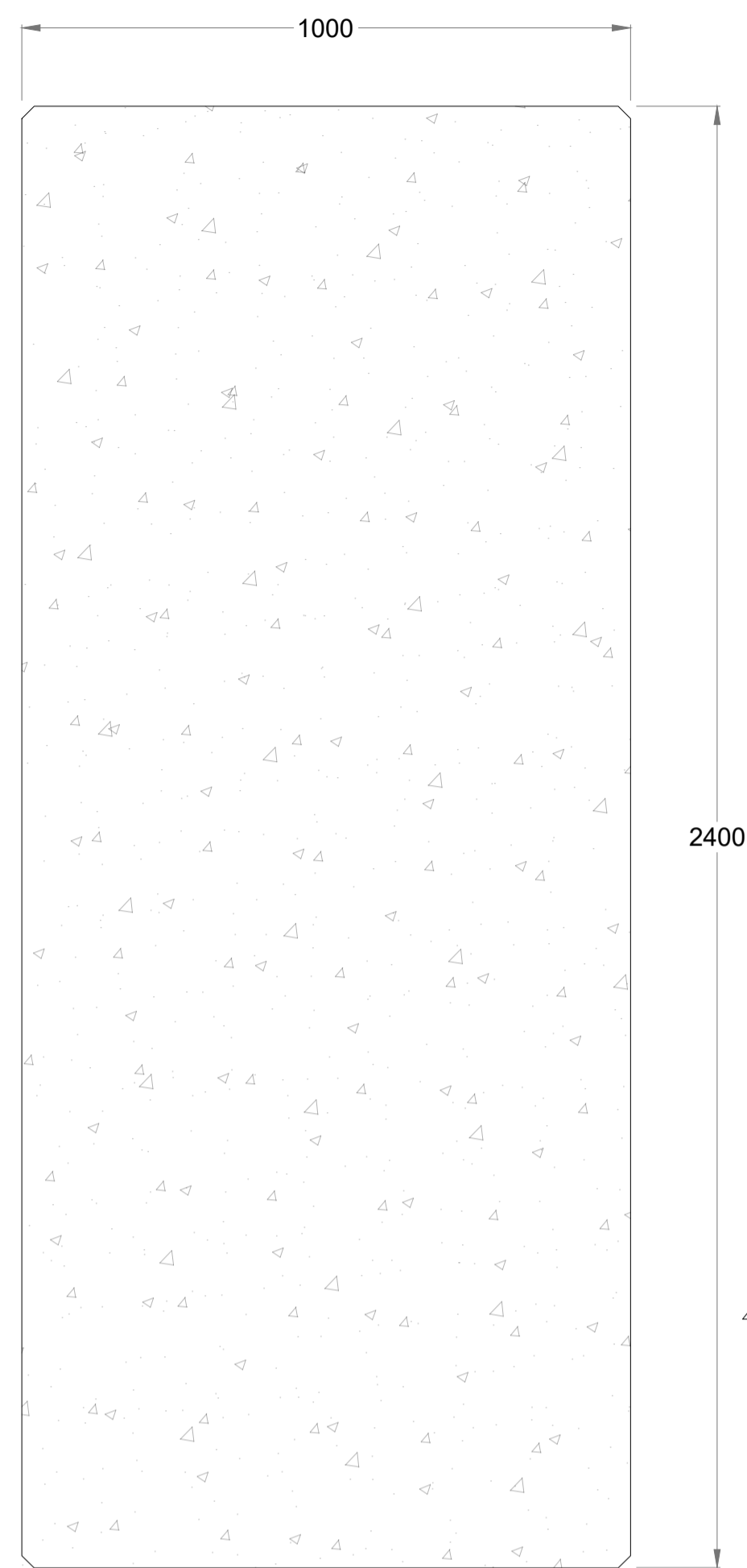

MASS CONCRETE BLOCK (2 NO.)
SCALE: 1:10

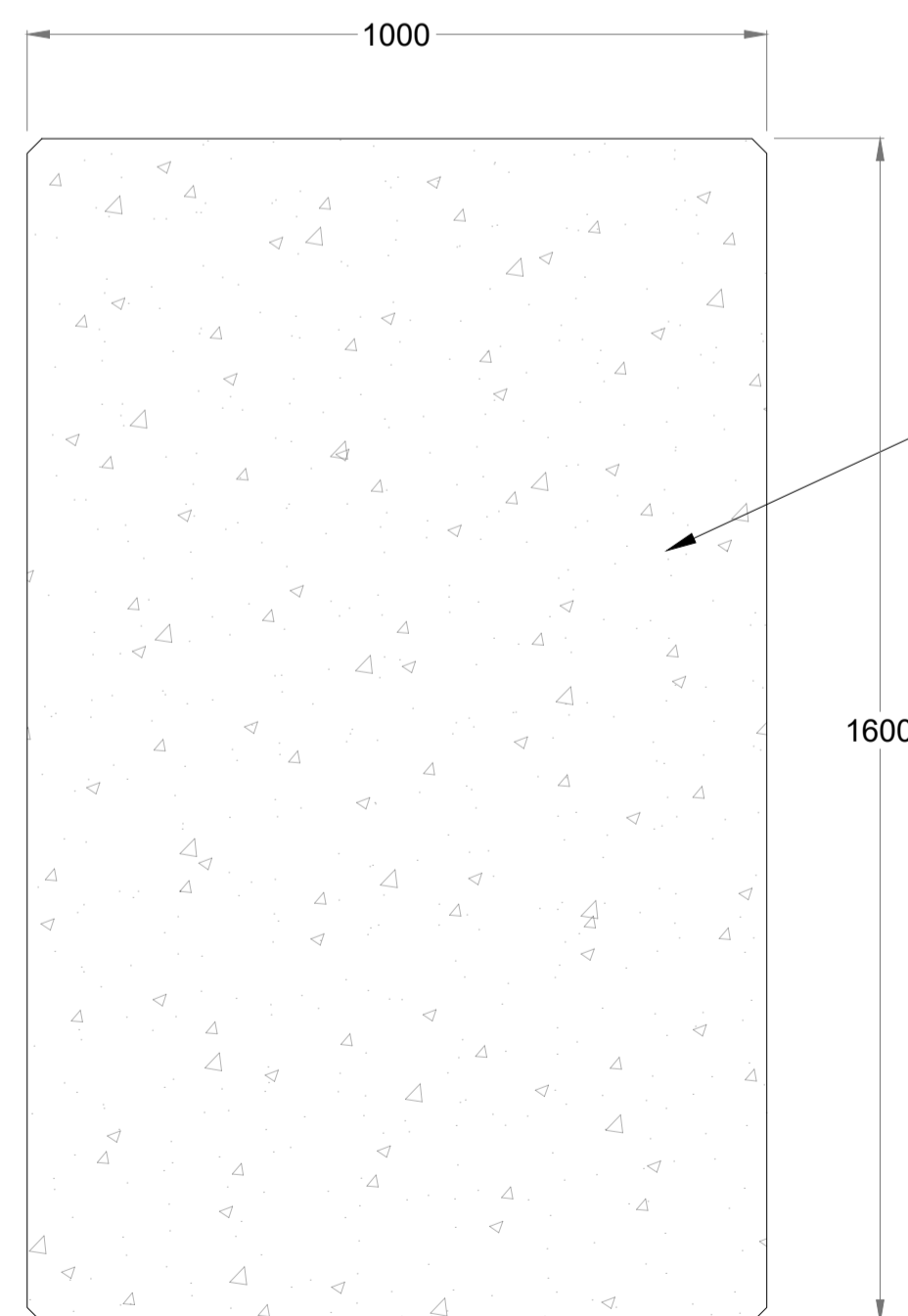

C20/25 MASS CONCRETE BLOCK
(2.4m DEPTH x 1.0m WIDTH x 1.6m HEIGHT)
SEE NOTES 4 AND 6

SECTION B-B
SCALE: 1:10

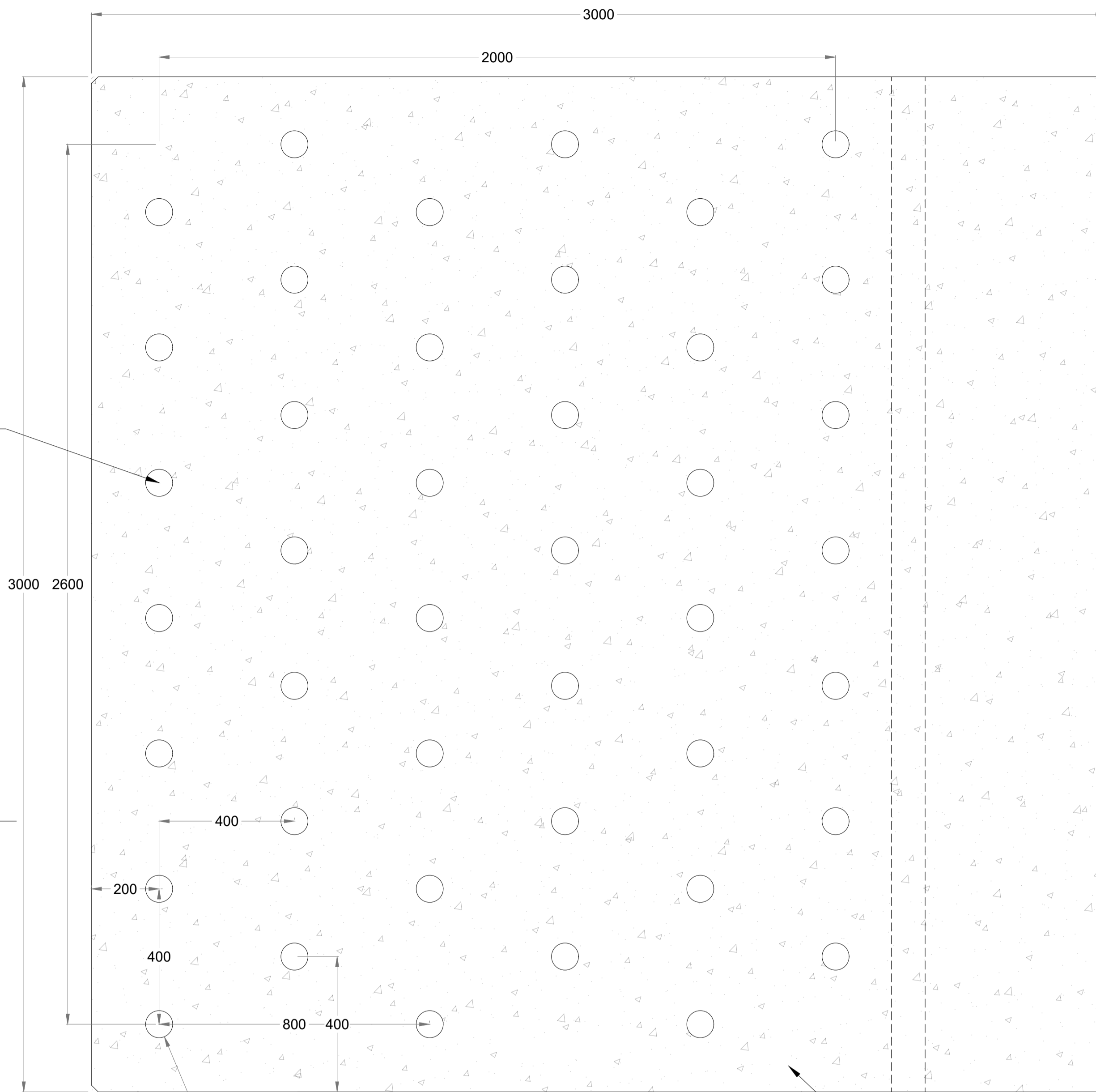

PERFORATED REINFORCED CONCRETE SLAB (1 NO.)
SCALE: 1:10

C28/35 CONCRETE SLAB
SEE NOTES 5 AND 7

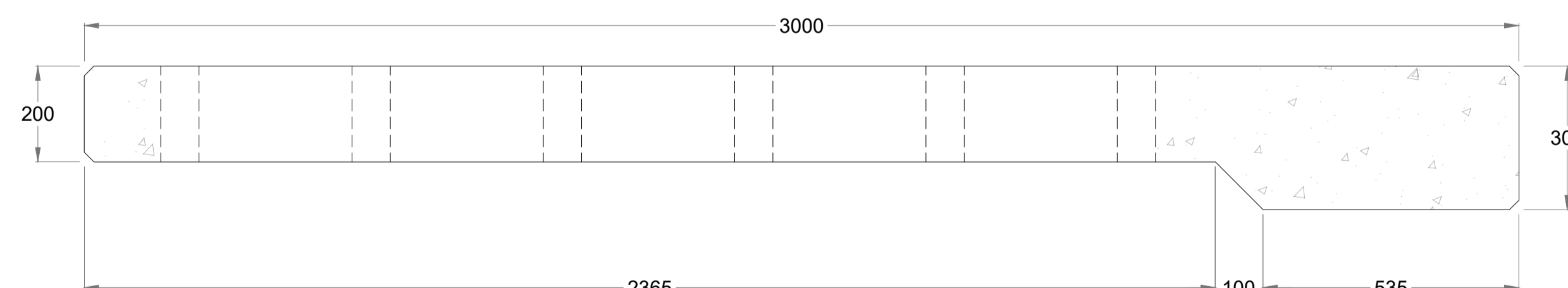

SECTION A-A
SCALE: 1:10

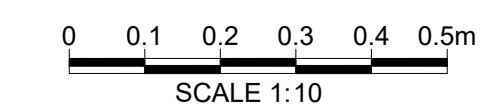

01	ISSUED FOR REVIEW	WST	MGO	AGC	05 AUG 22
REV	DRAWING STATUS	DRN	APPR	AUTH	DATE

CLIENT:

**THE COUNCIL OF
THE ISLES OF SCILLY**

MARINE CONSULTANT:



HR Wallingford
Howbery Park, Wallingford
Oxfordshire OX10 8BA
United Kingdom
Tel: +44(0)1491 835381
Fax: +44(0)1491 832233

PROJECT:
**ISLES OF SCILLY
DESIGN SERVICES FOR OFF ISLANDS
COASTAL EROSION DEFENCE AND
DUNE MANAGEMENT**

DRAWING TITLE:
**BRYHER 2/3B
GREAT PORTH NORTH
CONCRETE STRUCTURAL DETAILS**

SCALE:
1:10

SHEET SIZE:
A1

DRAWING No:
DKR6499-210-D323

REV:
01

HR Wallingford has prepared this document under the terms of the contract between them and their client, for the exclusive use of that client. HR Wallingford accepts no liability for any use of this document other than by their client and then only for the purposes for which it was prepared. No warranty is given for any third party data included in this document.

NOTES:

- ALL DIMENSIONS ARE IN MILLIMETRES UNLESS OTHERWISE STATED.
 - REINFORCEMENT IDENTIFICATION:
 - 9H12 - 01 - 150 REBAR SPACING
 - BAR MARK BAR MARK
 - REBAR DIAMETER REBAR DIAMETER
 - REBAR TYPE REBAR TYPE
 - QUANTITY OF REBARS QUANTITY OF REBARS
 - NOMINAL COVER TO OUTER LAYER OF REINFORCEMENT TO BE NOT LESS THAN 60mm ($\Delta c = 10\text{mm}$).
 - REINFORCEMENT TO BE GRADE H (AS DEFINED IN BS8666:2005).
 - REINFORCEMENT TO COMPLY WITH THE REQUIREMENTS OF THE PROJECT CONSTRUCTION SPECIFICATION (DKR6499-RT010).
 - ALL CRANKS TO BE AT 1V:10H.
 - FOR GENERAL NOTES REFER TO DRAWING DKR6499/000/D102.
 - FOR SITE 2/3B GENERAL ARRANGEMENT REFER TO DRAWING DKR6499/210/D111.
 - FOR REINFORCED CONCRETE SLAB STRUCTURAL DETAILS REFER TO DRAWING DKR6499/210/D323.
 - ABBREVIATIONS:
 - T TOP
 - T1 TOP OUTER LAYER
 - T2 TOP SECOND LAYER
 - B2 BOTTOM SECOND LAYER
 - B1 BOTTOM OUTER LAYER
 - B BOTTOM
 - EF EACH FACE
 - NF NEAR FACE
 - FF FAR FACE
 - AB ALTERNATE BAR
 - ABR ALTERNATE BARS REVERSED
 - STGD STAGGERED
- NUMBER OF BARS PLACED TOGETHER
IN 3's
IN 2's

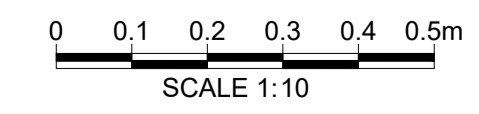
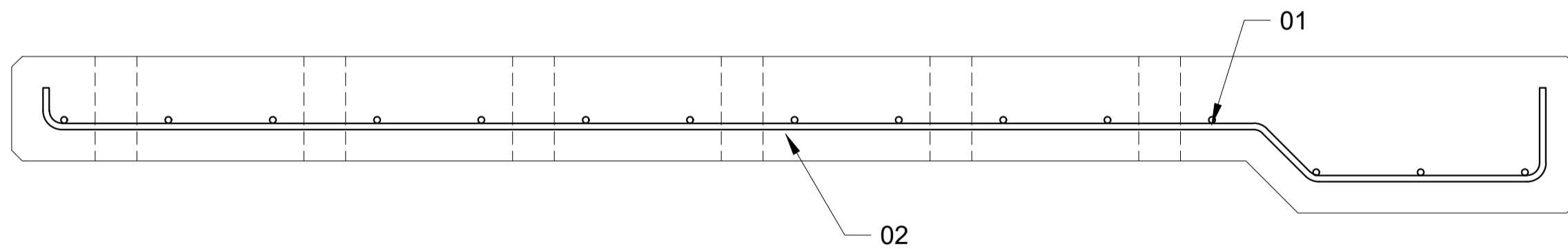
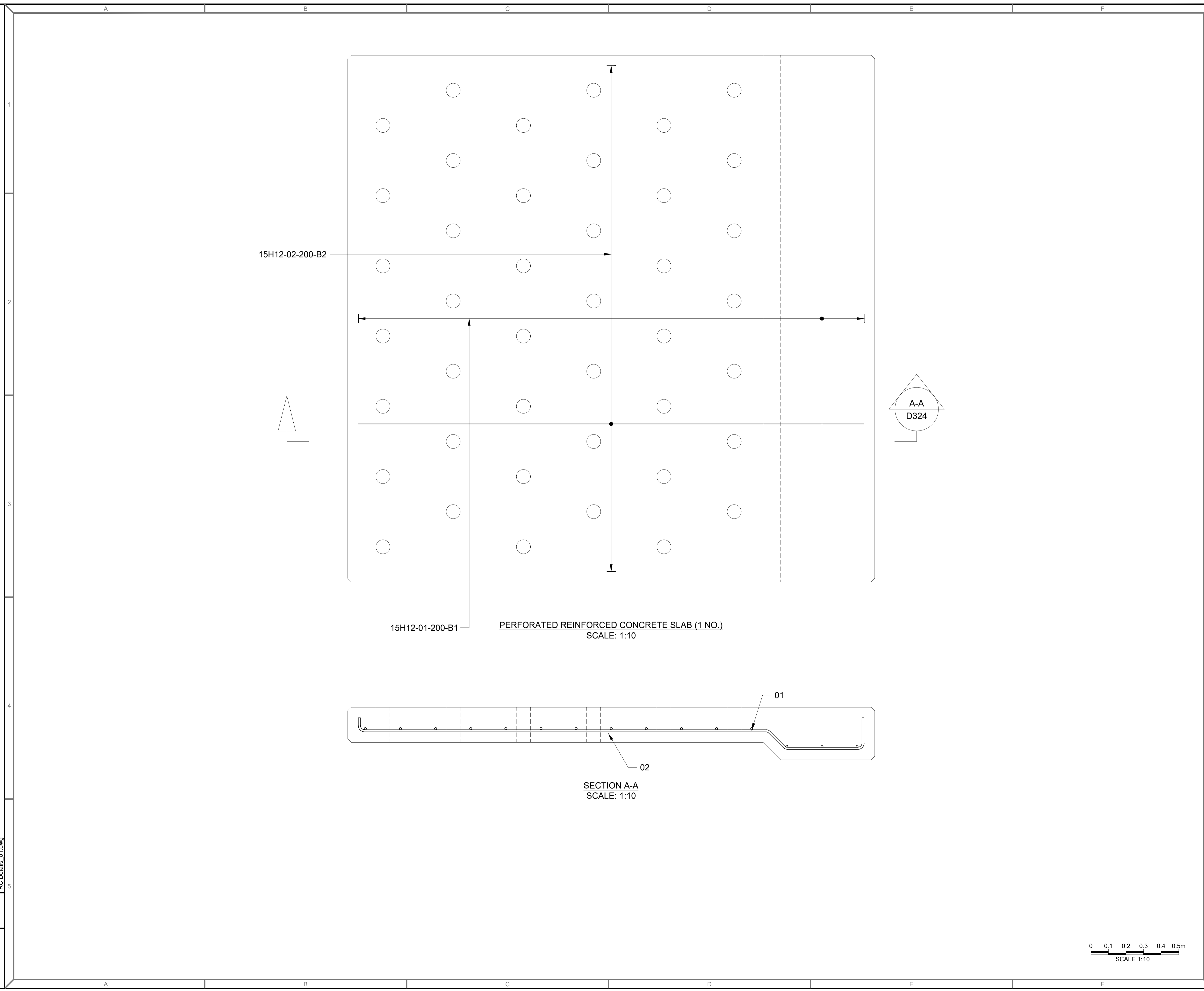

01	ISSUED FOR REVIEW	WST	MGO	AGC	05 AUG 22
REV	DRAWING STATUS	DRN.	APPR	AUTH.	DATE

CLIENT:
THE COUNCIL OF THE ISLES OF SCILLY

MARINE CONSULTANT:

HR Wallingford
 Howbery Park, Wallingford
 Oxfordshire OX10 8BA
 United Kingdom
 Tel: +44(0)1491 835381
 Fax: +44(0)1491 832233
www.hrwallingford.com

PROJECT:
**ISLES OF SCILLY
DESIGN SERVICES FOR OFF ISLANDS
COASTAL EROSION DEFENCE AND
DUNE MANAGEMENT**

DRAWING TITLE:
**BRYHER 2/3B
GREAT PORTH NORTH
REINFORCED CONCRETE SLAB
REINFORCEMENT DETAILS**

SCALE: 1:10 SHEET SIZE: A1

DRAWING No: DKR6499-210-D324 REV: 01

I:\work\local\projects\live\dkr6499\5_deliverables\drawings\Current Drawings\DKR6499-210-D324 [01]_Great Porth North Concrete Slab
 RC Details_01.dwg
 WST
 05/08/22

HR Wallingford has prepared this document under the terms of the contract between them and their client, for the exclusive use of that client. HR Wallingford accepts no liability for any use of this document other than by their client and then only for the purposes for which it was prepared. No warranty is given for any third party data included in this document.

KEY PLAN:

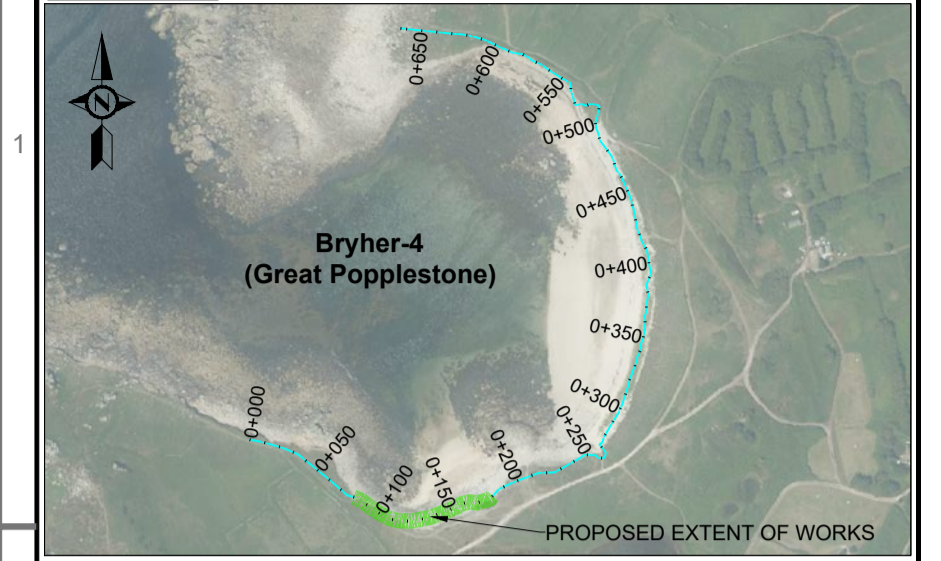

NOTES:

1. ALL DIMENSIONS ARE IN METRES UNLESS STATED OTHERWISE.
2. HORIZONTAL DATUM IS REFERENCED TO OSGB 1936 BRITISH NATIONAL GRID.
3. VERTICAL DATUM IS IN METRES, ORDNANCE DATUM.
4. SETTING OUT POINTS TO BE AGREED FOLLOWING DETAILED TOPOGRAPHIC SURVEYS SURVEYS.
5. ALL LEVELS TO BE CONFIRMED FOLLOWING ON SITE SURVEY.
6. CONTRACTOR TO CONFIRM DETAILS OF THE INS TO EXISTING GROUND.
7. EXISTING WALL SECTIONS SHOWN IS ILLUSTRATIVE OF A FIXED STRUCTURE ONLY.
8. FOR GENERAL NOTES REFER TO DRAWING No. DKR6499-000-D102.
9. FOR GENERAL ARRANGEMENT LAYOUT REFER TO DRAWING No. DKR6499-210-D113.
10. SIGNAGE WARNING OF DANGER ON CLIMBING ON ROCK TO BE PROVIDED AS PER EMPLOYERS REQUIREMENTS.
11. TYPICAL EXISTING PROFILES SHOWN IN SECTION A-A IS AT CHAINAGE 100 AND SECTION B-B IS AT CHAINAGE 160.

TIDE LEVELS	
mOD	
HAT	+3.40m
MHWS	+2.77m
MHWN	+1.44m
MLWN	-0.87m
MLWS	-2.18m
LAT	-2.82m

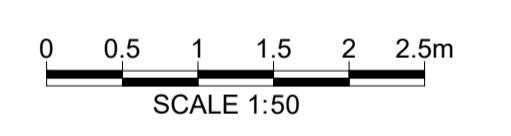

01	ISSUED FOR REVIEW	PGU	AGC	AUO	11 JUL 22
REV	DRAWING STATUS	DRN	APPR	AUTH.	DATE

CLIENT:
THE COUNCIL OF THE ISLES OF SCILLY

MARINE CONSULTANT:
HR Wallingford
Howbery Park, Wallingford
Oxfordshire OX10 8BA
United Kingdom
Tel: +44(0)1491 835381
Fax: +44(0)1491 832233

PROJECT:
**ISLES OF SCILLY
DESIGN SERVICES FOR OFF ISLANDS
COASTAL EROSION DEFENCE AND
DUNE MANAGEMENT**

DRAWING TITLE:
**BRYHER 4 - GREAT POPPLESTONE
TYPICAL SECTIONS**

SCALE: 1:50 SHEET SIZE: A1

DRAWING No: DKR6499-210-D340 REV: 01

HAZARDS WARNING

1! PUBLIC ACCESS TO BEACHES
2! WORKING NEAR WATER IN TIDAL ENVIRONMENT
3! UNKNOWN DETAIL OF EXISTING WALL
4! LARGE ROCKS & VOIDS

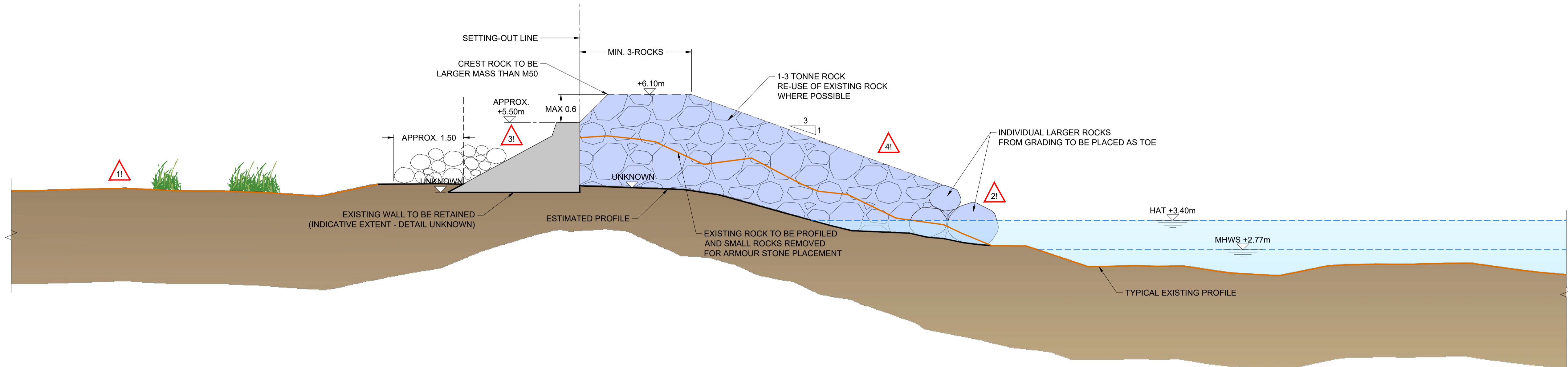

SECTION A-A
Ch.0+100

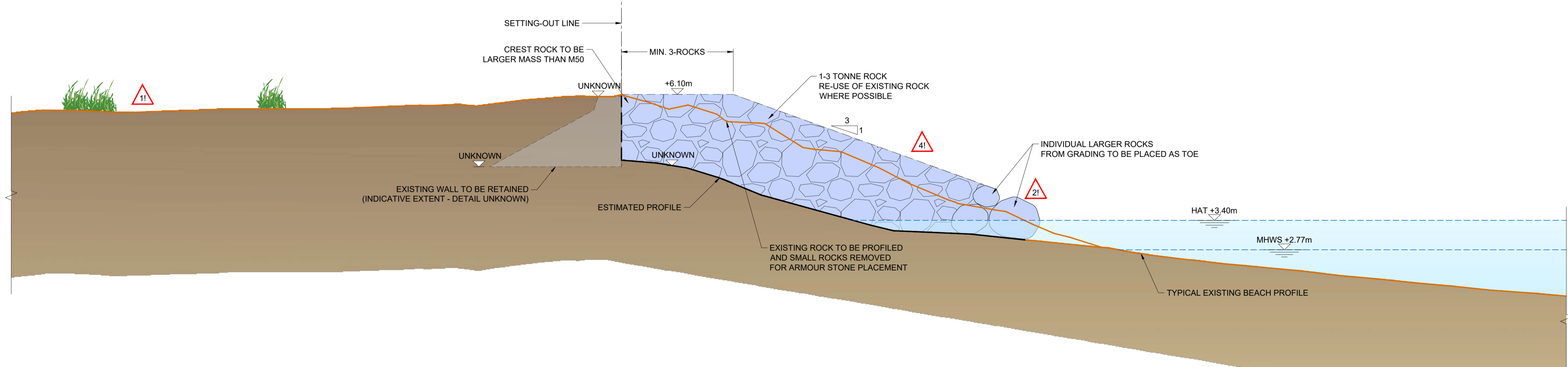

SECTION B-B
Ch.0+160

I:\work\local\projects\live\dkr6499-210-D340\021_Bryher 4-Great Popplestone-Typical Section_01.dwg
 PGU
 08/07/22

HR Wallingford has prepared this document under the terms of the contract between them and their client, for the exclusive use of that client. HR Wallingford accepts no liability for any use of this document other than by their client and then only for the purposes for which it was prepared. No warranty is given for any third party data included in this document.

KEY PLAN:

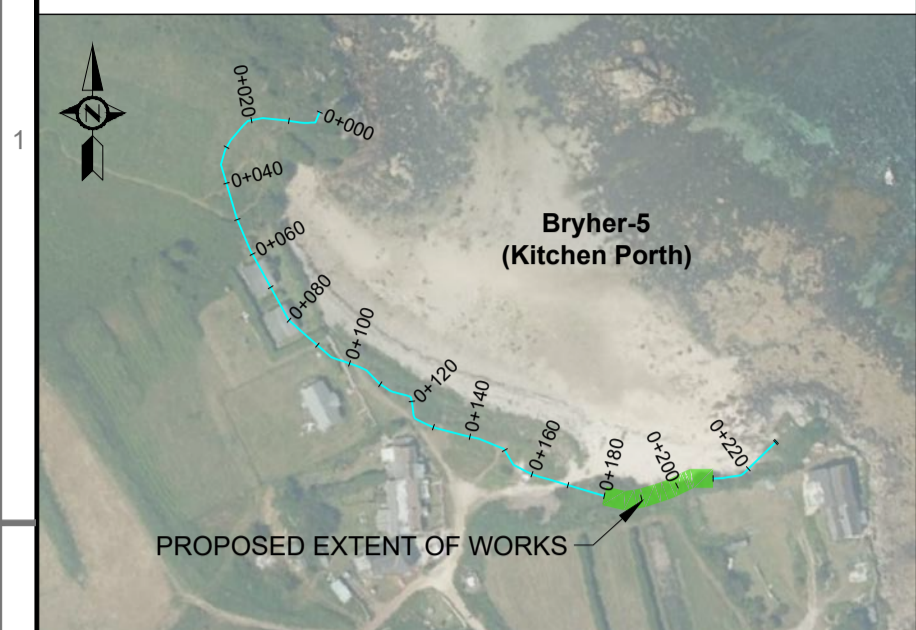

NOTES:

1. ALL DIMENSIONS ARE IN METRES UNLESS STATED OTHERWISE.
2. HORIZONTAL DATUM IS REFERENCED TO OSGB 1936 BRITISH NATIONAL GRID.
3. VERTICAL DATUM IS IN METRES, ORDNANCE DATUM.
4. SETTING OUT POINTS TO BE AGREED FOLLOWING DETAILED SURVEYS.
5. ALL LEVELS TO BE CONFIRMED FOLLOWING ON SITE SURVEY.
6. BACKGROUND IMAGE REPRODUCED FROM BING MAPS, © 2021 MICROSOFT.
7. EXISTING MASONRY WALL SECTION SHOWN IS ILLUSTRATIVE OF A FIXED STRUCTURE ONLY.
8. FOR GENERAL NOTES REFER TO DRAWING No. DKR6499-000-D102.
9. FOR GENERAL ARRANGEMENT LAYOUT REFER TO DRAWING No. DKR6499-210-D114.
10. TYPICAL EXISTING BEACH PROFILE SHOWN IS AT CHAINAGE 180.

HAZARDS WARNING

1! PUBLIC ACCESS TO BEACHES
 2! WORKING NEAR WATER IN TIDAL ENVIRONMENT
 4! LARGE ROCKS & VOIDS

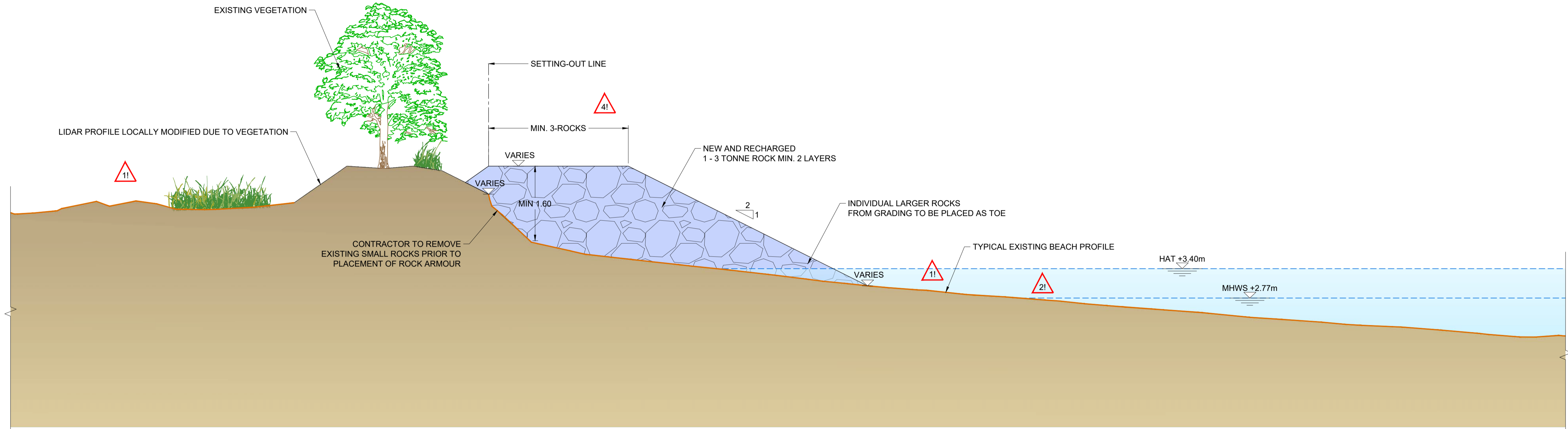

TIDE LEVELS	
mOD	
HAT	+3.40m
MHWS	+2.77m
MHWN	+1.44m
MLWN	-0.87m
MLWS	-2.18m
LAT	-2.82m

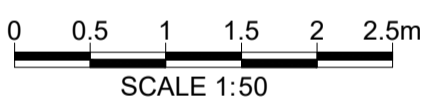

SECTION A-A
Ch.0+200

01	ISSUED FOR APPROVAL	WST	AGC	AJO	27 JUN 22
REV	DRAWING STATUS	DRN.	APPR	AUTH.	DATE

CLIENT:
THE COUNCIL OF THE ISLES OF SCILLY

MARINE CONSULTANT:

HR Wallingford
 Howbery Park, Wallingford
 Oxfordshire OX10 8BA
 United Kingdom
 Tel: +44(0)1491 835381
 Fax: +44(0)1491 832233
www.hrwallingford.com

PROJECT:
**ISLES OF SCILLY
 DESIGN SERVICES FOR OFF ISLANDS
 COASTAL EROSION DEFENCE AND
 DUNE MANAGEMENT**

DRAWING TITLE:
**BRYHER 5 - KITCHEN PORTH
 TYPICAL SECTION**

SCALE:
1:50

SHEET SIZE:
A1

DRAWING No:
DKR6499-210-D350

REV:
01

I:\work\local\projects\live\dkr6499-210-D350\01_Bryher 5-Kitchen Porth-Typical Section.dwg
 WST
 27/06/22

HR Wallingford has prepared this document under the terms of the contract between them and their client, for the exclusive use of that client. HR Wallingford accepts no liability for any use of this document other than by their client and then only for the purposes for which it was prepared. No warranty is given for any third party data included in this document.

KEY PLAN:



NOTES:

1. ALL DIMENSIONS ARE IN METRES UNLESS STATED OTHERWISE.
2. HORIZONTAL DATUM IS REFERENCED TO OSGB 1936 BRITISH NATIONAL GRID.
3. VERTICAL DATUM IS IN METRES, ORDNANCE DATUM.
4. SETTING OUT POINTS TO BE AGREED FOLLOWING DETAILED SURVEYS.
5. ALL LEVELS TO BE CONFIRMED FOLLOWING ON SITE SURVEY.
6. BACKGROUND IMAGE REPRODUCED FROM BING MAPS, © 2021 MICROSOFT.
7. EXISTING QUAY EXTENTS SHOWN IS ILLUSTRATIVE OF A FIXED STRUCTURE ONLY.
8. ALL LEVELS AND GROUYNE EXTENTS TO BE CONFIRMED FOLLOWING DETAILED SURVEY
9. FOR GENERAL NOTES REFER TO DRAWING No. DKR6499-000-D102.
10. FOR GENERAL ARRANGEMENT LAYOUT REFER TO DRAWING No. DKR6499-210-D115.

TIDE LEVELS	
mOD	
HAT	+3.40m
MHWS	+2.77m
MHWN	+1.44m
MLWN	-0.87m
MLWS	-2.18m
LAT	-2.82m

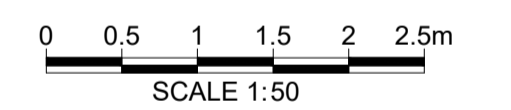

01	ISSUED FOR APPROVAL	WST	AGC	AUO	27 JUN 22
REV	DRAWING STATUS	DRN	APPR	AUTH.	DATE

CLIENT:

THE COUNCIL OF THE ISLES OF SCILLY

MARINE CONSULTANT:



HR Wallingford
Howbery Park, Wallingford
Oxfordshire OX10 8BA
United Kingdom
Tel: +44(0)1491 835381
Fax: +44(0)1491 832233

PROJECT:

**ISLES OF SCILLY
DESIGN SERVICES FOR OFF ISLANDS
COASTAL EROSION DEFENCE AND
DUNE MANAGEMENT**

DRAWING TITLE:

**BRYHER 8B - QUAY
TYPICAL SECTIONS**

SCALE:
1:50

SHEET SIZE:
A1

DRAWING No:
DKR6499-210-D360

REV:
01

HAZARDS WARNING

- 1) PUBLIC ACCESS TO BEACHES
- 2) WORKING NEAR WATER IN TIDAL ENVIRONMENT
- 3) UNKNOWN DETAIL OF EXISTING WALL
- 4) LARGE ROCKS & VOIDS

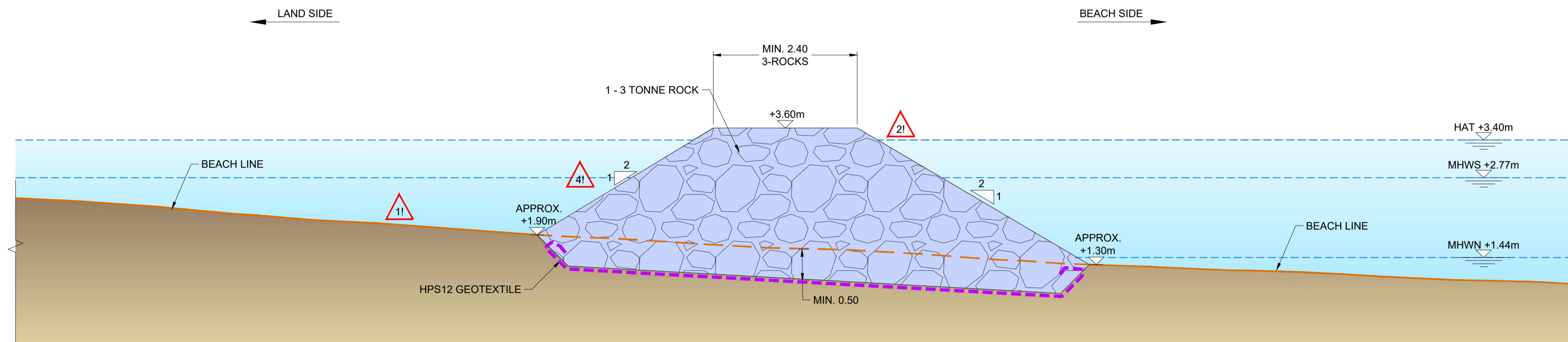

SECTION A-A
GROUYNE CROSS SECTION

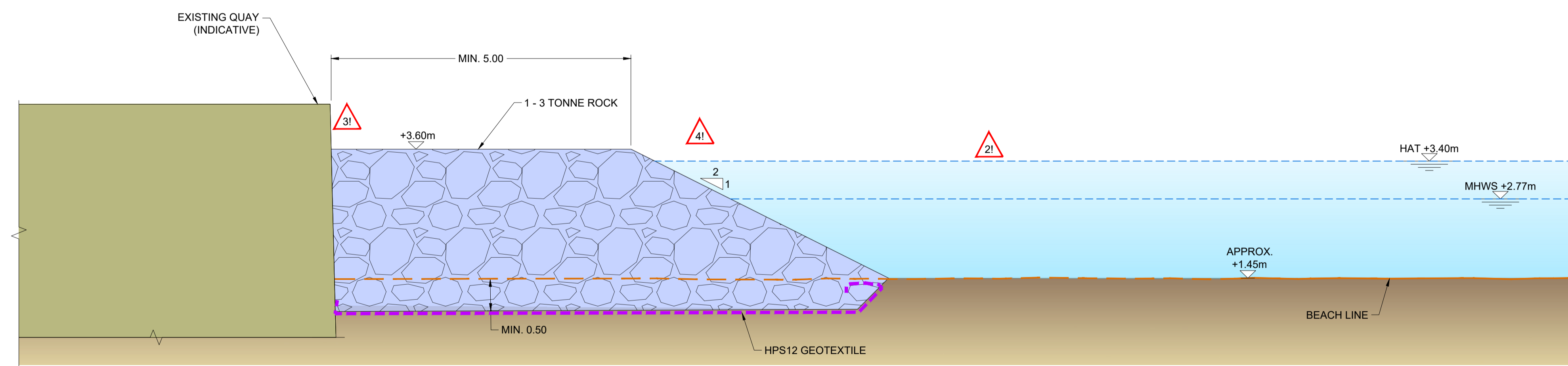

SECTION B-B
GROUYNE LONGITUDINAL SECTION

I:\work\local\projects\live\dkr6499-210-D360\01_Bryher 8B-Quay-Typical Section.dwg
 WST
 27/06/22

HR Wallingford has prepared this document under the terms of the contract between them and their client, for the exclusive use of that client. HR Wallingford accepts no liability for any use of this document other than by their client and then only for the purposes for which it was prepared. No warranty is given for any third party data included in this document.

HAZARDS WARNING

1! PUBLIC ACCESS TO BEACHES
 2! WORKING NEAR WATER IN TIDAL ENVIRONMENT
 3! SOFT AND UNSTABLE MATERIALS

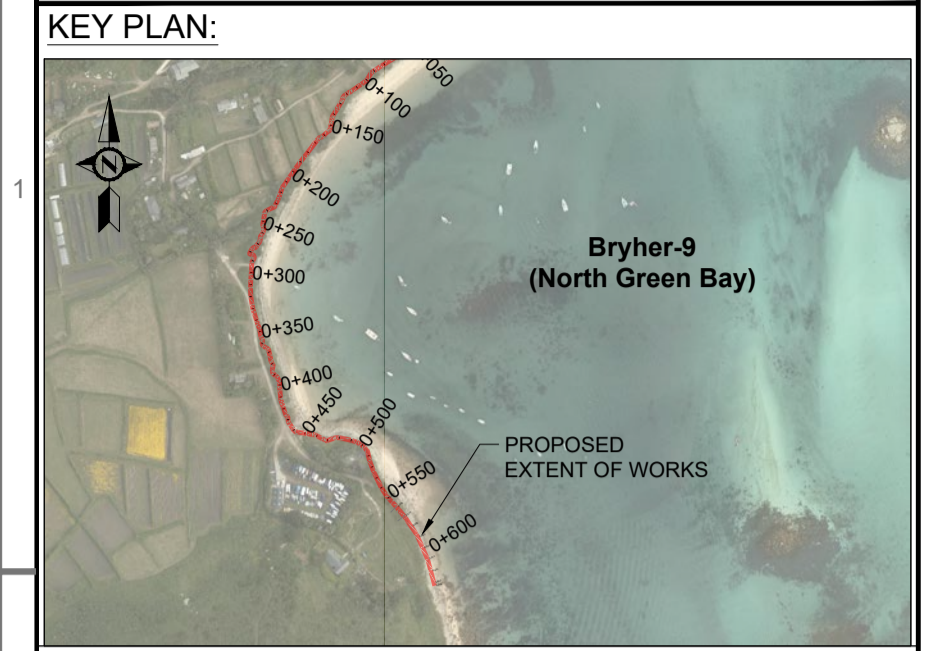

- NOTES:**
- ALL DIMENSIONS ARE IN METRES UNLESS STATED OTHERWISE.
 - HORIZONTAL DATUM IS REFERENCED TO OSGB 1936 BRITISH NATIONAL GRID.
 - VERTICAL DATUM IS IN METRES, ORDNANCE DATUM.
 - SETTING OUT POINTS TO BE AGREED FOLLOWING DETAILED TOPOGRAPHIC SURVEYS SURVEYS.
 - ALL LEVELS TO BE CONFIRMED FOLLOWING ON SITE SURVEY.
 - CONTRACTOR TO CONFIRM DETAILS OF TIE INS TO EXISTING GROUND.
 - BACKGROUND IMAGE REPRODUCED FROM BING MAPS, © 2021 MICROSOFT.
 - FOR GENERAL NOTES REFER TO DRAWING No. DKR6499-000-D102.
 - FOR GENERAL ARRANGEMENT LAYOUT REFER TO DRAWING No. DKR6499-210-D116.
 - SIGNAGE WARNING OF DANGER ON CLIMBING ON ROCK TO BE PROVIDED AS PER EMPLOYERS REQUIREMENTS.
 - TYPICAL EXISTING PROFILES SHOWN IN SECTION A-A IS AT CHAINAGE 560 AND SECTION B-B IS AT CHAINAGE 600.
 - STATED GEOBAG DIMENSIONS ARE MINIMUM DIMENSIONS.

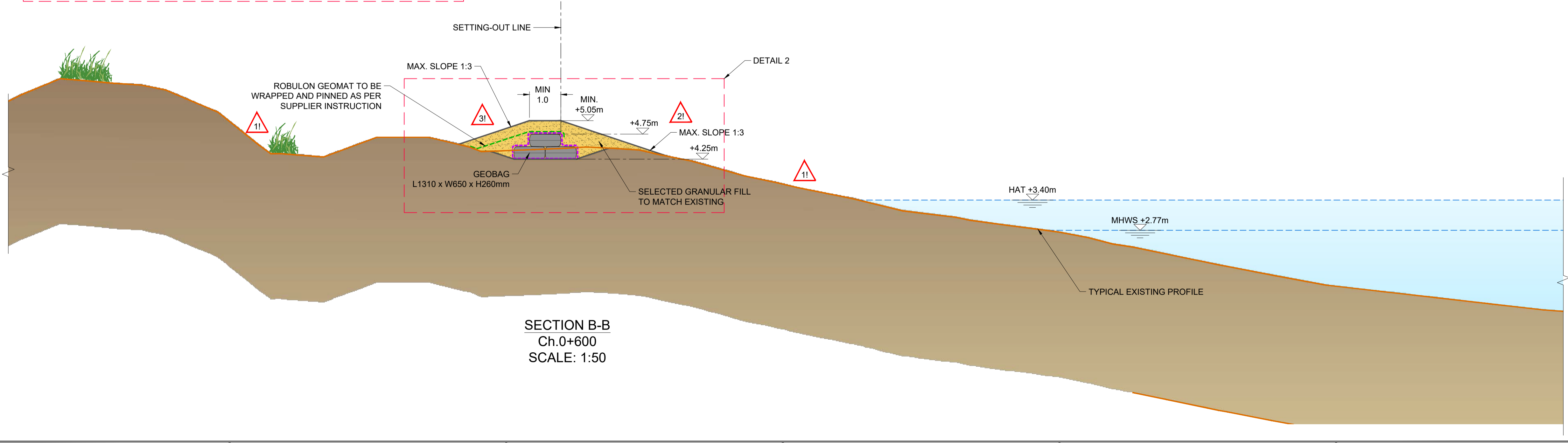
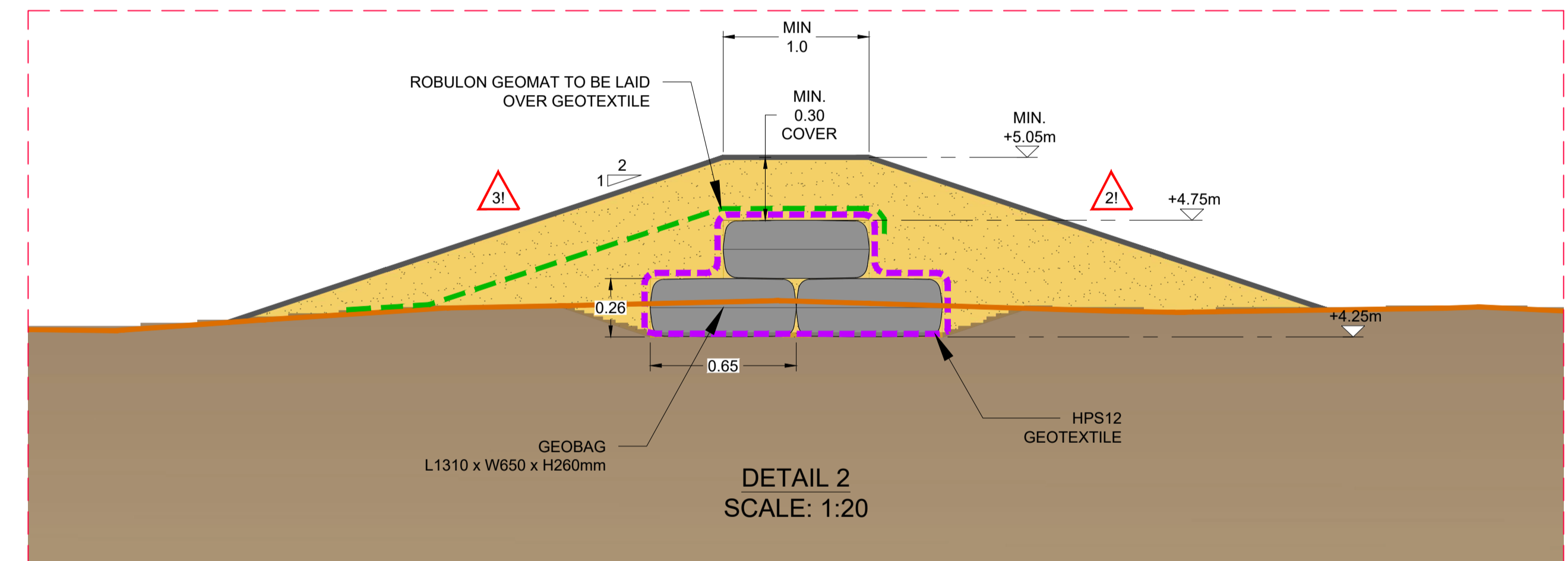
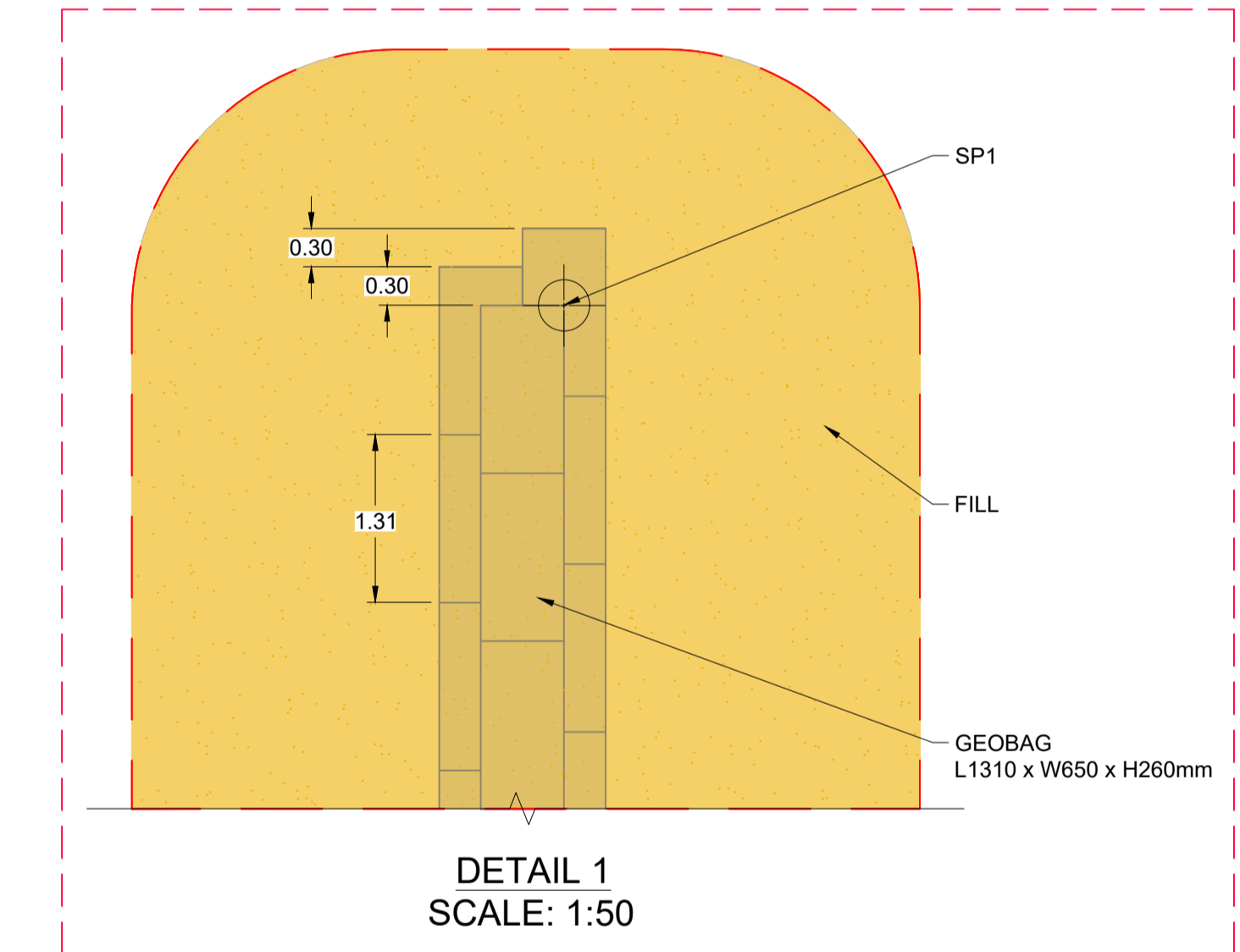
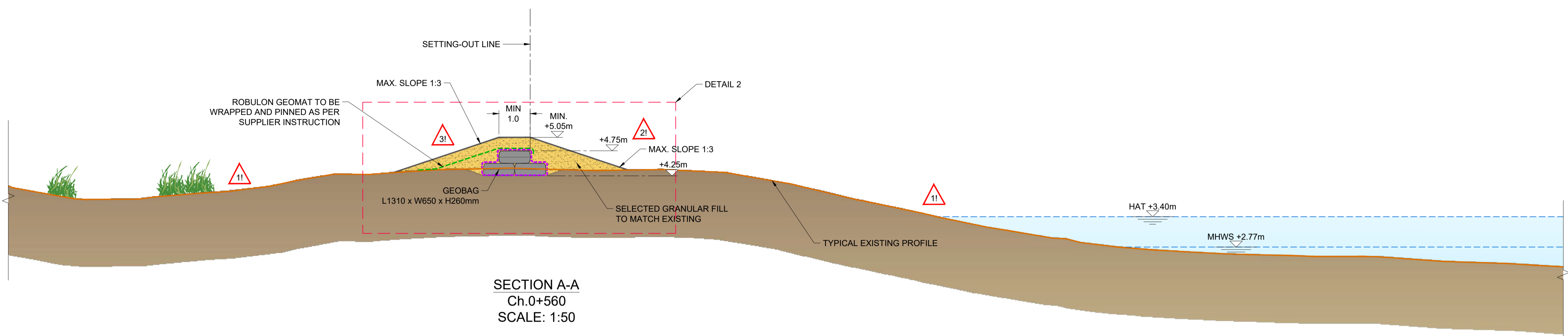

TIDE LEVELS

mOD	
HAT	+3.40m
MHWS	+2.77m
MHWN	+1.44m
MLWN	-0.87m
MLWS	-2.18m
LAT	-2.82m

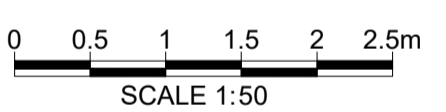

01	ISSUED FOR REVIEW	PGU	AGC	AUO	11 JUL 22
REV	DRAWING STATUS	DRN	APPR	AUTH.	DATE

CLIENT:

THE COUNCIL OF THE ISLES OF SCILLY

MARINE CONSULTANT:

HR Wallingford
 Howbery Park, Wallingford
 Oxfordshire OX10 8BA
 United Kingdom
 Tel: +44(0)1491 835381
 Fax: +44(0)1491 832233
www.hrwallingford.com

PROJECT:

**ISLES OF SCILLY
 DESIGN SERVICES FOR OFF ISLANDS
 COASTAL EROSION DEFENCE AND
 DUNE MANAGEMENT**

DRAWING TITLE:

**BRYHER 9 - NORTH GREEN BAY
 DETAILS AND TYPICAL SECTIONS**

SCALE: JUST AS SHOWN SHEET SIZE: A1

DRAWING No: DKR6499-210-D370 REV: 01

I:\mva\local\projects\wdr\dkr6499-210-D370 [02.2]_Bryher 9-North Green Bay-Typical Section_01.dwg
 PGU
 12/07/22

D CDM (2015)

Isles of Scilly Climate Resilience		Design Risk Register				Receptor	RISK LEVEL BEFORE MITIGATION			Mitigation Measure	RISK LEVEL AFTER MITIGATION			Construction, maintenance and demolition control	Proj Ref:
No.	Works/Condition	HAZARD and CONSEQUENCE (RISK) IDENTIFIED	Site staff, Public	L	C	L*C	INTENDED ACTION OR MITIGATION - DESIGN STAGE			L	C	L*C	ANTICIPATED MEASURE THAT COULD BE APPLIED BY CONTRACTOR (OR OTHERS)	Action By	
1 General															
1.1	Availability of Surveys	Availability of Surveys, Topographic, Geotechnical and Environmental Surveys, resulting in delay, costs and potential alteration to methods of delivery and construction	Site personnel and project schedule	2	4	8	Identify surveys required prior to start of Construction			2	4	8	Undertake Surveys to inform Risk	Contractor & Owner	
1.2	Work Near Water	Risk to equipment and personnel. Risk of hypothermia or drowning	Site personnel and equipment	3	5	15	Raise awareness of risk in Engineering Report; include information on waves and tidal levels in Engineering Report and tidal levels in drawings. Reduce need for excavation in the intertidal area in the design.			1	5	5	Contractor to have competent experience of working in tidal environment. Contractor to develop safe systems of work in intertidal areas including the provision of appropriate PPE. Obtain frequent weather reports to predict tidal conditions. Contractor to ensure all plant is adequately serviced and maintained. Monitoring and Early planning of construction schedule. Store Equipment safe away from intertidal area	Contractor	
1.3	Extreme high tides and storm events -	Adverse weather conditions resulting in plant being unable to track along foreshore. Weather (wind, waves, inundation of working areas). Leading to personnel and plant trapped by tidal conditions. Risk of drowning or hypothermia to site personnel.	Site personnel and equipment	2	5	10	Expected tidal ranges to be put on drawings. Controls to be investigated for weather forecast/warnings. Limit need to work near water.			1	5	5	Obtain weather forecast information on a daily basis, prepare emergency escape plan. Supervisor monitors weather forecasts and amends work accordingly. Teams to be issued with foul weather clothing. Provide plant bays and ensure adequate access. Provide appropriate PPE and link up to weather predictions for severe weather warnings.	Contractor	
1.4	Unexploded Ordnance (UXO) - Possible presence on site of unexploded ordnance.	Loss of life, injury (including hearing damage) due to explosion	Site Personnel and equipment	2	5	10	Preliminary desk based assessment indicates LOW/MEDIUM risk.			1	5	5	Detailed assessment to be obtained by Contractor. Contractor to set out mitigative measures for excavations in method statement. Detailed design review to limit excavation if possible. Contractor to prepare Appropriate Site Management documentation should be held on-site to guide and plan for the actions which should be undertaken in the event of a suspected or confirmed UXO discovery. UXO Safety and Awareness briefing for all site personnel. Ordnance team to be included on emergency contact list.	Contractor	
2 Construction Phase															
2.1 Site conditions															
2.1.1	Public access to the site	Potential for incidents with plant (beach users)	Site personnel and public	2	4	8	None applicable			2	4	8	Signage and fencing to isolate work areas where possible, whilst minimising impact to public access to the beach. Control access into area and restrict to work crews and authorised personnel only. Close access gates when area is unmanned	Contractor	
2.1.2	Soft ground	Potential for plant or personnel to become stuck in pockets of soft ground the positions of which may vary. Damage to plant and injury to personnel.	Site personnel	2	4	8	Trial pits to be located in areas of possible concern			2	4	8	Walkover survey in advance of bringing plant to beach areas. Ensure appropriate plant is used	Contractor	
2.1.3	Availability of services	Capacity of existing networks unlikely to be able to accommodate power and water demands from site. Availability of water and toilet facilities	Site personnel	3	3	9	None applicable			1	3	3	Owner to assist contractor in plans for site water and toilet facilities.	Contractor & owner	
2.1.4	Increased flood risk during works	Flood risk due to temporary lowering of defence crest levels	Site personnel and public	2	3	6	None applicable			2	3	6	Maintain a storm and extreme water level warning system and Contractor to plan for works when risk of storms is lower	Contractor & Owner	
2.2 Access															
2.2.1	Site access/delivery	Access to islands in small craft/barges through challenging seas. Risk to crew, equipment and public	Logistics personnel, public	3	5	15	Minimise hard engineering works to minimise required import of materials to the different sites and consideration of likely plant in the scale of the works			2	4	8	Limit site delivery numbers, and use of appropriate barges and ships for the selected delivery sites. Maintain a storm and extreme water level warning system and Contractor to plan for deliveries when risk of storms is lower	Contractor	
2.2.2	Marine access - General	There is challenging marine access to the Isles of Scilly due to weather and tidal restrictions. This will pose challenges for marine deliveries. There will be limiting bathymetry, hazards or rocky foreshores that is not appropriate to beach barges	Site and logistics personnel	3	4	12	High level review of each site to identify challenges to marine access and identify alternative delivery sites. Use www.navionics.com charts or similar for preliminary assessment Client has undertaken assessment of site access to identify appropriate delivery locations			2	4	8	Fuller assessment to be done to consider tide and seasonal and annual climate in addition to extremes. Bathymetry survey to be carried out and contractor to produce logistics plan for each island and identify delivery plan	Contractor & Owner	
2.2.3	Marine Access - St Agnes	Porth Killier is likely to be unsuitable for marine access as has a narrow entrance to the bay and rocky foreshore. Porth Coose is difficult for marine access, with narrow entry to the beach. Narrow tidal windows for access and risk of grounding	Site and logistics personnel	3	3	9	As above			1	3	3	Assessment of suitability of deliveries via the Ferry Quay or alternatively Periglis Beach	Contractor & Owner	
2.2.4	Marine Access - Bryher	Bryer is the most exposed of the project islands, western sites are likely to be unsuitable for marine access into the bays and eastern access will be tidally restricted	Site and logistics personnel	3	3	9	See 2.2.2			1	3	3	Assessment of suitability of Client identified delivery sites on the east of the island and plan timing of vessel access in advance for tidal access	Contractor & Owner	
2.2.5	Island infrastructure	Existing quays condition and capacities are unknown. May not be safe to bring materials and equipment through these quays and via the island roads	Site personnel, public	3	3	9	Client has undertaken assessment for options for deliveries to identify favoured landing sites and access routes on the islands			1	3	3	Owner to assist Contractor in assessing capabilities of existing island infrastructure	Contractor & Owner	
2.3 Earthworks															
2.3.1	Stockpiling of existing rocks	Individual rocks may be supporting other large rocks that could be destabilised	Site personnel	2	3	6	Include requirements for stockpile in specifications			1	3	3	Contractor to conduct walk over survey to agree which rocks to be moved and where to stockpile.	Contractor	
2.3.2	Unstable excavation	Slope instability during excavation works	Site personnel	2	4	8	Shallow excavations where possible and max. excavated profile of 1 in 1 selected			1	4	4	Contractor to make site operatives aware of dangers prior to working on new profiles/slopes, via tool box talks and daily briefings. Contractor to undertake visual assessment of new slopes to check for signs of deterioration, particularly after storms or periods of high rainfall.	Contractor	
2.3.3	Utilities	Uncovering electrical and telephone cabling at St Martin's with potential risk to power supply and possible electrocution Unknown and unmarked services may be uncovered during excavations	Site personnel and public	1	5	5	Searches have been undertaken to identify pipes and cabling and approximate routing. Where known, approximate locations have been marked on drawings			1	5	5	Contractor to carry out CAT scans and excavate by hand in areas of possible pipes and cabling	Contractor	

Isles of Scilly Climate Resilience		Design Risk Register				Receptor			RISK LEVEL BEFORE MITIGATION			Mitigation Measure			RISK LEVEL AFTER MITIGATION			Construction, maintenance and demolition control		Proj Ref:	
No.	Works/Condition	HAZARD and CONSEQUENCE (RISK) IDENTIFIED				Site staff, Public			INTENDED ACTION OR MITIGATION - DESIGN STAGE			ANTICIPATED MEASURE THAT COULD BE APPLIED BY CONTRACTOR (OR OTHERS)			Action By						
L	C	L	C	L	C	L	C	L	C	L	C	L	C	L	C	L	C	L	C		
2.3.4	Plant movements	Movement and operation of construction vehicles risk to site personnel and public				Site personnel and public			2	4	8	Footprints of proposed works to be kept clear from footpaths/tracks as far as possible Client has identified access routes and compound and stockpile areas on each island			1	4	4	Full briefing to Contractor drivers, site fencing and signage and use of banksmen as appropriate. Signage and fencing to isolate work areas from public access Control access into area and restrict to work crews and authorised personnel only. Close access gates when area is unmanned			Contractor & Owner
2.4 Rockworks																					
2.4.1	Unstable rock stockpile	The rock stockpile is not a designed structure and the stability can therefore not be relied upon. Hazard of crushing from moving rock in proximity to the stockpile				Site personnel			2	5	10	Include requirements for stockpile in specifications			2	3	6	Contractor to make site operatives aware of dangers prior to working on in proximity to rock stockpiles, via tool box talks and daily briefings. Contractor to undertake visual assessment of stockpile, particularly after rock extraction, storms or periods of high rainfall.			Contractor
2.4.2	Rock delivery	Rock delivery by barge and interaction with public and exposure to storm conditions				Public, personnel			2	4	8	Plan for re-use of existing rock where possible to minimise need to import			1	4	4	Contractor to cordon off areas during these operations. Contractor to make site operatives aware of dangers of rock transportation, via tool box talks and daily briefings. Contractor to maintain marshals at key access points to ensure safe transportation and interaction with public. Contractor to monitor storm conditions and avoid transportation of rock during storms.			Contractor
2.4.3	Rock placing	Rock unstable during and following placement or due to degradation of slope profiles.				Public, personnel			2	4	8	Flatten slopes and place in 2 layers to get good interlock			1	4	4	Contractor to make site operatives aware of dangers prior to working on new profiles/slopes, via tool box talks and daily briefings. Inspection by Contractor and Owner after storms to assess slopes.			Contractor
3 Operation																					
3.1	Flood risk (permanent situation)	Flood risk due to overtopping waters.				Public			2	3	6	Critical sections of beaches to have interventions to protect infrastructure behind. Some areas will still be vulnerable to flooding			2	2	4	Maintain a storm and extreme water level warning system			Owner
3.1	Operation of flood barrier	Flood barrier protects the slipway crest at Great Porth beach on Bryher, if not inserted ahead of a storm the area behind could flood				Public			2	3	6	Gates are to be light units that can be quickly installed by 1 person with appropriate training			1	3	3	Maintain a storm and extreme water level warning system and identify individuals responsible for installing the gates and provide any necessary training			Owner
3.1	Public access to beaches	The proposed works will introduce rock at previous beach access points. Risk to public from falling on and between rocks				Public			2	4	8	Highlight paths and access points to be changed Signage adjacent to rock structures warning of the hazards to be considered			1	4	4	Introduce signage and fencing to manage beach access points and access to rock revetments			Owner
4 Demolition																					
4.1	General	The hazards set out in Section 2 apply equally to the demolition.				Site personnel, public			2	3	6	As above			2	3	6	As above.			Owner
NOTES																					
The hazards and risks listed here are the key H&S risks identified for the proposed works. Generic risks such as slips, trips and falls or remote working that are relevant for any construction works are not included here but should form part of contractor's risk assessment and environmental risks need to be covered separately																					
Key:	Likelihood	1 - Unlikely to occur in relevant period. 2 - Likely to occur in relevant period. 3 - Likely to occur several times in the relevant period																			
	Consequence	5 - Death or total systems loss 4 - Major injury or illness. Major damage or environmental impact. 3 - Lost time injury or illness. Damage or environmental impact. 2 - First aid incident. Routine maintenance repair. 1 - Very minor. Little consequence.																			
	Likelihood x Consequence (See also CIRIA SP125).	10-15 Very High Risk - not acceptable. Apply mitigation. Seek approval if significant risk remains. 6-9 High Risk - Apply mitigation. Seek approval if risk cannot be reasonably and practically be reduced below "this" level. 1 - 5 Low Risk - May be accepted if all reasonably practicable control measures in place.																			
Prepared by:	AGC					Title:			Project Engineer												
Checked by:	AUO					Title:			Project Manager												
Approved by:	AUO					Title:			Project Manager												

E Utility Plans

Contact Us

Mapping Enquiries: All areas 0121 623 9780
General Enquiries: All areas 0800 096 3080

**Report damage immediately – KEEP EVERYONE AWAY FROM THE AREA
 0800 6783 105**

Date Requested: 21/07/2021
 Job Reference: 22745493
 Site Location: 88173 15262
 Requested by: Mr Andy Campbell
 Your Scheme/Reference: CAS

IMPORTANT NOTICES

- This information is given as a guide only and its accuracy cannot be guaranteed. Services or recent additions to the network may not be shown.
- Cables, overhead lines & substations owned by other electricity network owners or private companies may be present and may not be shown.
- You should always verify exact locations of cables using a cable locator and by careful use of hand tools in accordance with HSE guidance note HSG47.
- When working within 10m of any overhead electric line you should follow the requirements of HSE Guidance Note GS6.
- For further advice on working near our electricity cables or lines, call our Contact Centre on 0800 096 3080.
- Advice should be sought from the Western Power Distribution Contact Centre for any work that is to take place in proximity to 66kV or 132kV underground cables and 66kV 132kV overhead lines – 0800 096 3080

Overhead Line		Underground Cable	
	PL		
	Service		
	LV		
	HV (11kV)		
	HV (33kV)		
	HV (66kV)		
	HV (132kV)		
SURF Telecoms		Pilot Cables	
	S S		P P
Link Box			Pole Mounted Transformer
			Ground Mounted Transformer
Site Location			

Crown Copyright © All Rights Reserved. Ordnance Survey Licence numbers: 100022488, 100024877 & 100021807.
 WPD Copyright: This copy has been made by or with the authority of Western Power Distribution (WPD) pursuant to Section 47 of the Copyright Designs and Patents Act 1988 unless that Act provides a relevant exception to copyright the copy must not be copied without the prior permission of the copyright owner

Overview

Contact Us

Mapping Enquiries: All areas 0121 623 9780
General Enquiries: All areas 0800 096 3080

**Report damage immediately – KEEP EVERYONE AWAY FROM THE AREA
 0800 6783 105**

Date Requested: 21/07/2021
 Job Reference: 22745493
 Site Location: 88173 15262
 Requested by: Mr Andy Campbell
 Your Scheme/Reference: CAS
 Exact Scales:
 1:1250 Area or Circle dig site
 1:500 Line dig site

IMPORTANT NOTICES

- This information is given as a guide only and its accuracy cannot be guaranteed. Services or recent additions to the network may not be shown.
- Cables, overhead lines & substations owned by other electricity network owners or private companies may be present and may not be shown.
- You should always verify exact locations of cables using a cable locator and by careful use of hand tools in accordance with HSE guidance note HSG47.
- When working within 10m of any overhead electric line you should follow the requirements of HSE Guidance Note GS6.
- For further advice on working near our electricity cables or lines, call our Contact Centre on 0800 096 3080.
- Advice should be sought from the Western Power Distribution Contact Centre for any work that is to take place in proximity to 66kV or 132kV underground cables and 66kV 132kV overhead lines – 0800 096 3080

Overhead Line		Underground Cable	
	PL		
	Service		
	LV		
	HV (11kV)		
	HV (33kV)		
	HV (66kV)		
	HV (132kV)		
SURF Telecoms		Pilot Cables	
	S		P
Link Box			Pole Mounted Transformer
			Ground Mounted Transformer
Site Location			
	Line/Area		

Crown Copyright © All Rights Reserved. Ordnance Survey Licence numbers: 100022488, 100024877 & 100021807.
 WPD Copyright: This copy has been made by or with the authority of Western Power Distribution (WPD) pursuant to Section 47 of the Copyright Designs and Patents Act 1988 unless that Act provides a relevant exception to copyright the copy must not be copied without the prior permission of the copyright owner

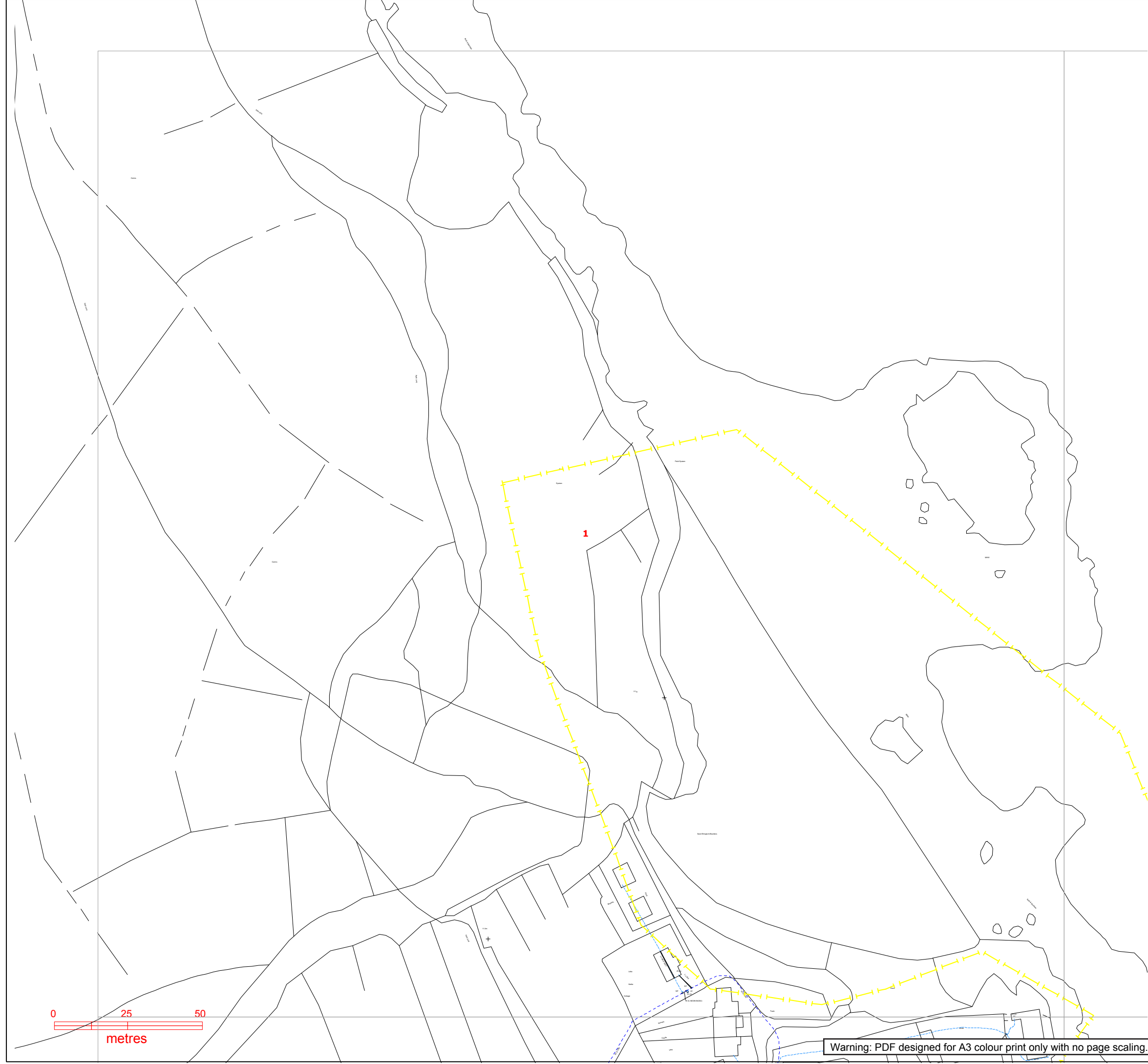

Warning: PDF designed for A3 colour print only with no page scaling.

Plans generated by DigSAFE Pro (tm) software provided by Linesearchbeforeudig

Contact Us

Mapping Enquiries: All areas 0121 623 9780
General Enquiries: All areas 0800 096 3080

**Report damage immediately – KEEP EVERYONE AWAY FROM THE AREA
 0800 6783 105**

Date Requested: 21/07/2021
 Job Reference: 22745493
 Site Location: 88173 15262
 Requested by: Mr Andy Campbell
 Your Scheme/Reference: CAS
 Exact Scales:
 1:1250 Area or Circle dig site
 1:500 Line dig site

IMPORTANT NOTICES

- This information is given as a guide only and its accuracy cannot be guaranteed. Services or recent additions to the network may not be shown.
- Cables, overhead lines & substations owned by other electricity network owners or private companies may be present and may not be shown.
- You should always verify exact locations of cables using a cable locator and by careful use of hand tools in accordance with HSE guidance note HSG47.
- When working within 10m of any overhead electric line you should follow the requirements of HSE Guidance Note GS6.
- For further advice on working near our electricity cables or lines, call our Contact Centre on 0800 096 3080.
- Advice should be sought from the Western Power Distribution Contact Centre for any work that is to take place in proximity to 66kV or 132kV underground cables and 66kV 132kV overhead lines – 0800 096 3080

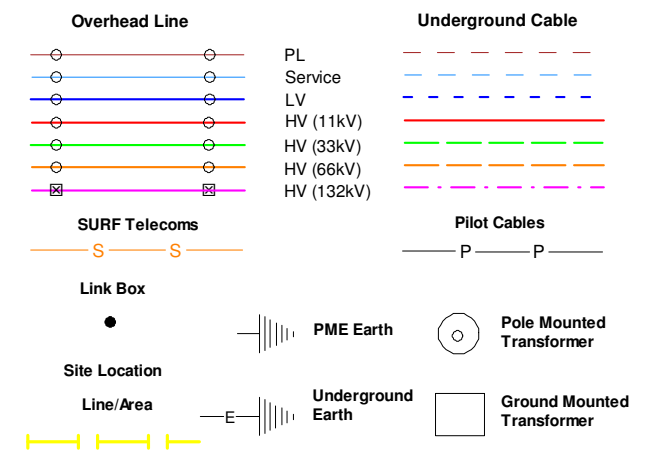

Crown Copyright © All Rights Reserved. Ordnance Survey Licence numbers: 100022488, 100024877 & 100021807.
 WPD Copyright: This copy has been made by or with the authority of Western Power Distribution (WPD) pursuant to Section 47 of the Copyright Designs and Patents Act 1988 unless that Act provides a relevant exception to copyright the copy must not be copied without the prior permission of the copyright owner

Warning: PDF designed for A3 colour print only with no page scaling.

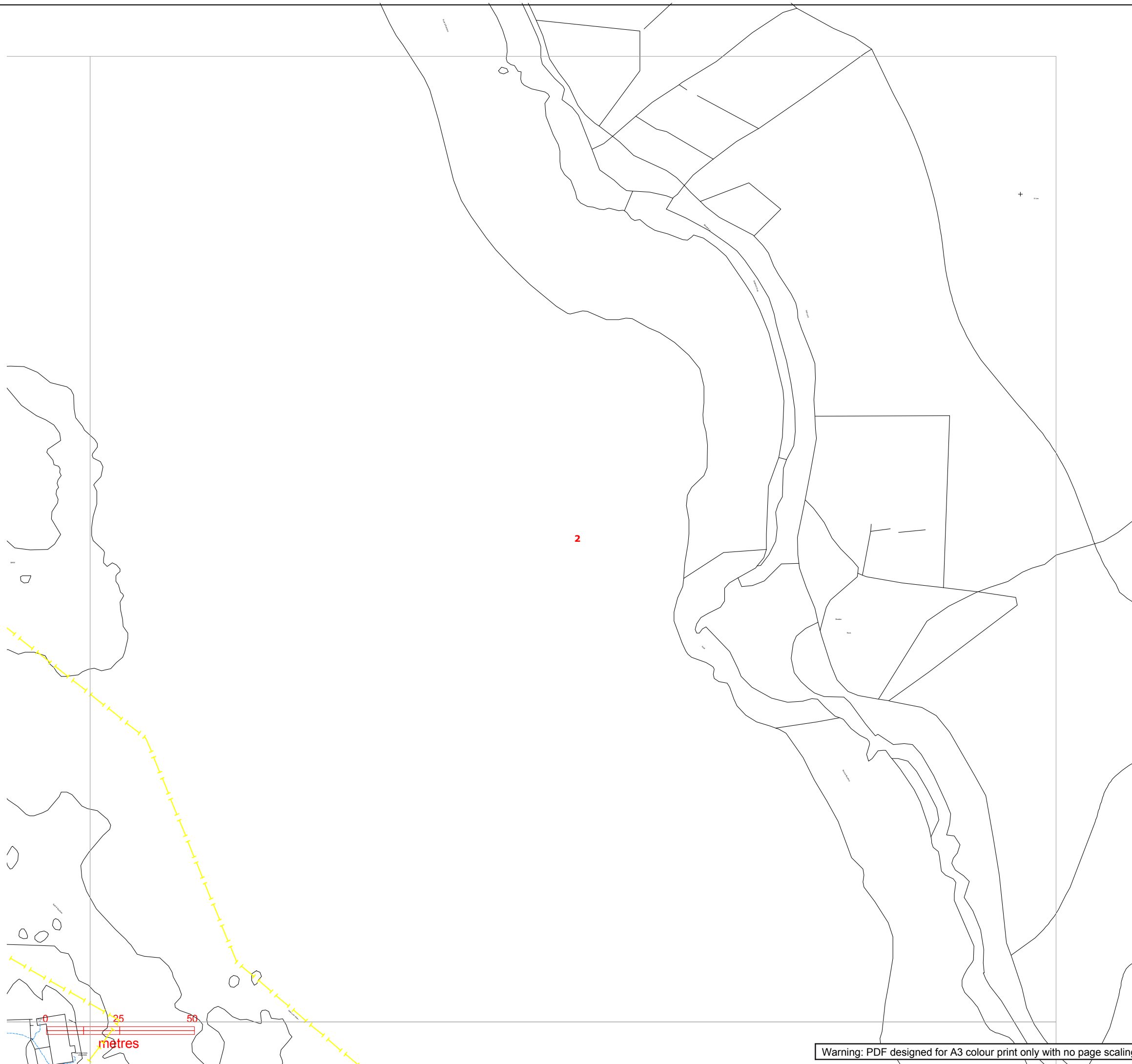

Plans generated by DigSAFE Pro (tm) software provided by LinesearchbeforeUdig



Contact Us

Mapping Enquiries: All areas 0121 623 9780
General Enquiries: All areas 0800 096 3080

**Report damage immediately – KEEP EVERYONE AWAY FROM THE AREA
 0800 6783 105**

Date Requested: 21/07/2021
 Job Reference: 22745493
 Site Location: 88173 15262
 Requested by: Mr Andy Campbell
 Your Scheme/Reference: CAS
 Exact Scales:
 1:1250 Area or Circle dig site
 1:500 Line dig site

IMPORTANT NOTICES

- This information is given as a guide only and its accuracy cannot be guaranteed. Services or recent additions to the network may not be shown.
- Cables, overhead lines & substations owned by other electricity network owners or private companies may be present and may not be shown.
- You should always verify exact locations of cables using a cable locator and by careful use of hand tools in accordance with HSE guidance note HSG47.
- When working within 10m of any overhead electric line you should follow the requirements of HSE Guidance Note GS6.
- For further advice on working near our electricity cables or lines, call our Contact Centre on 0800 096 3080.
- Advice should be sought from the Western Power Distribution Contact Centre for any work that is to take place in proximity to 66kV or 132kV underground cables and 66kV 132kV overhead lines – 0800 096 3080

Overhead Line		Underground Cable	
	PL		
	Service		
	LV		
	HV (11kV)		
	HV (33kV)		
	HV (66kV)		
	HV (132kV)		
SURF Telecoms		Pilot Cables	
	S S		P P
Link Box			PME Earth
			Pole Mounted Transformer
Site Location			Underground Earth
	Line/Area		Ground Mounted Transformer

Crown Copyright © All Rights Reserved. Ordnance Survey Licence numbers: 100022488, 100024877 & 100021807.
 WPD Copyright: This copy has been made by or with the authority of Western Power Distribution (WPD) pursuant to Section 47 of the Copyright Designs and Patents Act 1988 unless that Act provides a relevant exception to copyright the copy must not be copied without the prior permission of the copyright owner

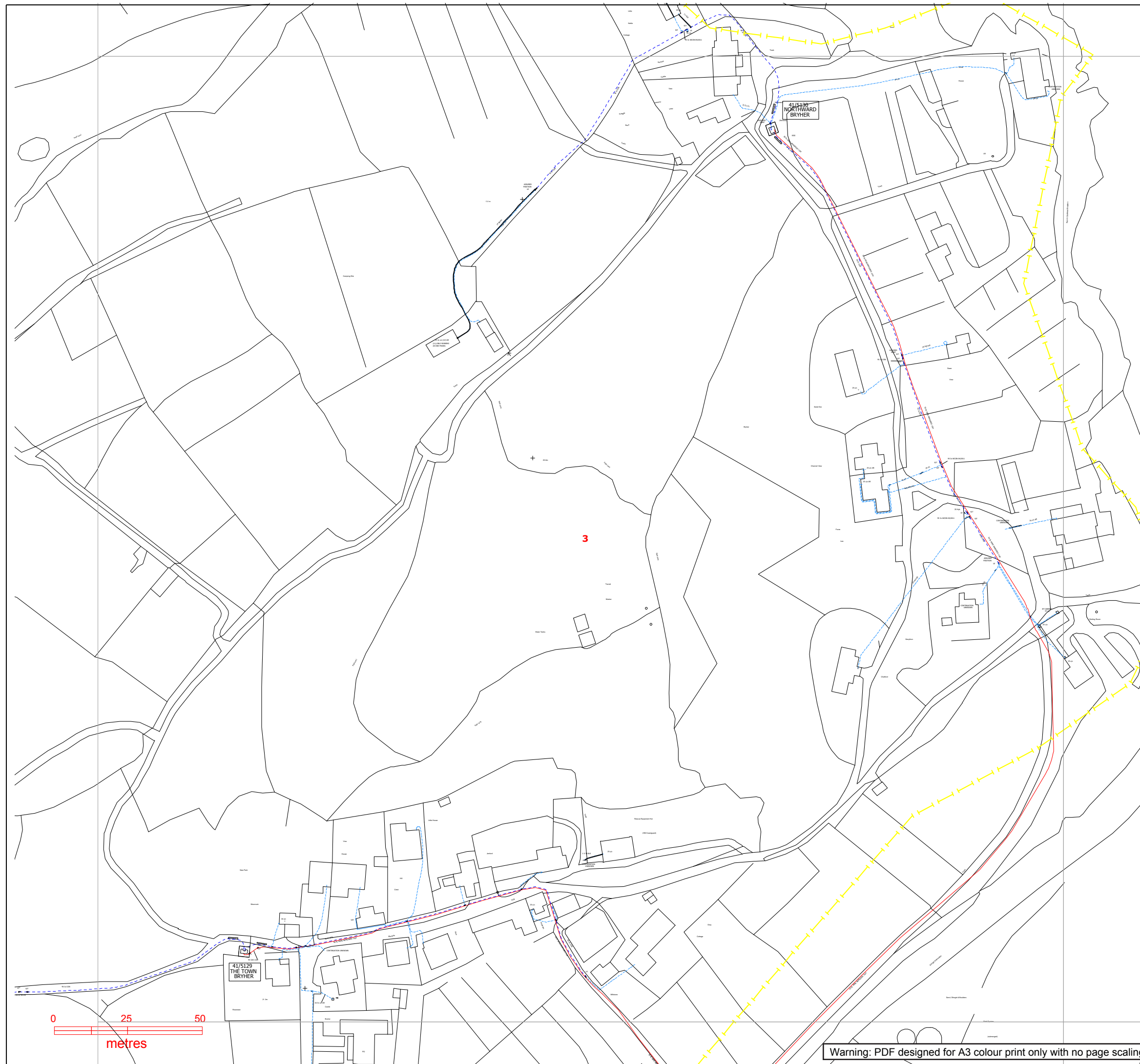

Warning: PDF designed for A3 colour print only with no page scaling.

Plans generated by DigSAFE Pro (tm) software provided by LinesearchbeforeUdig

Contact Us

Mapping Enquiries: All areas 0121 623 9780
General Enquiries: All areas 0800 096 3080

**Report damage immediately – KEEP EVERYONE AWAY FROM THE AREA
 0800 6783 105**

Date Requested: 21/07/2021
 Job Reference: 22745493
 Site Location: 88173 15262
 Requested by: Mr Andy Campbell
 Your Scheme/Reference: CAS
 Exact Scales:
 1:1250 Area or Circle dig site
 1:500 Line dig site

IMPORTANT NOTICES

- This information is given as a guide only and its accuracy cannot be guaranteed. Services or recent additions to the network may not be shown.
- Cables, overhead lines & substations owned by other electricity network owners or private companies may be present and may not be shown.
- You should always verify exact locations of cables using a cable locator and by careful use of hand tools in accordance with HSE guidance note HSG47.
- When working within 10m of any overhead electric line you should follow the requirements of HSE Guidance Note GS6.
- For further advice on working near our electricity cables or lines, call our Contact Centre on 0800 096 3080.
- Advice should be sought from the Western Power Distribution Contact Centre for any work that is to take place in proximity to 66kV or 132kV underground cables and 66kV 132kV overhead lines – 0800 096 3080

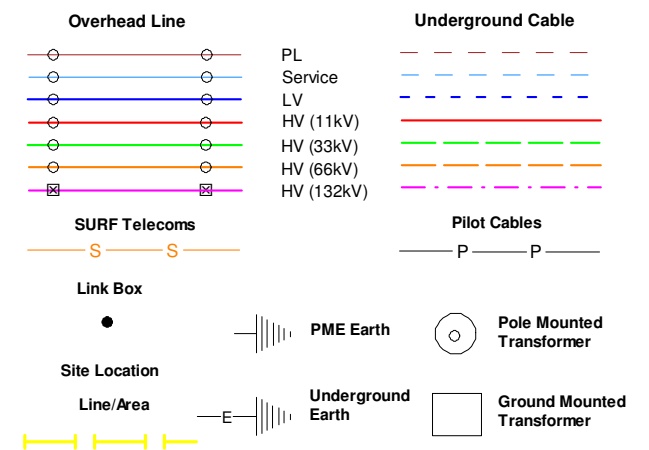

Crown Copyright © All Rights Reserved. Ordnance Survey Licence numbers: 100022488, 100024877 & 100021807.
 WPD Copyright: This copy has been made by or with the authority of Western Power Distribution (WPD) pursuant to Section 47 of the Copyright Designs and Patents Act 1988 unless that Act provides a relevant exception to copyright the copy must not be copied without the prior permission of the copyright owner

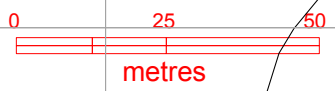
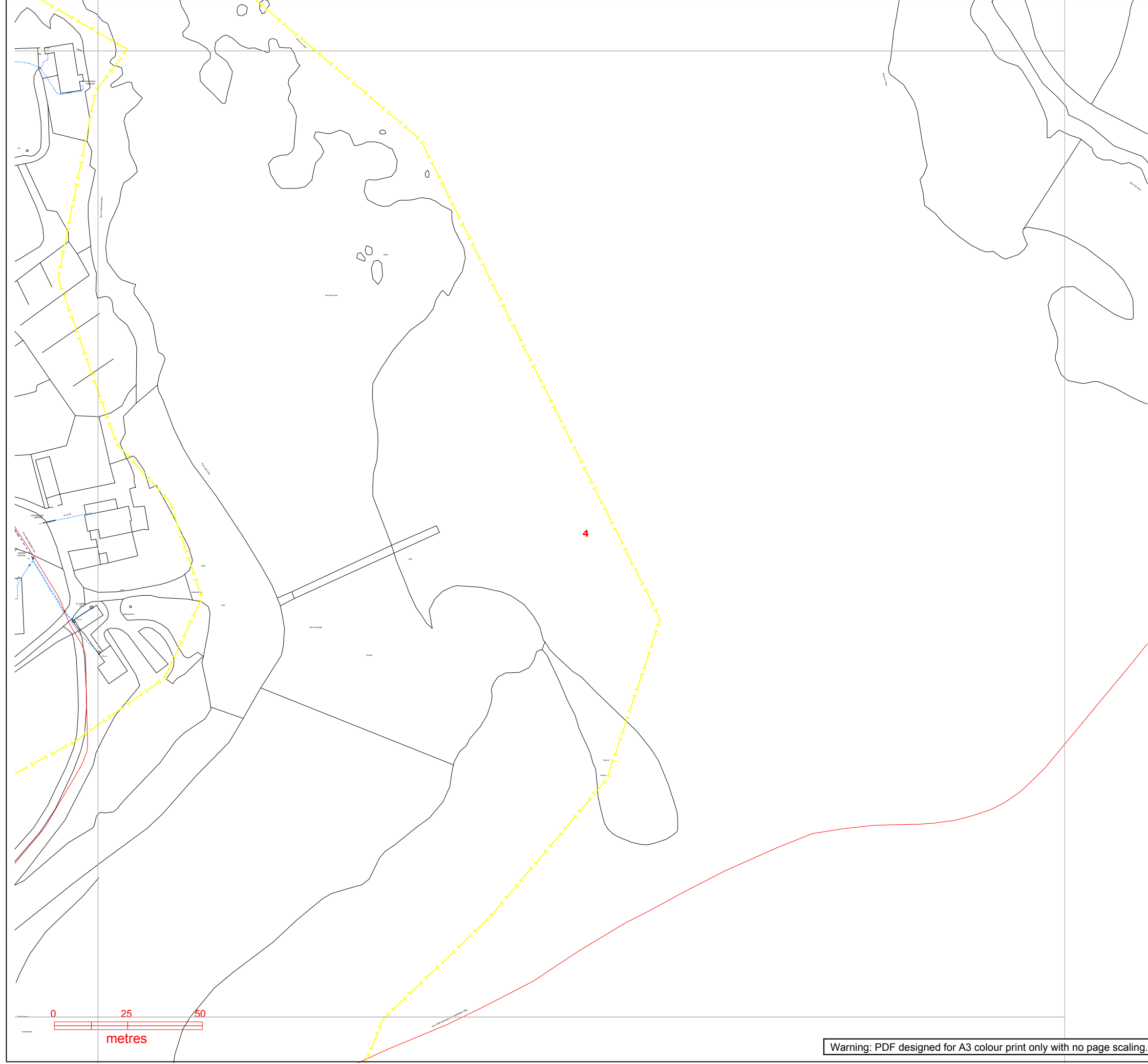

Warning: PDF designed for A3 colour print only with no page scaling.

Plans generated by DigSAFE Pro (tm) software provided by LinesearchbeforeUdig

Contact Us

Mapping Enquiries: All areas 0121 623 9780
General Enquiries: All areas 0800 096 3080

**Report damage immediately – KEEP EVERYONE AWAY FROM THE AREA
 0800 6783 105**

Date Requested: 21/07/2021
 Job Reference: 22745493
 Site Location: 88173 15262
 Requested by: Mr Andy Campbell
 Your Scheme/Reference: CAS
 Exact Scales:
 1:1250 Area or Circle dig site
 1:500 Line dig site

IMPORTANT NOTICES

- This information is given as a guide only and its accuracy cannot be guaranteed. Services or recent additions to the network may not be shown.
- Cables, overhead lines & substations owned by other electricity network owners or private companies may be present and may not be shown.
- You should always verify exact locations of cables using a cable locator and by careful use of hand tools in accordance with HSE guidance note HSG47.
- When working within 10m of any overhead electric line you should follow the requirements of HSE Guidance Note GS6.
- For further advice on working near our electricity cables or lines, call our Contact Centre on 0800 096 3080.
- Advice should be sought from the Western Power Distribution Contact Centre for any work that is to take place in proximity to 66kV or 132kV underground cables and 66kV 132kV overhead lines – 0800 096 3080

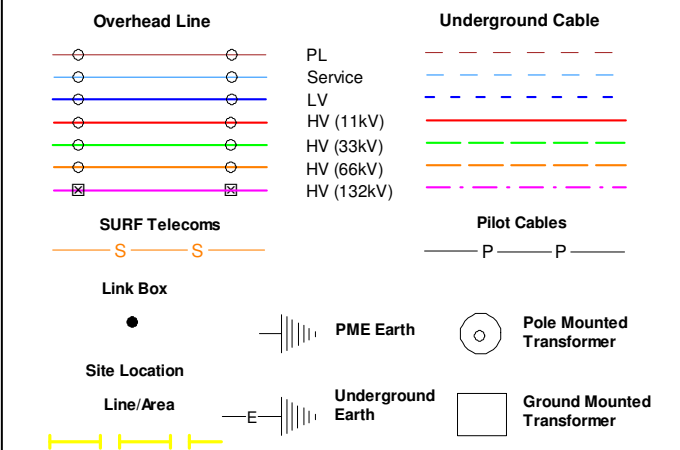

Crown Copyright © All Rights Reserved. Ordnance Survey Licence numbers: 100022488, 100024877 & 100021807.
 WPD Copyright: This copy has been made by or with the authority of Western Power Distribution (WPD) pursuant to Section 47 of the Copyright Designs and Patents Act 1988 unless that Act provides a relevant exception to copyright the copy must not be copied without the prior permission of the copyright owner

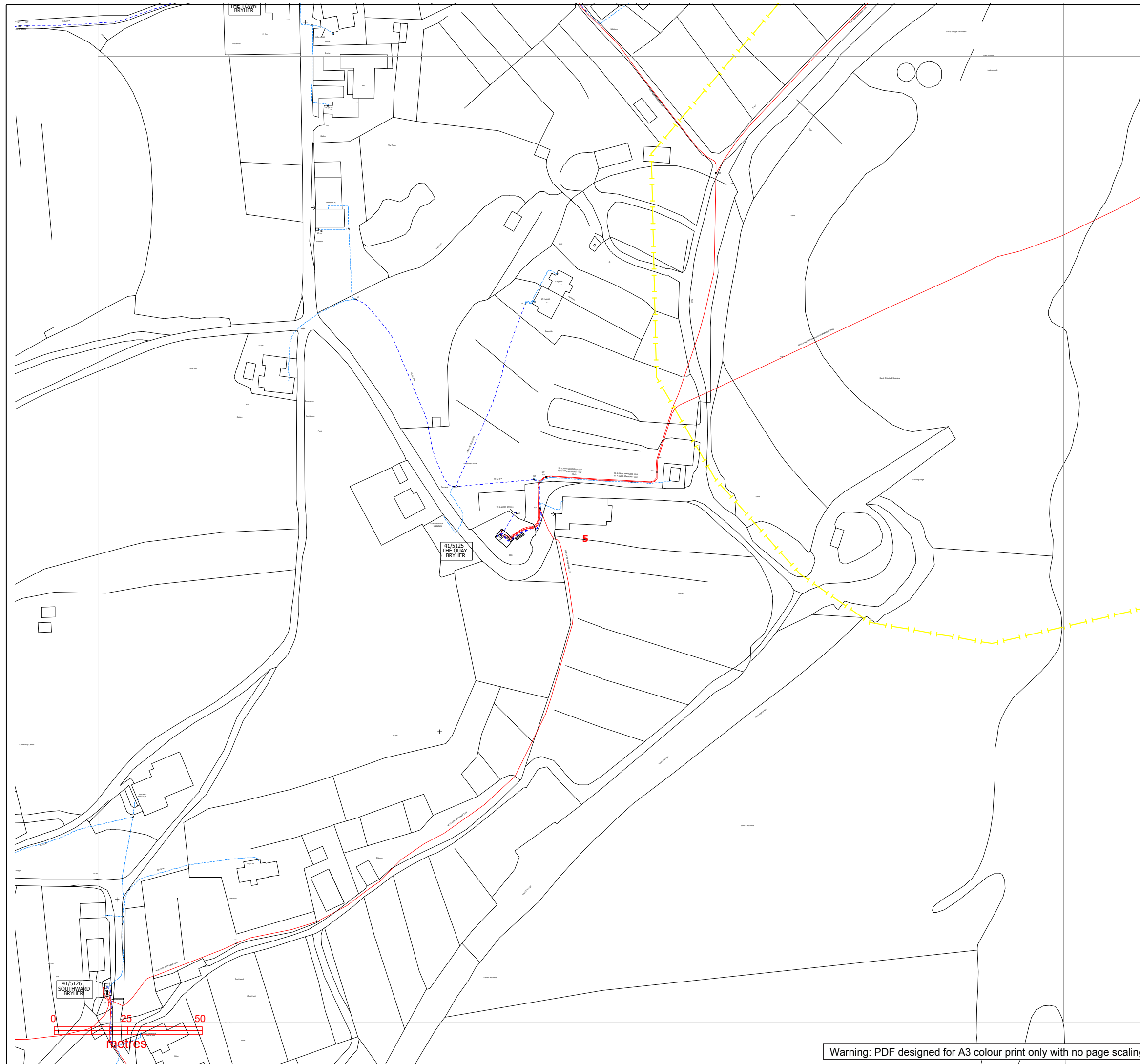

Contact Us

Mapping Enquiries: All areas 0121 623 9780
General Enquiries: All areas 0800 096 3080

**Report damage immediately – KEEP EVERYONE AWAY FROM THE AREA
 0800 6783 105**

Date Requested: 21/07/2021
 Job Reference: 22745493
 Site Location: 88173 15262
 Requested by: Mr Andy Campbell
 Your Scheme/Reference: CAS
 Exact Scales:
 1:1250 Area or Circle dig site
 1:500 Line dig site

IMPORTANT NOTICES

- This information is given as a guide only and its accuracy cannot be guaranteed. Services or recent additions to the network may not be shown.
- Cables, overhead lines & substations owned by other electricity network owners or private companies may be present and may not be shown.
- You should always verify exact locations of cables using a cable locator and by careful use of hand tools in accordance with HSE guidance note HSG47.
- When working within 10m of any overhead electric line you should follow the requirements of HSE Guidance Note GS6.
- For further advice on working near our electricity cables or lines, call our Contact Centre on 0800 096 3080.
- Advice should be sought from the Western Power Distribution Contact Centre for any work that is to take place in proximity to 66kV or 132kV underground cables and 66kV 132kV overhead lines – 0800 096 3080

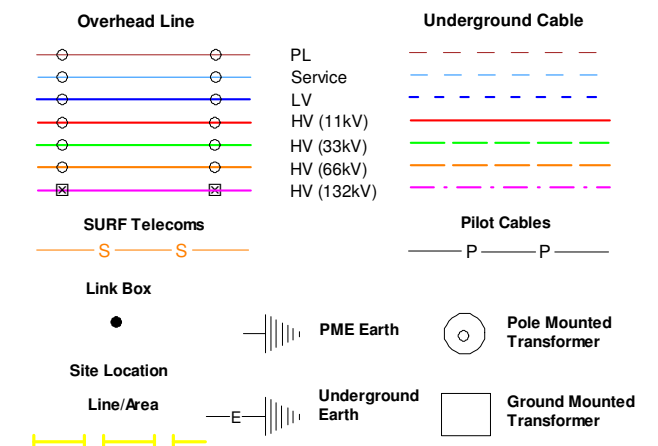

Crown Copyright © All Rights Reserved. Ordnance Survey Licence numbers: 100022488, 100024877 & 100021807.
 WPD Copyright: This copy has been made by or with the authority of Western Power Distribution (WPD) pursuant to Section 47 of the Copyright Designs and Patents Act 1988 unless that Act provides a relevant exception to copyright the copy must not be copied without the prior permission of the copyright owner

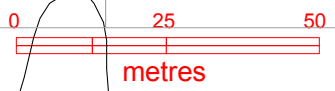
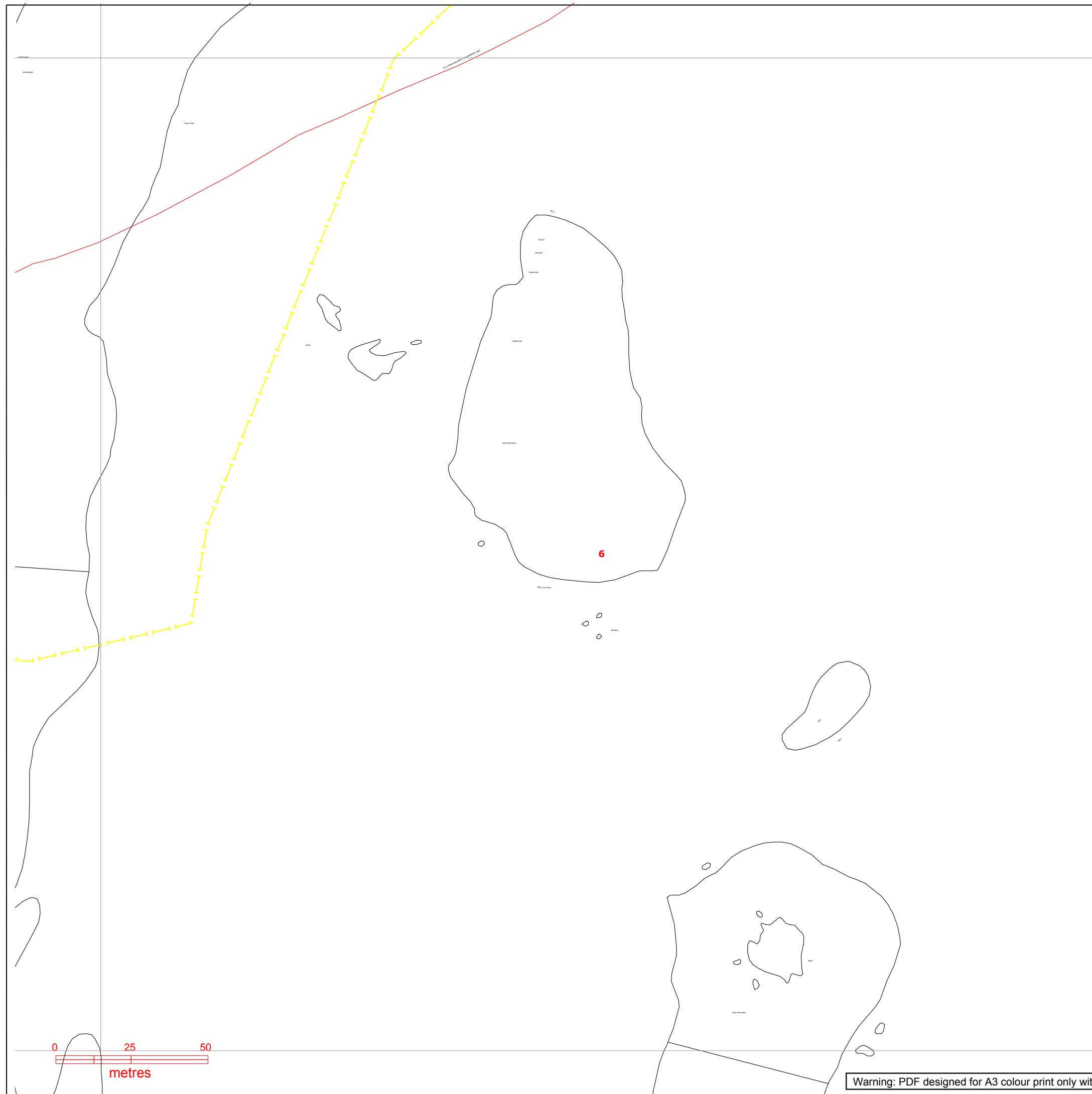

Warning: PDF designed for A3 colour print only with no page scaling.

Plans generated by DigSAFE Pro (tm) software provided by LinesearchbeforeUdig

Overview

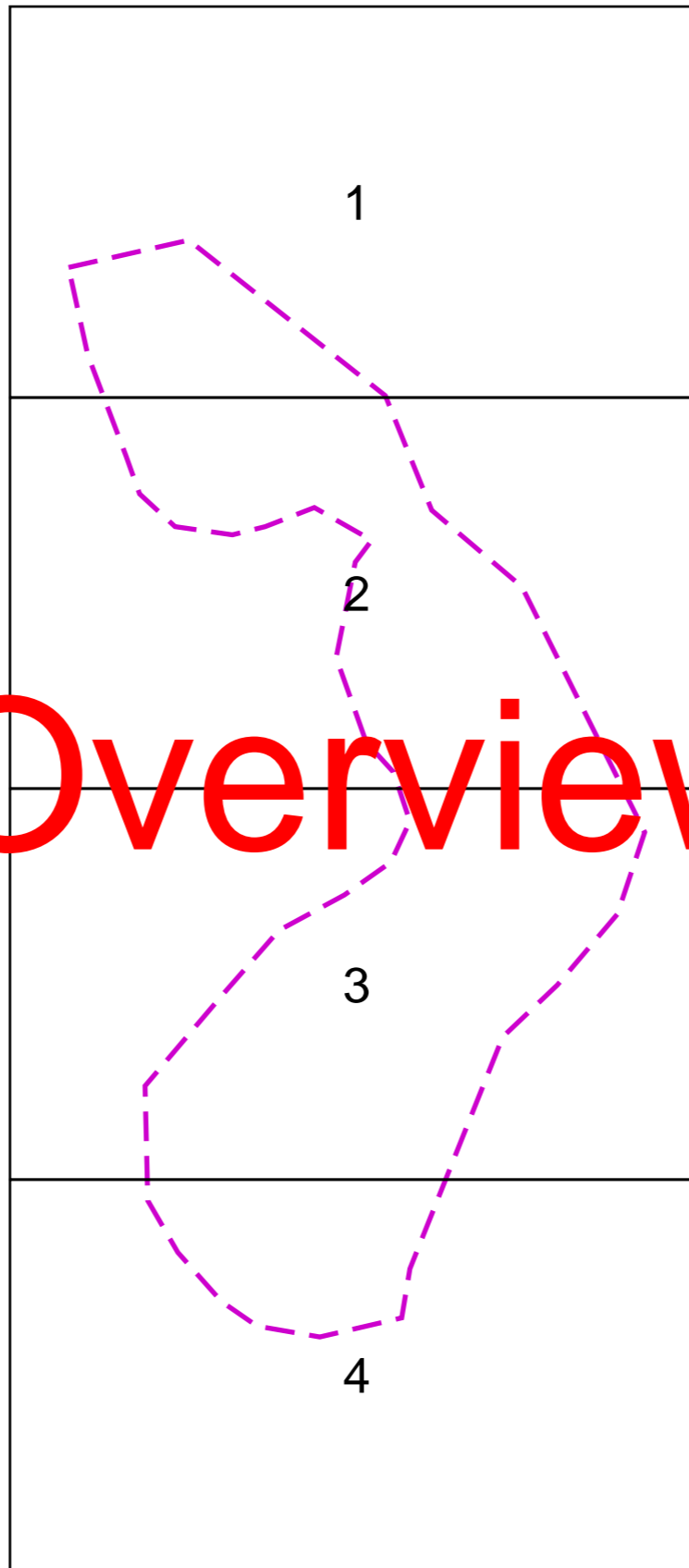

Warning: PDF designed for A3 colour print only with no page scaling

Contact Us
 Mapping Enquiries: 02920 278 912
 General Enquiries: 0800 912 2999

Date Requested: 21/07/2021
 Job Reference: 22745493
 Site Location: 88291 15253
 Requested by:
 Mr Andy Campbell
 Your Scheme/Reference: CAS

Scale: 1:5125 (When plotted at A3)

IMPORTANT NOTICES

- This information is given as a guide only and its accuracy cannot be guaranteed
- The plan only shows those pipes owned by Wales & West Utilities (WWU) as its role as a licensed Gas Transporter
- Service pipes, valves, syphons, stub connections etc. may not be shown but their presence should be anticipated
- You must use safe digging practices in accordance with HS(G)47 to establish the actual position of mains, services and other apparatus before any mechanical excavation is used
- It is your responsibility to ensure this information is provided to all persons working near our plant
- If in doubt call the WWU dig team on 02920 278912

In case of an emergency call 0800 111 999

Dig Sites

- Area: Line:
- Low Pressure (LP) 21mbar – 75mbar
- Medium Pressure (MP) 350mbar – 2bar
- Intermediate Pressure (IP) 2bar – 7bar
- High Pressure (HP) >7bar

- Line/Fire Valve
- Governor Station
- Change of Diameter
- End Cap
- Depth of cover



Smell gas?
 Call the Gas Emergency Service on 0800 111 999.

Dial before you dig
 We need 10 days' notice

Go ahead
 Done your research? Now you can dig safely.

Investigate
 Before you dig, make sure you know what's below.

Dial
 Call 029 2027 8912 before you start work.

1

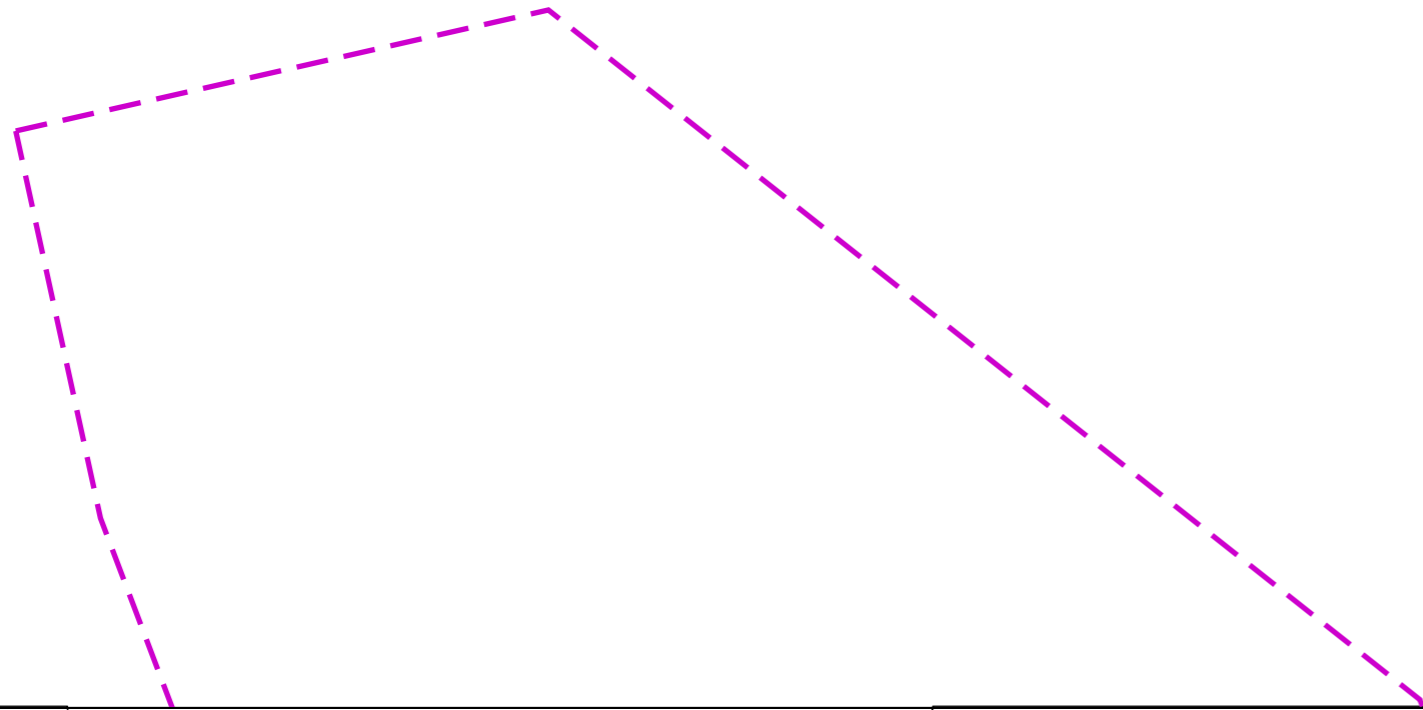

Warning: PDF designed for A3 colour print only with no page scaling

Contact Us
Mapping Enquiries: 02920 278 912
General Enquiries: 0800 912 2999

Date Requested: 21/07/2021
Job Reference: 22745493
Site Location: 88291 15253
Requested by:
Mr Andy Campbell
Your Scheme/Reference: CAS

Scale: 1:1250 (When plotted at A3)

IMPORTANT NOTICES

- This information is given as a guide only and its accuracy cannot be guaranteed
- The plan only shows those pipes owned by Wales & West Utilities (WWU) as its role as a licensed Gas Transporter
- Service pipes, valves, syphons, stub connections etc. may not be shown but their presence should be anticipated
- You must use safe digging practices in accordance with HS(G)47 to establish the actual position of mains, services and other apparatus before any mechanical excavation is used
- It is your responsibility to ensure this information is provided to all persons working near our plant
- If in doubt call the WWU dig team on 02920 278912

In case of an emergency call 0800 111 999



Dig Sites	Area:	Line:
	Low Pressure (LP) 21mbar – 75mbar	
	Medium Pressure (MP) 350mbar – 2bar	
	Intermediate Pressure (IP) 2bar – 7bar	
	High Pressure (HP) >7bar	

- Line/Fire Valve
- Governor Station
- Change of Diameter
- End Cap
- Depth of cover



Smell gas?
Call the Gas Emergency Service on
0800 111 999.

Dial before you dig

We need 10 days' notice

Dial
before you start work.
Call 029 2027 8912

Investigate
Before you dig, make sure
you know what's below.

Go ahead
Done your research?
Now you can dig safely.

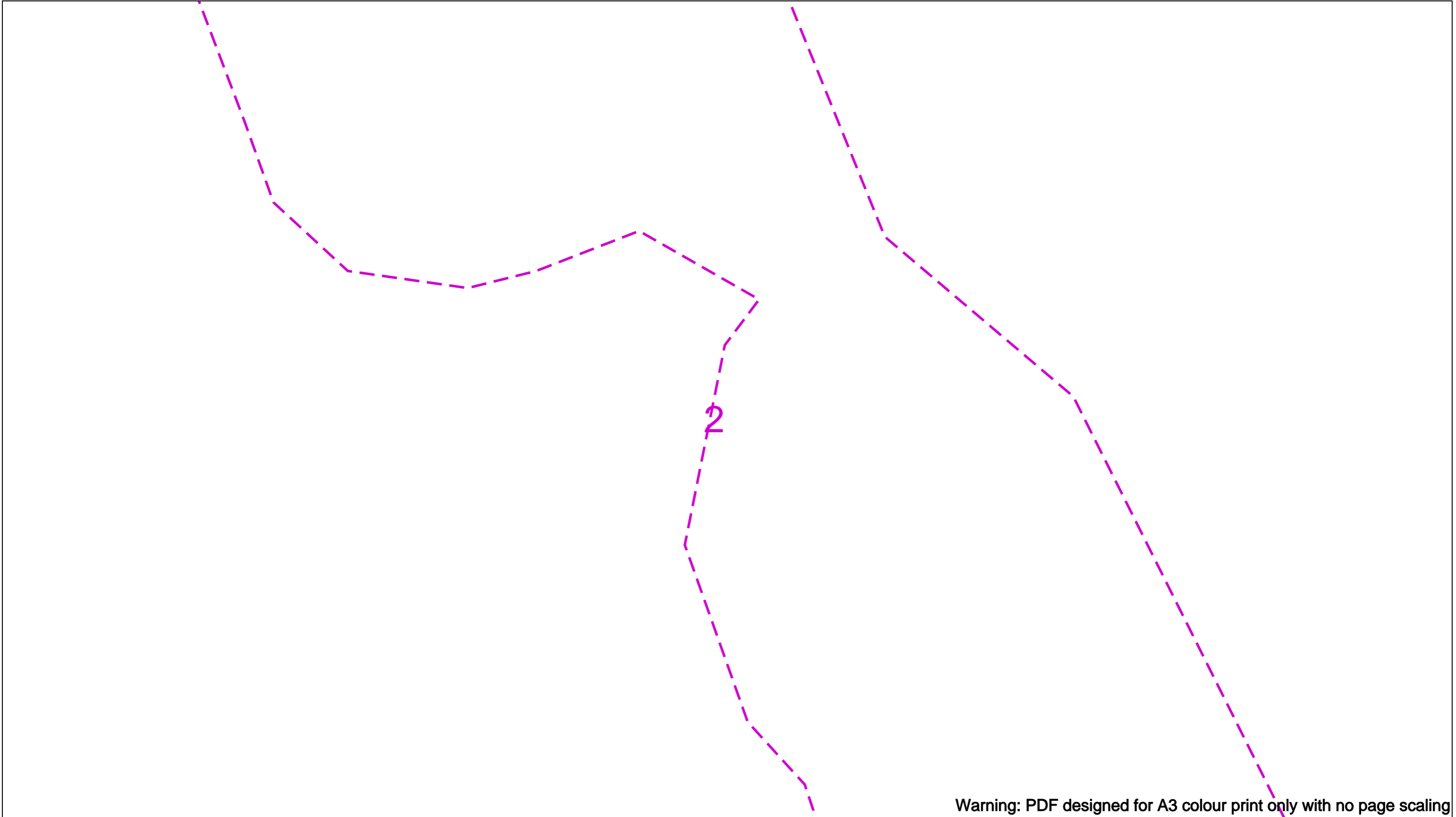

Warning: PDF designed for A3 colour print only with no page scaling

Contact Us
 Mapping Enquiries: 02920 278 912
 General Enquiries: 0800 912 2999

Date Requested: 21/07/2021
 Job Reference: 22745493
 Site Location: 88291 15253
 Requested by:
 Mr Andy Campbell
 Your Scheme/Reference: CAS







Scale: 1:1250 (When plotted at A3)





IMPORTANT NOTICES

- This information is given as a guide only and its accuracy cannot be guaranteed
- The plan only shows those pipes owned by Wales & West Utilities (WWU) as its role as a licensed Gas Transporter
- Service pipes, valves, syphons, stub connections etc. may not be shown but their presence should be anticipated
- You must use safe digging practices in accordance with HS(G)47 to establish the actual position of mains, services and other apparatus before any mechanical excavation is used
- It is your responsibility to ensure this information is provided to all persons working near our plant
- If in doubt call the WWU dig team on 02920 278912

In case of an emergency call 0800 111 999



Dig Sites	Area: 	Line: 
	Low Pressure (LP) 21mbar – 75mbar	
	Medium Pressure (MP) 350mbar – 2bar	
	Intermediate Pressure (IP) 2bar – 7bar	
	High Pressure (HP) >7bar	

	Line/Fire Valve
	Governor Station
	Change of Diameter
	End Cap
	Depth of cover



Dial before you dig

We need 10 days' notice

Smell gas?
 Call the Gas Emergency Service on 0800 111 999.

Dial
 before you start work.
 Call 029 2027 8912

Investigate
 Before you dig, make sure you know what's below.

Go ahead
 Done your research? Now you can dig safely.

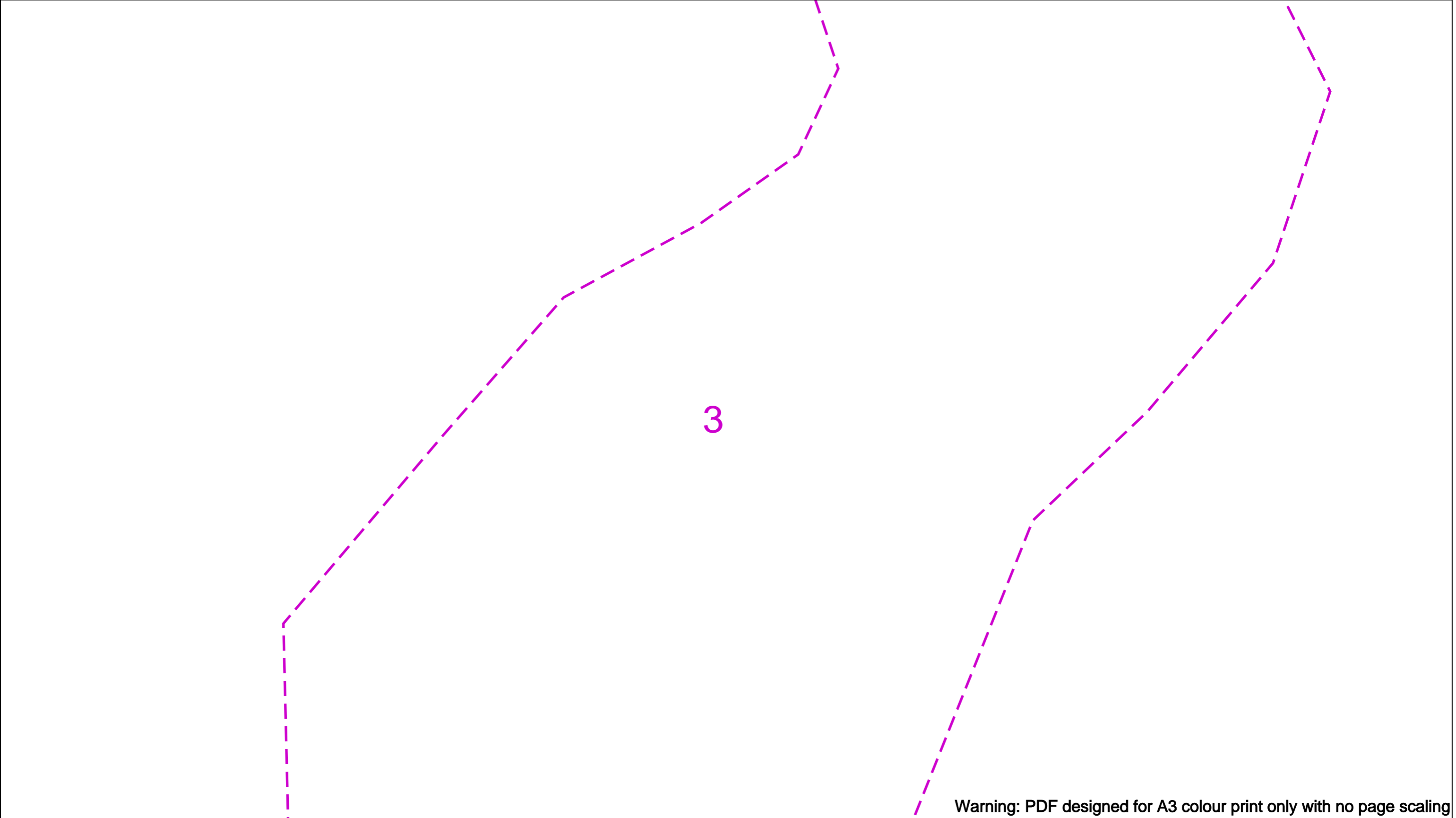

Warning: PDF designed for A3 colour print only with no page scaling

Contact Us
 Mapping Enquiries: 02920 278 912
 General Enquiries: 0800 912 2999

Date Requested: 21/07/2021
 Job Reference: 22745493
 Site Location: 88291 15253
 Requested by:
 Mr Andy Campbell
 Your Scheme/Reference: CAS







Scale: 1:1250 (When plotted at A3)





IMPORTANT NOTICES

- This information is given as a guide only and its accuracy cannot be guaranteed
- The plan only shows those pipes owned by Wales & West Utilities (WWU) as its role as a licensed Gas Transporter
- Service pipes, valves, syphons, stub connections etc. may not be shown but their presence should be anticipated
- You must use safe digging practices in accordance with HS(G)47 to establish the actual position of mains, services and other apparatus before any mechanical excavation is used
- It is your responsibility to ensure this information is provided to all persons working near our plant
- If in doubt call the WWU dig team on 02920 278912

In case of an emergency call 0800 111 999



Dig Sites	Area: 	Line: 
	Low Pressure (LP) 21mbar – 75mbar	
	Medium Pressure (MP) 350mbar – 2bar	
	Intermediate Pressure (IP) 2bar – 7bar	
	High Pressure (HP) >7bar	

-  Line/Fire Valve
-  Governor Station
-  Change of Diameter
-  End Cap
-  Depth of cover



Smell gas?
 Call the Gas Emergency Service on 0800 111 999.

Dial before you dig
 We need 10 days' notice

Go ahead
 Done your research? Now you can dig safely.

Investigate
 Before you dig, make sure you know what's below.

Dial
 Call 029 2027 8912 before you start work.

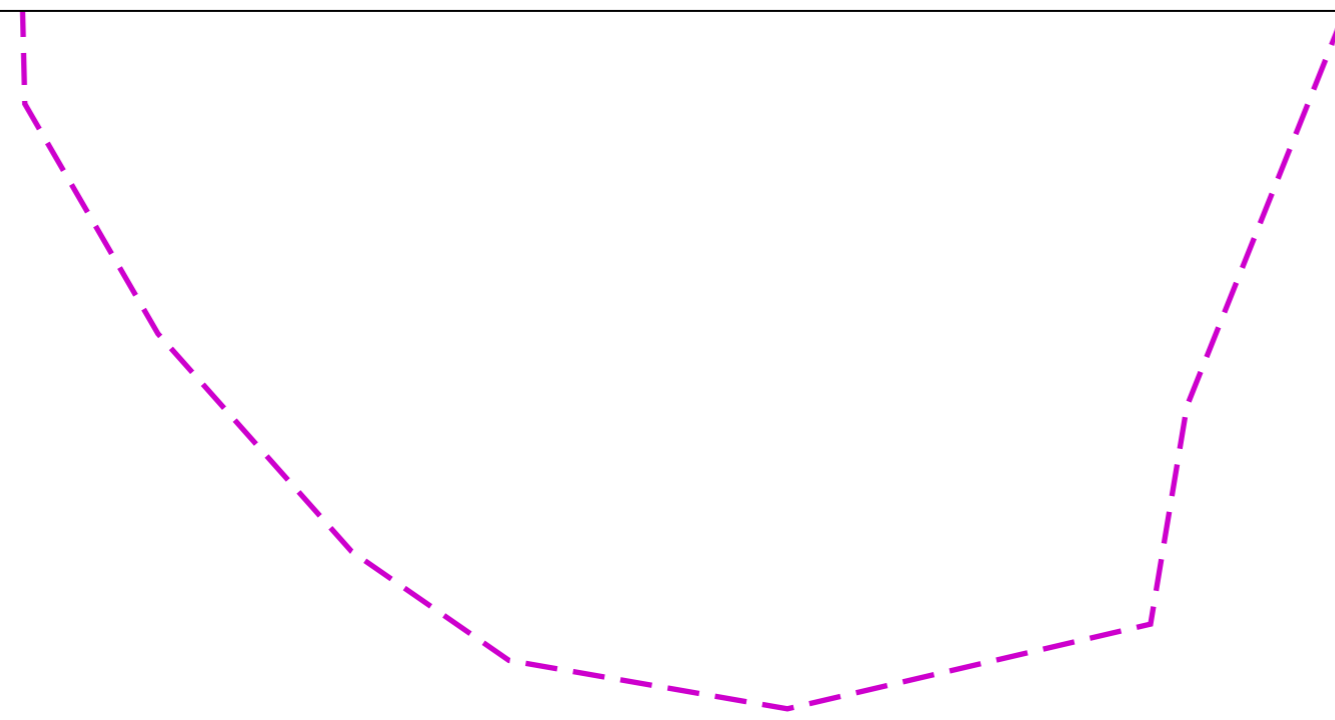

4

Warning: PDF designed for A3 colour print only with no page scaling

Contact Us
 Mapping Enquiries: 02920 278 912
 General Enquiries: 0800 912 2999

Date Requested: 21/07/2021
 Job Reference: 22745493
 Site Location: 88291 15253
 Requested by:
 Mr Andy Campbell
 Your Scheme/Reference: CAS

Scale: 1:1250 (When plotted at A3)

IMPORTANT NOTICES

- This information is given as a guide only and its accuracy cannot be guaranteed
- The plan only shows those pipes owned by Wales & West Utilities (WWU) as its role as a licensed Gas Transporter
- Service pipes, valves, syphons, stub connections etc. may not be shown but their presence should be anticipated
- You must use safe digging practices in accordance with HS(G)47 to establish the actual position of mains, services and other apparatus before any mechanical excavation is used
- It is your responsibility to ensure this information is provided to all persons working near our plant
- If in doubt call the WWU dig team on 02920 278912

In case of an emergency call 0800 111 999



Dig Sites

- Area: Line:
- Low Pressure (LP) 21mbar – 75mbar
- Medium Pressure (MP) 350mbar – 2bar
- Intermediate Pressure (IP) 2bar – 7bar
- High Pressure (HP) >7bar



Line/Fire Valve



Governor Station



Change of Diameter



End Cap



Depth of cover



Dial
before
you dig

We need
10 days'
notice

Smell gas?
Call the Gas Emergency Service on
0800 111 999.

Dial
Call 029 2027 8912
before you start work.

Investigate
Before you dig, make sure
you know what's below.

Go ahead
Done your research?
Now you can dig safely.

F Bills of Quantity

Site	Item Description	Unit	Quantity
1 - Greatpar South	Excavation and stockpile of topsoil	m ³	134
	Bulk excavation, sort material into stockpiles	m ³	1,375
	Surface preparation	m ²	1,625
	Supply and placement of geotextile	m ²	1,848
	Supply and placement of 40-200 kg underlayer	m ³	994
	Supply and placement of 1-3 T rock	m ³	1,063
	Placement of bulk backfill (front of revetment toe)	m ³	77
	Placement of bulk backfill (back of revetment crest)	m ³	364
	Preparation of surface	m ³	440
	Supply and installation of geomat	m ²	528
	Placement of topsoil (back of revetment crest)	m ³	134
	Trimming of surface	m ²	440
	Bulk material remaining	m ³	934
2/3b – Great Porth	Excavation and stockpile of topsoil	m ³	239
	Bulk excavation, sort material into stockpiles	m ³	1,375
	Surface preparation	m ²	1,282
	Supply and placement of geotextile	m ²	1,623
	Supply and placement of 1-3 T rock	m ³	1,767
	Placement of bulk backfill (front of revetment toe)	m ³	75
	Placement of topsoil/site won (back of revetment crest)	m ²	204
	Preparation of surface	m ³	292
	Supply and installation of geomat	m ²	351
	Placement of topsoil (back of revetment crest)	m ²	239
	Trimming of surface	m ²	292
	Flood gate supply & installation	Sum	1.00
	Concrete slab and blocks, supply and placement	Sum	1.00
	Bulk material remaining	m ³	1,096
3 – Stinking Porth	Excavation and stockpile of topsoil	m ³	122
	Bulk excavation, sort material into stockpiles	m ³	740
	Surface preparation	m ²	950
	Supply and placement of geotextile	m ²	1,278
	Supply and placement of 40-200 kg underlayer	m ³	144
	Supply and placement of 1-3 T rock	m ³	800
	Placement of bulk backfill (front of revetment toe)	m ³	120
	Placement of bulk backfill (back of revetment crest)	m ³	75
	Placement of topsoil (back of revetment crest)	m ³	122
	Preparation of surface	m ²	308
	Supply and installation of biomat	m ²	339
	Placement of topsoil (back of revetment crest)	m ²	122
	Trimming of surface	m ²	308
	Bulk material remaining	m ³	253
4 - Great Popplest one	Stockpiling of existing rock	m ³	442
	Preparation of surface	m ²	991
	Placement of stockpiled rock (re-used rock) ¹	m ³	442
	Supply and placement of 1-3 T rock (imported rock)	m ³	442
5 – Kitchen Porth	Rock selection and stockpiling	m ³	-
	Surface preparation	m ²	235
	Placement of stockpiled rock (re-used rock) ²	m ³	-
	Supply and placement of 1-3 T rock	m ³	126
8b – Quay	Excavation	m ³	34
	Stockpile / disposal of fill	m ³	34
	Preparation of profile	m ²	69
	Supply and placement of geotextile	m ²	69
	Supply and placement of 1-3 T rock	m ³	148
9 - North Green Bay	Excavation & stockpile of topsoil	m ³	85.81
	Bulk excavation, sorting material to stockpiles	m ³	72.57
	Surface preparation	m ²	429.04
	Supply and place geotextile	m ²	278.28
	Supply, fill with sorted excavated material and place geobags	no.	225.00
	Geobag fill	m ³	49.50
	Place excavated bulk fill	m ³	23.07
	Supply and place bulk fill ³	m ³	285.38
	Surface preparation for geo mat	m ²	214.52
	Supply and place geo mat	m ²	235.97
	Placement of topsoil	m ²	85.81
Trimming of surface	m ²	214.52	
Bulk Material Balance	m ³	2,317.09	

1 Assume 50% of the rock can be recovered and reused

2 There may be some rock that can be reused but it is assumed that all rock is imported

3 Assumes fill material imported from other site on Bryher

Section	Pay Item No.	Description	Unit	Quantity	Rate	TOTAL (GBP)
1 - Greatpar South	1	MANAGEMENT & SUPERVISION				
	1.1	Head Office Management	%		4%	13,300
	1.2	Construction Management and Supervision	%		4%	13,300
	1.3	Engineering and Documentation	%		5%	16,600
	1.4	Procurement, Inspection and Surveys	%		2%	6,700
	2	PRELIMINARIES				
	2.1	Contract preliminaries	%		5%	16,600
	2.2	Mobilisation / demobilisation Fabrication & Installation Works	%		25%	83,000
	3	CONSTRUCTION				
	3.1	Excavation and stockpile of topsoil	m ³	134	12	1,586
	3.2	Bulk excavation, sort material into stockpiles	m ³	1375	16	22,206
	3.3	Surface preparation	m ²	1625	5	8,270
	3.4	Supply and placement of geotextile	m ²	1848	13	23,239
	3.5	Supply and placement of 40-200 kg underlayer	m ³	994	129	128,258
	3.6	Supply and placement of 1-3 T rock	m ³	1063	129	137,152
	3.7	Placement of bulk backfill (front of revetment toe)	m ³	77	3	265
	3.8	Placement of bulk backfill (back of revetment crest)	m ³	364	3	1,257
	3.9	Preparation of surface	m ³	440	5	2,019
	3.1	Supply and installation of geomat	m ²	528	10	5,333
	3.11	Placement of topsoil (back of revetment crest)	m ³	134	6	771
3.12	Trimming of surface	m ²	440	3	1,414	
SUB-TOTAL CONSTRUCTION						331,768
SUB-TOTAL						481,268
TOTAL - CONTINGENCY - LOCATION FACTOR					30%	625,648

Section	Pay Item No.	Description	Unit	Quantity	Rate	TOTAL (GBP)
2/3b - Great Porth	1	MANAGEMENT & SUPERVISION				
	1.1	Head Office Management	%		4%	11,800
	1.2	Construction Management and Supervision	%		4%	11,800
	1.3	Engineering and Documentation	%		5%	14,800
	1.4	Procurement, Inspection and Surveys	%		2%	5,900
	2	PRELIMINARIES				
	2.1	Contract preliminaries	%		5%	14,800
	2.2	Mobilisation / demobilisation Fabrication & Installation Works	%		15%	44,200
	3	CONSTRUCTION				
	3.1	Excavation and stockpile of topsoil	m ³	239	12	2,820
	3.2	Bulk excavation, sort material into stockpiles	m ³	1,375	16	22,210
	3.3	Surface preparation	m ²	1,282	5	6,521
	3.4	Supply and placement of geotextile	m ²	1,623	13	20,415
	3.5	Supply and placement of 1-3 T rock	m ³	1,767	129	227,899
	3.6	Placement of bulk backfill (front of revetment toe)	m ³	75	3	259
	3.7	Placement of topsoil/site won (back of revetment crest)	m ²	204	3	704
	3.8	Preparation of surface	m ³	292	5	1,340
	3.9	Supply and installation of geomat	m ²	351	10	3,543
	3.1	Placement of topsoil (back of revetment crest)	m ²	239	6	1,370
	3.11	Trimming of surface	m ²	292	3	939
3.12	Flood gate supply & installation	Sum	1	1,900	1,900	
3.13	Concrete slab and blocks, supply and placement	Sum	1	4,500	4,500	
SUB-TOTAL CONSTRUCTION						294,420
SUB-TOTAL						397,720
TOTAL - CONTINGENCY - LOCATION FACTOR					30%	517,036

Section	Pay Item No.	Description	Unit	Quantity	Rate	TOTAL (GBP)
3 – Stinking Porth	1	MANAGEMENT & SUPERVISION				
	1.1	Head Office Management	%		4%	6,600
	1.2	Construction Management and Supervision	%		4%	6,600
	1.3	Engineering and Documentation	%		5%	8,200
	1.4	Procurement, Inspection and Surveys	%		2%	3,300
	2	PRELIMINARIES				
	2.1	Contract preliminaries	%		5%	8,200
	2.2	Mobilisation / demobilisation Fabrication & Installation Works	%		25%	41,000
	3	CONSTRUCTION				
	3.1	Excavation and stockpile of topsoil	m ³	122	12	1,444
	3.2	Bulk excavation, sort material into stockpiles	m ³	740	16	11,944
	3.3	Surface preparation	m ²	950	5	4,833
	3.4	Supply and placement of geotextile	m ²	1,278	13	16,071
	3.5	Supply and placement of 40-200 kg underlayer	m ³	144	129	18,562
	3.6	Supply and placement of 1-3 T rock	m ³	800	129	103,200
	3.7	Placement of bulk backfill (front of revetment toe)	m ³	120	3	414
	3.8	Placement of bulk backfill (back of revetment crest)	m ³	75	3	259
	3.9	Placement of topsoil (back of revetment crest)	m ³	122	3	393
	3.10	Preparation of surface	m ²	308	5	1,413
	3.11	Supply and installation of biomat	m ²	339	10	3,422
3.12	Placement of topsoil (back of revetment crest)	m ²	122	6	702	
3.13	Trimming of surface	m ²	308	3	989	
SUB-TOTAL CONSTRUCTION						163,646
SUB-TOTAL						237,546
TOTAL - CONTINGENCY - LOCATION FACTOR					30%	308,810

Section	Pay Item No.	Description	Unit	Quantity	Rate	TOTAL (GBP)
4 – Great Popplestone	1	MANAGEMENT & SUPERVISION				
	1.1	Head Office Management	%		4%	5,800
	1.2	Construction Management and Supervision	%		4%	5,800
	1.3	Engineering and Documentation	%		5%	7,300
	1.4	Procurement, Inspection and Surveys	%		2%	2,900
	2	PRELIMINARIES				
	2.1	Contract preliminaries	%		5%	7,300
	2.2	Mobilisation / demobilisation Fabrication & Installation Works	%		25%	36,200
	3	CONSTRUCTION				
	3.1	Stockpiling of existing rock	m ³	442	9	3,914
	3.2	Preparation of surface	m ²	991	79	78,695
	3.3	Placement of stockpiled rock (re-used rock)	m ³	442	11	5,081
	3.4	Supply and placement of 1-3 T rock (imported rock)	m ³	442	129	57,053
	SUB-TOTAL CONSTRUCTION					
SUB-TOTAL						210,043
TOTAL - CONTINGENCY - LOCATION FACTOR					30%	273,055

Section	Pay Item No.	Description	Unit	Quantity	Rate	TOTAL (GBP)
5 – Kitchen Porth	1	MANAGEMENT & SUPERVISION				
	1.1	Head Office Management	%		4%	1,400
	1.2	Construction Management and Supervision	%		4%	1,400
	1.3	Engineering and Documentation	%		5%	1,800
	1.4	Procurement, Inspection and Surveys	%		2%	700
	2.0	PRELIMINARIES				
	2.1	Contract preliminaries	%		5%	1,800
	2.2	Mobilisation / demobilisation Fabrication & Installation Works	%		25%	8,800
	3.0	CONSTRUCTION				
	3.1	Rock selection and stockpiling	m ³	0	9	0
	3.2	Surface preparation	m ²	235	79	18,661
	3.3	Placement of stockpiled rock (re-used rock)	m ³	0	11	0
	3.4	Supply and placement of 1-3 T rock	m ³	126	129	16,284
	SUB-TOTAL CONSTRUCTION					
SUB-TOTAL						50,845
TOTAL - CONTINGENCY - LOCATION FACTOR					30%	66,098

Section	Pay Item No.	Description	Unit	Quantity	Rate	TOTAL (GBP)
8b - Quay	1	MANAGEMENT & SUPERVISION				
	1.1	Head Office Management	%		4%	900
	1.2	Construction Management and Supervision	%		4%	900
	1.3	Engineering and Documentation	%		5%	1,100
	1.4	Procurement, Inspection and Surveys	%		2%	500
	2	PRELIMINARIES				
	2.1	Contract preliminaries	%		5%	1,100
	2.2	Mobilisation / demobilisation Fabrication & Installation Works	%		25%	5,400
	3	CONSTRUCTION				
	3.1	Excavation	m ³	34	12	406
	3.2	Stockpile / disposal of fill	m ³	34	4	153
	3.3	Preparation of profile	m ²	69	12	816
	3.4	Supply and placement of geotextile	m ²	69	13	865
	3.5	Supply and placement of 1-3 T rock	m ³	148	129	19,092
	SUB-TOTAL CONSTRUCTION					
SUB-TOTAL						31,232
TOTAL - CONTINGENCY - LOCATION FACTOR					30%	40,601

Section	Pay Item No.	Description	Unit	Quantity	Rate	TOTAL (GBP)
9 - North Green Bay	1	MANAGEMENT & SUPERVISION				
	1.1	Head Office Management	%		4%	1,900
	1.2	Construction Management and Supervision	%		4%	1,900
	1.3	Engineering and Documentation	%		5%	2,300
	1.4	Procurement, Inspection and Surveys	%		2%	1,000
	2	PRELIMINARIES				
	2.1	Contract preliminaries	%		5%	2,300
	2.2	Mobilisation / demobilisation Fabrication & Installation Works	%		25%	11,500
	3	CONSTRUCTION				
	3.1	Excavation & stockpile of topsoil	m ³	86	12	1,013
	4.1	Bulk excavation, sorting material to stockpiles	m ³	73	16	1,172
	5.1	Surface preparation	m ²	429	5	2,183
	6.1	Supply and place geotextile	m ²	278	13	3,499
	7.1	Supply, fill with sorted excavated material and place geobags	no.	225	136	30,600
	8.1	Geobag fill	m ³	50	3	171
	9.1	Place excavated bulk fill	m ³	23	3	80
	10.1	Supply and place bulk fill	m ³	285	7	1,969
	11.1	Surface preparation for geo mat	m ²	215	7	1,429
	12.1	Supply and place geo mat	m ²	236	10	2,383
13.1	Placement of topsoil	m ²	86	6	492	
14.1	Trimming of surface	m ²	215	3	689	
SUB-TOTAL CONSTRUCTION						45,680
SUB-TOTAL						66,580
TOTAL - CONTINGENCY - LOCATION FACTOR					30%	86,554

G Product Information

G.1 Geotextile

Coastal and River Defence Systems: Design Guidance

hps
HIGH PERFORMANCE SQUARE

GEOfabrics[®]



Quality

High Performance

Easy Installation

Mechanical Strength

Construction Cost Savings

Value Engineering

Long Term Durability

About Us

GEOfabrics Limited is the UK's leading manufacturer of geotextiles. Since its formation in 1992, millions of square metres of HPS geotextile have been deployed along coastlines and watercourses beneath rock armour and prefabricated concrete units.

The company's ethos is to continually exceed the expectations of both existing and future customers with innovative and effective products supported by an established technical service. Successful product development is achieved by understanding the customer's problem, determining the necessary properties and functions that are required,

manufacturing the solution and then rigorous quality testing to demonstrate that the product meets those requirements. GEOfabrics has a dedicated and experienced team of personnel that cover both commercial and technical departments and that work in unison to provide the necessary attributes to meet our global challenges.

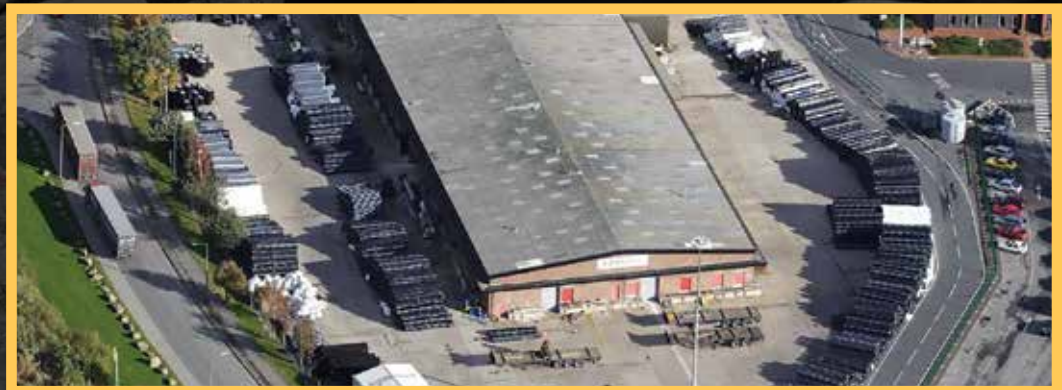

Coastal Defence Structures Using HPS Geotextiles

For many years GEOfabrics have developed and provided a broad spectrum of tailored engineering HPS products that are specifically manufactured to address the many problematic challenges of coastal/river defence and erosion.

HPS Geotextiles Coastal Applications

- Artificial Islands
- Beaches
- Bridge Abutments
- Revetments
- River Protection
- Flood Bunds
- Harbours
- Lagoons, Lakes & Reservoirs
- Land Reclamation Offshore
- Wind Generators
- Rock Groynes
- Scour Control
- Submerged Breakwaters
- Coastal Defence

GEOfabrics HPS filter/separators have been designed to provide sustained permeability whilst maintaining structural stability. They provide excellent filtering efficiency, a high level of stress absorption and are highly resistant to abrasion.

Quality in Manufacturing

GEOfabrics Limited is the UK's leading manufacturer of geotextiles. Since its formation in 1992, millions of square metres of HPS geotextile have been deployed along coastlines and watercourses beneath rock armour and prefabricated concrete units. Their use is due to the quality of the products, their cost effectiveness and the comprehensive help provided to design engineers and contractors at every stage of a project.

Quality in Service

The HPS products have been designed and are manufactured to meet the most demanding performance levels. Using a modern computer-controlled plant, all products are manufactured in an ISO9001 environment and sampled and tested to the appropriate standards.



▲ Typical primary rock armour revetment installation directly on HPS geotextile. Location: Colwyn Bay.

HPS Solutions – Preventing Erosion

The insidious effects of wave action and high-velocity water flow are a permanent reminder that the environment cannot be tamed. HPS geotextiles offer long-term protection against erosion in some of the most aggressive environments.

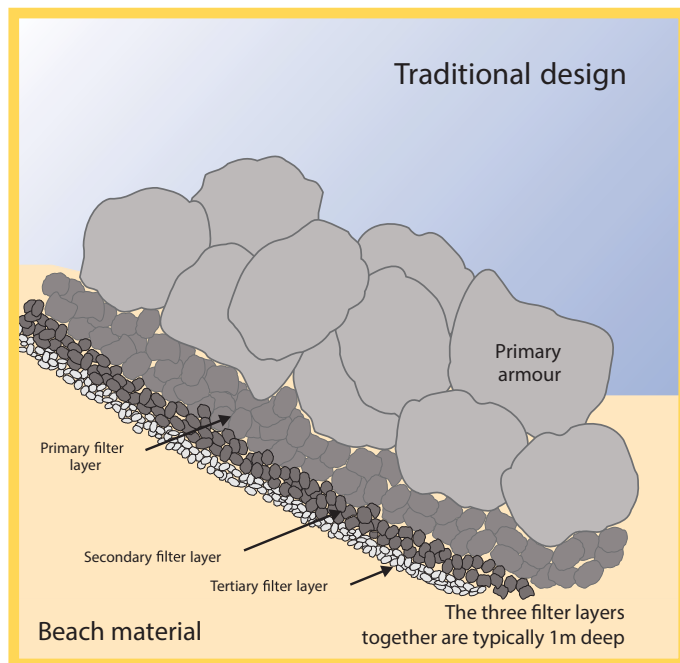

A graded stone filter is a complex, time-consuming and costly installation.

On one hand, storms and flash flooding cause high-profile failures, but a slow-moving, low-level stream is just as capable of undercutting its banks and causing slope instability.

Protection to combat erosion currently tends towards soft and natural solutions including beach nourishment and rock armour, the size of which is determined by the anticipated wave or erosional scour action. Filter layers are required beneath rock armour to prevent erosion of the underlying soil. Otherwise, the armour would progressively drop into the increasing void and its effectiveness would be diminished.

Historically, graduated granular filter layers, with progressively larger grain size, were used to prevent this type of erosion.

Installation was time-consuming and they could be difficult to install, particularly if this involved inter-tidal working.

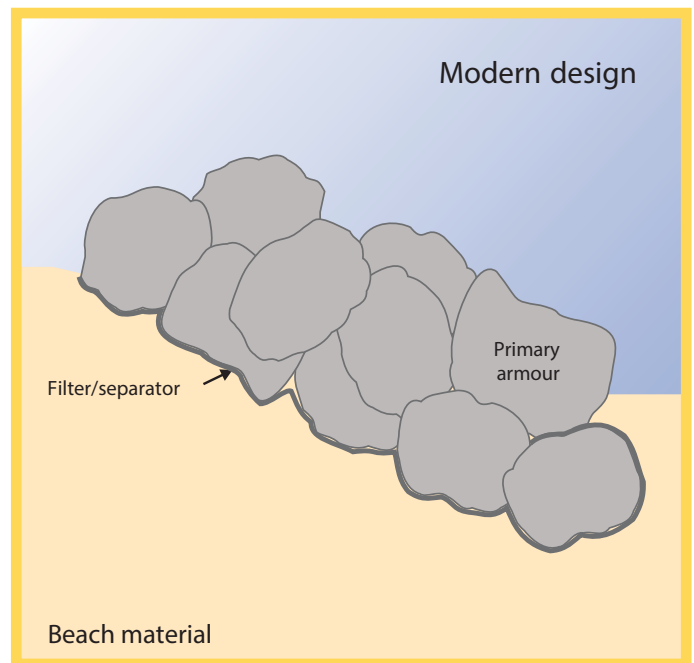

A high strength HPS geotextile replaces a multilayered stone filter system and is quicker to install when battling the tides.

The environmental impact of importing thousands of tonnes of stone of the required gradings, often with restricted access, and their expense, meant that there was scope for alternative solutions.

Revetments constructed from rock armour or pre-cast concrete units require a filter to prevent mobilisation of underlying soil and to allow the free movement of water in both directions.

Without the ability to provide these functions over the entire life of the revetment, there is the potential for the armour to be undermined, as beach material is progressively eroded, or for a build up in hydrostatic pressure.

Of equal importance is the ability of the HPS filter/separator to withstand the rigours of installation and the in-service conditions. Materials susceptible to puncture, tearing and abrasion would exclude them from consideration.

HPS needlepunched, non-woven geotextiles provide all of the required functionality at the levels demanded for erosion prevention applications.



Case Study: Yas Island Race Track Marina, Abu Dhabi, UAE.

hps HIGH PERFORMANCE SQUARE

- Our established HPS range of materials for construction consists of high performance geotextiles manufactured from high quality, high tenacity, 100% virgin polypropylene fibres.
- Oxidation tests indicate in excess of 150 years durability, as demonstrated on our product CE declarations.
- With a capability to manufacture up to a maximum width of 6m, GEOfabrics' HPS needlepunched geotextiles are specified by engineers due to their longevity and proven ability to work in the most demanding installations.
- High static and dynamic puncture resistance.
- High elongation to break.
- Superior abrasion resistance.
- Excellent filtration characteristics at all strains.
- UV resistance – 1% carbon black.
- Light weight and easy to handle.

Selecting the Most Appropriate HPS Grade

There is a diversity of geotextile types available. To make the appropriate selection a design engineer needs to match their functions and properties with the requirements of the project, to ensure the selected geotextile is both fit for purpose and will function as intended for the design lifetime.

Permeability

Classic filter rules state that each layer of a filter system must be more permeable than the layer beneath. Similar rules developed for geotextiles suggest a coefficient of permeability 10 to 100 times greater than that of the filtered soil. It is important that the geotextile should maintain or exceed its index permeability whilst under load, i.e. any re-orientation of the fibres should not increase or decrease permeability.

Filtration

The characteristic pore size of the geotextile has to be less than the average grain size of the soil to be filtered in order to prevent loss of material through the geotextile. Established design rules for reversing flow applications and a non-cohesive soil state that the geotextile's O_{90} should be less than the d_{50} of the soil to be filtered. For a cohesive soil, $O_{90} < 10 \times d_{50}$.

Both the permeability and filtration rules apply factors of safety to allow for reductions in these properties by soil particles clogging within the geotextile. A filter will be regularly flushed if the system is subject to reversing flows, thus minimising any reduction in filtering efficiency.

Static and Dynamic Puncture Resistance

The geotextile must be able to withstand puncture loads imposed during installation and service. The rock weight, its angularity and the drop height all contribute to puncture load. This can be further intensified if due care is not taken during installation. Ideally, it will also possess isotropic (square) tensile properties in order to spread load consistently in all directions.

Elongation

Rock armour functions by virtue of its dead weight being transmitted over as wide an area as possible to consolidate the underlying soil and minimise particle movement. The load imposed on a geotextile by large rock is not evenly distributed. The highest stress concentration will be at the point of intimate contact which in turn will impose high localised strains. The geotextile needs to be sufficiently extensible to enable it to adapt to point loads without puncturing and without loss of hydraulic properties.

Thickness

Thickness is required to cushion potentially penetrating point loads and also to provide a lateral drainage path around any compressed areas. Lateral drainage capacity is defined by the geotextile's in-plane flow under load.

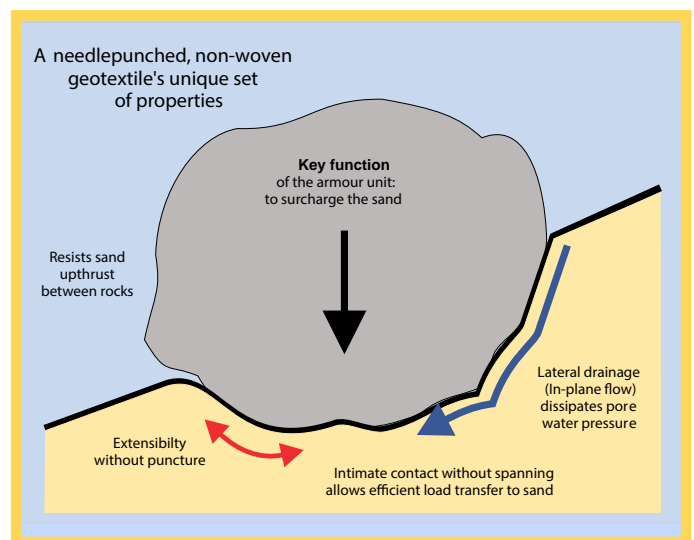

High elongation of HPS geotextile under aggressive rock armour loading.

Classic filter rules state that each layer of a filter system must be more permeable than the layer beneath. Similar rules developed for geotextiles suggest a coefficient of permeability 10 to 100 times greater than that of the filtered soil.



Case Study: Hulayla Marina Development. HPS filter/seperator geotextiles preventing intermixing of fill layers behind quay wall structure.

Whilst standard index tests do not exactly simulate the performance of the filter/seperator there needs to be some rationale for the specification. HPS geotextiles are manufactured such that the following key properties are maximised for coastal and river applications. A model specification should address the following properties:

- **Water Flow Normal to the Plane**
Closely linked to permeability. Very important in dynamic, high-flow applications.
- **Pore Size**
Defines the opening size of a geotextile and its ability to trap particles and prevent their passage.
- **Minimum Tensile Extension**
Placing rock is potentially the greatest cause of damage and the extensibility of a geotextile is important to avoid localised damage.
- **Static Puncture Resistance (CBR)**
Simulates the in-situ punching effect of rock, normal to a geotextile, during service.
- **Dynamic Perforation Resistance (Cone Drop)**
Indicates the ability of a geotextile to accommodate dynamic puncture during rock placement.
- **Coefficient of Permeability**
Related to the thickness of a geotextile. Expresses water flow as a k_g value allowing comparison with soil values (k_s).
- **Tensile Strength**
Simulates a geotextile's ability to be handled on-site using heavy excavators. It is common for operators to spread and unroll the geotextile using the bucket of an excavator.
- **Push-through Displacement**
Simulates biaxial strain caused by rock placed on the geotextile, and the capacity to resist localised damage.
- **Thickness Under Load**
Ensures that there is a water path beneath the stone allowing dissipation of pore water pressure.

HPS Durability Considerations

DURABILITY CONSIDERATIONS

Short Term: Construction

- UV stabilised to reduce effects of photo-chemical degradation while exposed.
- High isotropic mechanical performance to withstand puncture and extension during installation. HPS geotextiles are isotropic by manufacture ensuring optimum extension and puncture resistance to withstand abnormal rock armour shapes.

Long Term: Design Life

- Chemically resistant to the environment – both fresh and salt water.
- 100% virgin polypropylene used in HPS manufacture is generally considered inert.
- Mechanically resistant to the environment – able to withstand cyclic loading of tidal action.
- HPS geotextiles have mechanical extensibility up to 80%.

Example Section: Coastal Defence Revetment

[NATURAL DEPOSITS]

Application specific durability demands.

Raw Material

Fabrics can be produced from both post-industrial and post-consumer recycled fibres. Such fibre types can be of different thicknesses, and volume to surface ratios. Some types of degradation, such as oxidation and UV exposure, are dependent on surface area, whilst others such as diffusion and absorption are inversely related to thickness. It is strongly advised that the use of post-industrial/post-consumer fibre is avoided.

Another polymer fibre that is used within geotextile manufacturing is polyester, of which the most common type is polyethylene-terephthalate (PET) which is produced using condensation polymerisation. PET can offer good mechanical properties and is suitable for some applications, however the ester group can be hydrolysed in the presence of water which is accelerated by alkaline conditions such as salt water. Although polyester can have advantages over other polymers the alkaline sensitivity of this polymer through hydrolysis under long-term loadings, should be a major concern in coastal geotextile applications.

GEOfabrics' HPS range is manufactured from 100% virgin, staple length, high tenacity polypropylene fibres which have a high resistance to acids, alkalis and most solvents. Polypropylene can be considered as inert to acid and alkali attack and is suitable for most geotextile applications.

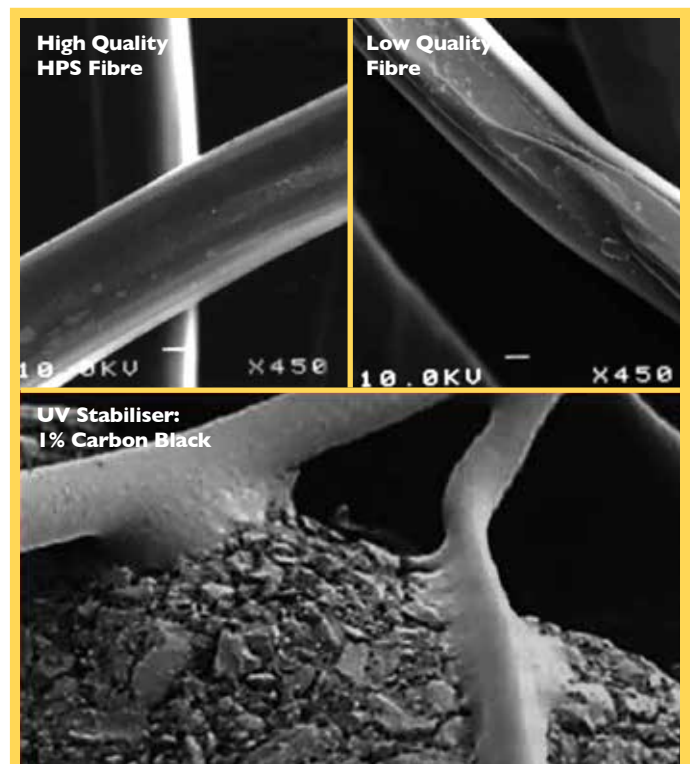

High resolution images of fibre morphology. GEOfabrics 'thinking about the fine detail'.

The Design Mechanism

The type of polymer and the fibre, together with the production process, define the inherent properties of a geotextile. GEOfabrics' needlepunched, non-woven geotextiles are manufactured using specially engineered fibres and these are bound to each other by mechanical needling.

The balance between hydraulic and mechanical properties is optimised for:

- High permeability with fine filtration.
- Good cushioning ability and impact resistance.
- High isotropic puncture resistance with high strains to failure.
- Good water flow performance.

Design methodology will consider whether the primary armour is to be placed directly or indirectly on the filter/separator. Armour can be placed directly on top of the HPS products so there is no need for an intermediate bedding layer of stone.

Step by Step Specification Procedure

STEP 1

Establish the primary armour weight from wave height predictions.

ROCK WEIGHT EXAMPLE:

4t Maximum Armour Size.

STEP 2

Establish the type and permeability of the underlying soil.

Table 1

Soil type	Filtration d_{50} (mm)	Permeability k_s (m/s)
Clayey silt	0.02	1×10^{-9}
Sandy silt	0.02	1×10^{-7}
Fine sand	0.30	1×10^{-5}
Coarse sand	0.50	1×10^{-4}
Mixed sand & shingle	2.00	1×10^{-3}

STEP 3

Provisionally select an HPS grade based upon its permeability e.g. if soil permeability is 10^{-5} m/s then the grade must have a permeability $>10^{-4}$ m/s.

PERMEABILITY EXAMPLE:

Beach material is fine sand with a permeability (k_s) = 1×10^{-5} m/s.

The filter/separator should have a permeability (k_g) $>10 \times$ permeability of soil.

Therefore, geotextile k_g should be $> 1 \times 10^{-4}$ m/s.

- GEOfabrics' HPS filter/separators are in the range 3×10^{-3} m/s to 10×10^{-3} m/s.

STEP 4

Check that the grade's $O_{90} < d_{50}$ of the subsoil.
This requirement is satisfied by most of the HPS product range.

FILTRATION EXAMPLE:

d_{50} of fine sand is typically 0.3mm (see Table 1). The filter/separator O_{90} must be $< d_{50}$.
For d_{50} of 0.3mm – required O_{90} must be < 0.3 mm.

■ GEOfabrics' geotextiles have an O_{90} in the range 0.2mm to 0.07mm.

STEP 5

Check that the selected grade can withstand installation loading without puncture.

INSTALLATION DAMAGE RESISTANCE EXAMPLE:

FOS against damage = 3.0.

Maximum likely drop height = 1.5m.

Maximum rock size in contact with geotextile = 4000kg.

Rock drop energy = $1.5 \times 4000 = 6000$ kgm. From installation damage graph below.

■ GEOfabrics HPS14 would be suitable in this instance.

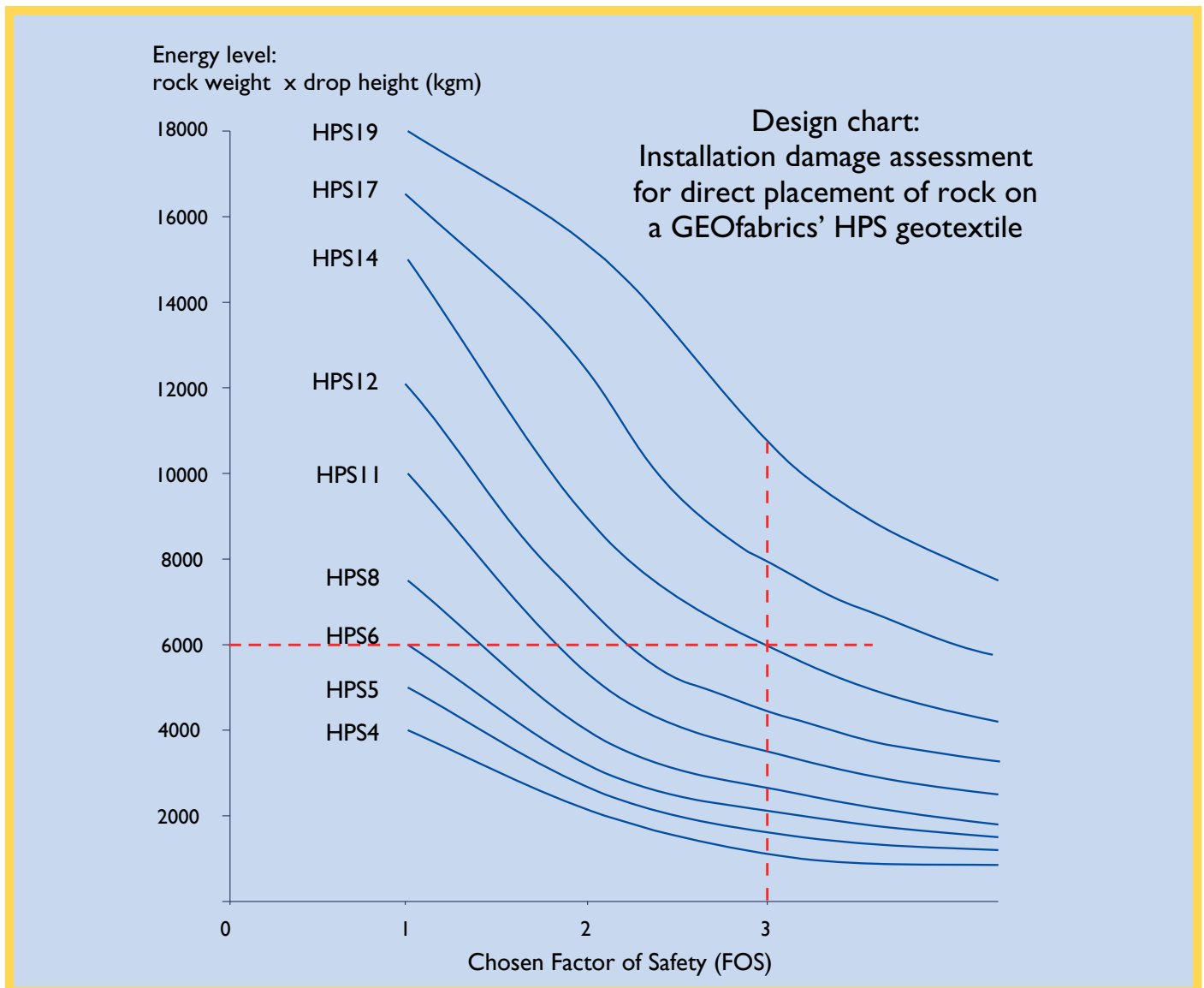

STEP 6

Check that there is sufficient design elongation for the fabric to function without tearing. Assuming rock diameter is approx 1.5m, and the rock is depressed into subsoil to a third of its depth, i.e. 0.5m, the localised elongation in the geotextile due to the friction between subsoil and rough edges of the rock could be as much as 20%. To allow a FOS = 3, a minimum tensile extension would therefore be 60%.

ELONGATION EXAMPLE:

FOS against damage = 3.0.

Maximum likely rock diameter = 1.5m (OD).

Depression depth 0.5m ($\frac{1}{3}$ rd OD).

Elongation approx. $20\% \times \text{FoS } 3.0 = 60\%$ elongation required (Tensile Extension).

■ GEOfabrics' HPS14 would be suitable in this instance.



▲ Live Installation: 3t rock armour dropped from 2m height onto HPS14 overlying a sandy clay unconsolidated beach deposit.

Specification Considerations

A well-written specification for a filter/separator is of paramount importance as there are many geotextile types available with widely varying physical characteristics and production qualities. Testing and quality assurance is as important for geotextiles as it is for other materials incorporated in the works.

British Standard (BS) and European (EN) index tests are available to enable engineers to compare one geotextile with another. These tests and quality control schemes need to be referenced in the specification (**see example specification below**).

The tests should then be used to assess the suitability of a proposed geotextile for the works. The manufacturer's

Quality Control procedures should be made available and a Certificate of Conformance should cover each consignment. Additional samples may be taken from each consignment, by the contractor, to be tested as directed by the engineer.

As an example, a performance specification is provided based on HPS14 – the product identified in the worked example.

2.1 Physical Properties:				
Polymer type:	Prime-quality virgin polypropylene fibre containing 1% carbon black by weight.			
Geotextile type:	Needlepunched non-woven fabric manufactured from mechanically entangled staple fibre.			
	Approved test method	Units	Typical mean value	Allowable tolerance to 95% confidence limits
Thickness @ 2kPa:	EN ISO 9863-1: 2005	mm	7.8	n/a*
2.2 Mechanical Properties:				
Static puncture strength (CBR)	EN ISO 12236	kN	14	-10%
Push-through displacement	EN ISO 12236	mm	65	n/a*
Tensile strength	EN ISO 10319	kN/m	75	-10%
Tensile elongation	EN ISO 10319	%	80	+/-30%
Cone drop perforation hole diameter	BS EN 13433	mm	0	+3mm
2.3 Filtration Properties:				
Water flow normal to the plane of the geotextile @50mm head	EN ISO 11058	l/s/m ²	25	-30%
Characteristic opening size: 90% finer [O ₉₀]	EN ISO 12956	µm	<69	+/-30%

* Indicates property not used for quality control as part of harmonised testing within EN 13253.

2.4 Durability (according to annex B: EN 13253):			
Resistance to weathering (UV) @ 50MJ/m ² radiant exposure	EN 12224	Retained strength	>80%
Resistance to oxidation (150 years)	EN 13438	Retained strength after 84 days	>80%
Microbiological resistance	EN 12225	Retained strength	>80%
Resistance to liquids	EN 14030	Retained strength	>80%

* Durability test data can be supplied by the manufacturer – test frequency must not exceed 3 years.

Model specifications are available to download from www.geofabrics.com

Performance Specification

- The geotextile to be used as a filter/separator beneath the rock armour shall be a non-woven fabric manufactured by needlepunching virgin, staple fibres of polypropylene incorporating a minimum of 1% by weight active carbon black. Geotextiles manufactured from fibres of more than one polymer will not be permitted.

- The geotextile shall have the following properties:

- Geotextiles shall be delivered to site in packaging, which will protect the rolls from ultra-violet light degradation. The labelling shall clearly identify the product supplied in accordance with **BS EN 10320: 1999**. Geotextiles shall be protected at all times against physical or chemical damage. Geotextiles shall be kept in the wrappings provided by the manufacturer until required for use in the works.
- The geotextile manufacturer shall provide production test certificates at the rate of one set of certificates per 6,000m² delivered to site and a minimum of one set per contract. Test methods employed shall be in accordance with the requirements of **BS EN ISO 13253:AI 2005** and be accredited by UKAS to carry out the required tests. Certificates relevant to a batch of geotextile shall be furnished to the engineer prior to that batch of geotextile being incorporated in the works.
- The rolls of geotextile shall be stored on level ground and stacked not more than five rolls high and no other materials shall be stacked on top of the geotextiles.
- The geotextile shall not be exposed to direct sunlight for longer than thirty days.
- The geotextile shall be laid and installed in the positions and to the line and levels described on the drawings. Material, which will be in contact with the geotextile, shall not have protrusions which are likely to damage the geotextile during installation or in service. Construction plant must not operate directly on the geotextile.
- Joints shall be formed by overlapping by a minimum of 1000mm. A reduction in overlap to 300mm may be considered by the engineer where the sub-layer is firm and above water level.

The following definitions shall apply when considering test results:

A set of test results shall be those results derived from specimens cut from one sample. The *mean value* for any set of test results shall be the arithmetic mean of that set of results.

The *characteristic value* is the value below which not more than 5% of the test results may be expected to fall. This represents the value at 1.64 standard deviations below the mean value.



Rock armour Groyne installation to inhibit 'Long Shore Drift' and protect the coastline.

Installation Guidance

The high strain capacity of the HPS products may be used to advantage when designing anchoring and edge details. Wrapping around a run of small stone or bedding stone, if available, is a proven toe detail. At the top of the revetment the geotextile should be anchored in a trench or fixed to a structure such as a sheet-piled wall. The sides should be treated in a similar fashion for the permanent works and suitable precautions taken to protect them at high tides during the progress of the works.

Joints

HPS geotextiles are produced up to 6m wide to minimise overlaps. Unbonded overlaps should be between 300mm and 1000mm (at the discretion of the engineer) depending upon the firmness of the underlying soil and the relative ease of working.

300mm overlaps are acceptable for above-water working on firm subsoil and 1000mm overlaps are recommended for under water working on soft silts.

Contractors placing the HPS products under water often prefer to joint and re-roll the product onto a metal core. This enables widths up to 12m to be pre-fabricated prior to installation.

Joints can be made by sewing a prayer seam using a bag-closing, handheld sewing machine. This procedure can achieve joints with 60% of the geotextile's strength.

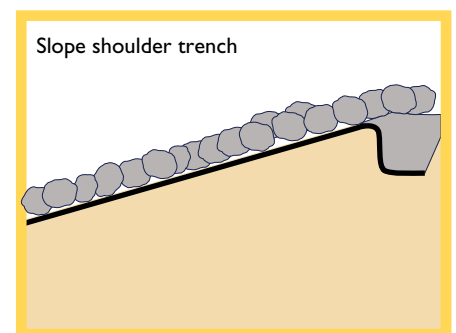
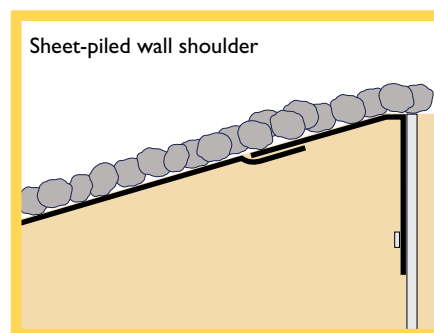
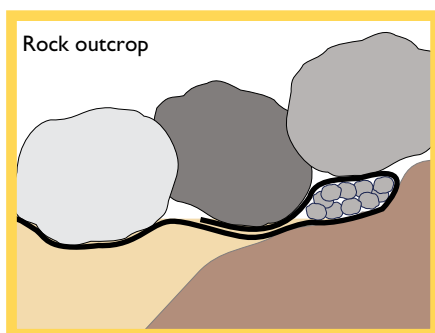
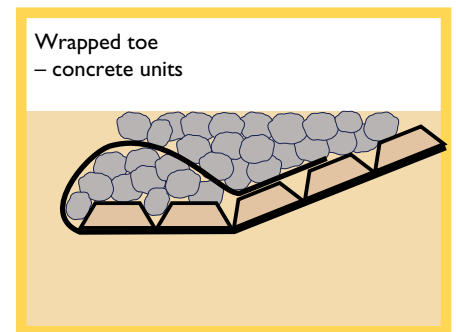
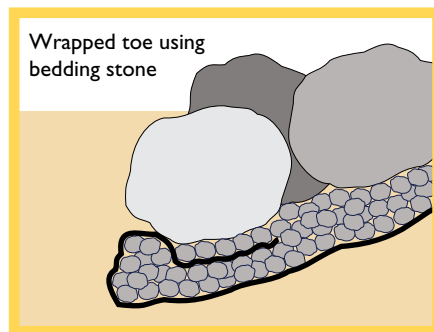
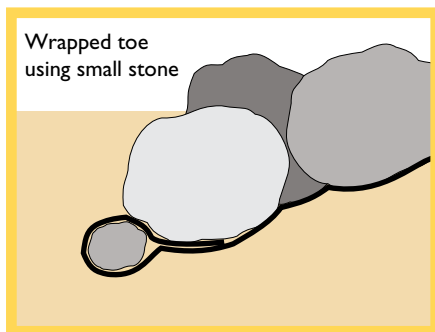

Typical HPS installation details. For further site specific installation details, please contact the GEOfabrics' technical team for assistance.

Quality and Development

GEOfabrics continue as one of the main geosynthetic innovators in the industry with our highly active Research and Development department.



Our continued success in new products is as a result of an experienced team and our ongoing relationships with an expanding list of professional clients who partner with us to produce bespoke geosynthetic solutions.

GEOfabrics' priority is to manufacture a high quality end product that provides the exact needs of our customers, in line with function, durability, value and in accordance with all current legislation and design standards.

▲ GEOfabrics has an extensive laboratory and test facilities. We have a wide range of UKAS accredited tests used for quality control and research and development.

◀ Mechanical testing equipment for tensile strength and elongation.

HPS: Long-Term Durability

GEOfabrics manufacture from 100% virgin staple polypropylene fibre including 1% carbon black. Such fibres are generally considered chemically and biologically inert, in all but the most aggressive environmental applications.

GEOfabrics' HPS geotextiles are resistant to chemical and biological clogging, have UV stability to prevent degradation when exposed to sunlight and provide long-term strength without reduction in performance or function.

GEOfabrics' innovative products are produced using the latest manufacturing technology and UKAS accredited testing facilities.

Should you require any information or assistance in relation to this support service please contact us on +44 (0)113 202 5678.

Accreditations



The ISO 9001 Management system uses customer feedback, continuous assessment and independent auditing to drive both improvement and the control required for a professional and quality based environment.



Accredited laboratories that operate in line with UKAS methodology, policy and audits to provide accurate performance information.



GEOfabrics Limited manufactures CE Marked products that meet the construction products directive.

Acknowledgements given to Ciria C683 'The Rock Manual':



Global Supply Network

GEOfabrics Limited supply a world class range of engineering products for a diverse set of applications, across the UK and international markets. We pride ourselves on building strong, long-term and mutually beneficial partnerships with our agents and distributors, in order to provide a quality technical supply service to our clients.

UK EUROPE MIDDLE EAST NORTH AMERICA AFRICA ASIA

Further literature, in the form of case studies, design guides, installation procedures, product data sheets and model specifications **can be downloaded from www.geofabrics.com**

GEOfabrics Limited
Skelton Grange Road
Stourton
Leeds
LS10 1RZ
United Kingdom

Tel: +44 (0) 113 202 5678
Fax: +44 (0) 113 202 5655

Email: info@geofabrics.com
Web: www.geofabrics.com



CERTIFICATE NO. FM 31473



1773



0338



International distribution

BELGIUM FINLAND GREECE HONG KONG IRELAND OMAN INDIA ROMANIA
SAUDI ARABIA THE NETHERLANDS TURKEY UNITED ARAB EMIRATES USA BRAZIL

G.2 Geobags

Geobags

Woven fabric with lifting straps

The Geotube® Geobag is a containment product manufactured from engineered fabrics combined with high capacity seams that allow sand or other suitable material to be in-filled. They are engineered to provide strength, durability and soil tightness during installation and operational life. The bags are filled with sand through open top or through inlet fabric sleeve on top of the bags. The resulting filled bag can be easily handled and are used to replace rock for the construction of dyke structures or for erosion protection works.

This range of Geotube® Geobags is manufactured using engineered woven fabric with attached lifting straps for handling and installation convenience on site. They are ideal for constructing dyke structures of a temporary nature or used as core fill material in permanent dyke structures.

Properties of TenCate Geotube® Woven Geobags with Lifting Straps

Properties	Test Method	Unit	GB600 MSS1	GB600 MSS2	GB600 MSS3	GB600 MSS4	
Colour			Black	Black	Black	Black	
Nominal box dimensions (unfilled)							
Width		m	1	1	1.6	2	
Length		m	1	2.5	1.6	3	
Height		m	1	1	1.6	1.5	
Lifting points							
Number of lifting points			4	6	10	10	
Tensile strength per strap	ISO 10321	kN	55	55	55	55	
Fabric							
Wide width tensile strength	MD	ISO 10319	kN/m	200	200	200	200
Wide width tensile strength	CD	ISO 10319	kN/m	200	200	200	200
Strain at nominal tensile strength	MD	ISO 10319	%	10	10	10	10
Strain at nominal tensile strength	CD	ISO 10319	%	10	10	10	10
CBR puncture strength		ISO 12236	kN	22	22	22	22
Abrasion resistance		ASTM D4886	% retained	80	80	80	80
UV resistance (at 500 hours)		ASTM D4355	% retained	90	90	90	90
Pore size O_{90}		ISO 12956	mm	0.35	0.35	0.35	0.35
Water permeability Q_{90}		ISO 11058	l/m ² /s	20	20	20	20

Other bag sizes tailored to project requirements may be available upon request.

TenCate Geotube® is a registered trademark of TenCate Geosynthetics.

The values given are indicative and correspond to average values obtained in accredited testing laboratories and institutes.

Further details of this application and products can be obtained by contacting your nearest TenCate Technical Support office. Unauthorized reproduction and distribution is prohibited. This document is provided as supporting service only. The information contained in this document is to the best of our knowledge true and correct. No warranty whatsoever is expressed or implied or given. Engineers wishing to apply this information shall satisfy themselves on the validity of the input data relative to the applicable soil and engineering conditions and in doing so assume design liability.

G.3 Geomattting

Robulon PP

Technical Data

TenCate Geolon® Robulon PP is a high strength geocomposite for erosion control purposes. The product is made of 100% highly durable and UV resistant PP, with a 3 dimensional structure. The combination of reinforcement and soil retention makes Robulon the ideal mat for erosion control in a variety of applications such as protection of slopes, geomembranes, canal and river beddings, and shorelines.



TenCate Geolon® Robulon PP

Characteristics <small>Standard</small>	Unit	PP 40	PP 60	PP 80	
Type of product		Geocomposite made of 100% polypropylene, consisting of a high strength woven base layer featuring inseparable loops for soil, gravel or concrete retention			
Product Properties					
Mass per unit area <small>[EN ISO 9864]</small>	g/m ²	510	580	675	
Thickness under 2kPa <small>[EN ISO 9863-1]</small>	mm	10	10	10	
UV resistance (retained tensile strength) <small>[EN ISO 12224]</small>	%	> 80	> 80	> 80	
Base Layer Properties					
Tensile strength <small>[EN ISO 10319]</small>	MD*	kN/m	40	63	84
	CD*	kN/m	40	57	84
Elongation at maximum strength <small>[EN ISO 10319]</small>	MD*	%	17	8	8
	CD*	%	12	8	8
CBR puncture resistance <small>[EN ISO 12236]</small>		kN	4	6	8
Dynamic perforation <small>[EN ISO 13433]</small>		mm	15	10	9
Forms of supply					
Width	m	5	5	5	
Length	m	45 / 50	50	50	
Roll diameter	m	0.78 / 0.8	0.85	0.85	
Roll weight <small>[indicative]</small>	kg	125 / 140	160	180	

* MD = Machine Direction CD = Cross Direction

The values given are average values obtained in our laboratories and in testing institutes. The right is reserved to make changes without notice at any time..

TENCATE GEOSYNTHETICS AUSTRIA GMBH

Schachermayerstr. 18 Tel. +43 732 6983 0, Fax +43 732 6983 5353
A-4021 Linz, Austria service.at@tencategeo.com, www.tencategeo.at

BeNeLux Tel. +31 546 544 811 service.nl@tencategeo.com
Central Eastern Europe Tel. +43 732 6983 0 service.at@tencategeo.com
Czech Republic Tel. +420 2 2425 1843 service.cz@tencategeo.com
France | Africa Fax +33 1 34 23 63 48 service.fr@tencategeo.com
Germany Tel. +49 30 3435 02 10 service.de@tencategeo.com
Italy Tel. +39 0362 34 58 11 service.it@tencategeo.com
Near Middle East Tel. +971 4810 3295 service.nme@tencategeo.com

Poland Tel. +33 1 34 23 53 63 service.pl@tencategeo.com
Russia | CIS Tel. +43 732 6983 0 service.ru@tencategeo.com
Scandinavia | Baltics Tel. +31 546 544 811 geonordic@tencategeo.com
Spain | Portugal Tel. +34 607 489 862 service.es@tencategeo.com
Switzerland Tel. +49 30 3435 02 10 service.ch@tencategeo.com
Turkey Tel. +43 732 5983 0 service.tr@tencategeo.com
UK | Ireland Tel. +44 1952 588 066 service.uk@tencategeo.com



TenCate Geosynthetics Austria Geom.b.H, TenCate Geosynthetics France S.A.S and TenCate Geosynthetics Netherlands b.v. are certified for the design, manufacturing and sales of geotextile and geotextile related products.

Dr.-Ing. Jan Retzlaff
as public appointed and sworn in expert by
the Chamber of Industry and Commerce of Erfurt
for construction textiles and geosynthetics



Client number 725111
Project number 173601

expert's statement

**Verification of the environmental innocuousness
geotextile
TenCate Geolon PP 60**

Ordered on: 04 September 2017

Auftrag von: TenCate Geosynthetics Netherlands B. V.
Hoge Dijkje 2
7442 AE Nijverdal
The Netherlands

Erstellt am: 05 October 2017

Erstellt von: Dr.-Ing. Jan Retzlaff
c/o GEOscope GmbH & Co. KG
Nordstr. 3
99427 Weimar
Germany

Tel.: +49 (0) 3643 251 9857
Email: j.retzlaff@geoscope.eu

This report contains 7 text pages including an enclosure.

General Partner:
GEOscope Verwaltungs GmbH
Nordstr. 3, 99427 Weimar
AG Jena, HRB 510362
Managing Director:
Dr.-Ing. Jan Retzlaff

GEOscope GmbH & Co. KG
AG Jena, HRA 503457
Bank account:
Kreissparkasse Steinfurt
IBAN: DE56 4035 1060 0072 7616 53
SWIFT/BIC: WELADED1STF
VAT-ID: DE265 207 913

Dr.-Ing. Jan Retzlaff
public appointed and sworn in by the Chamber of
Industry and Commerce of Erfurt as an expert
for construction textiles and geosynthetics



attested and approved expert of the Federal Railway
Authority of Germany for geosynthetics (21/16/205)

0 Content

- 1 Order
- 2 Basic information
- 3 Background
- 4 Geosynthetics
- 5 Laboratory testing
- 6 Results
- 7 Evaluation

2 Order

On 2017-09-04 I have been asked by TenCate Geosynthetics Netherlands B. V. to assess the environmental innocuousness of the geotextile TenCate Geolon PP 60

3 Basic information

A product sample and further product information have been provided by the employer. Furthermore up to date standards and references have been used for the development of this statement.

[FGSV-535] FGSV (Hrsg.): Merkblatt über die Anwendung von Geokunststoffen im Erdbau des Straßenbaus. M Geok E. Köln: FGSV, 2016

[DGGT-2005] DGGT (Hrsg.): Empfehlungen zu Dichtungssystemen im Tunnelbau. EAG-EDT Empfehlungen des Arbeitskreises AK 5.1 „Kunststoffe in der Geotechnik und im Wasserbau“ der DGGT. Essen: VGE, 2005

[BBodSchVO-2009] BMJ: Bundes-bodenschutz- und Altlastenverordnung (BBodSchVO). www.juris.de. Stand: 31.07.2009

3 Background

Following general assumptions, polymeric raw materials are not water-soluble and hence do not affect soil or groundwater. There are water-soluble, flushing or edulcorating additives like stabilisers, auxiliary materials or pigments. These substances are in particular the reason of the demand of the verification of environmental innocuousness following M Geok E [FGSV-2005] and EAG-EDT [DGGT-2005]. This verification can be given via ingredients and declaration of environmental innocuousness on the safety data sheet for the corresponding product or via a chemical analysis. Both sources mentioned above are describing a procedure for this purpose. The procedure is referring to methods for the preparation of samples and the analysis mentioned in attachment 1 of BBodSchVO [BBodSchVO-2009]. Unless the test values assessing the effect of soil on groundwater following § 8 para. 1 clause 2 No. 1 under point 3.1 of attachment 2 of [BBodSchVO-2009] are not undercut, the geosynthetic is graded as environmental innocuous if the global parameter TOC in the 5. eluate does not exceed the critical value of 20 mg/l.

According to point 7.6 para. 3 M Geok E the product can still be graded as environmental innocuous, if a small exceedance of the critical values in the fifth eluate is coming along with a significant decrease of the TOC concentration from the first to the fifth eluate.

4 Geosynthetics

Representative tested was a geosynthetics of TenCate Geolon PP 60
This is a geotextile

Samples arrived on 2017-09-07

5 Laboratory testing

The preparation of the samples, the eluates and the chemical analysis of these has been carried out following the analysis mentioned in attachment 1 by a from DAP following DIN EN ISO/IEC 17025:2005 with DAP-PL-3067.00 accredited laboratory for environmental analysis. The laboratory is for the test procedures as listed in enclosure 1 of this report.

6 Results

The critical values shown in the following tables are relevant concerning to the assessment of environmental innocuousness.

Tabelle 1: Results for inorganic substances

Inorganic substances	Critical value [µg/l]	Measurement [µg/l]	Result [-]
antimony	10	< 5	o.k.
arsenic	10	< 5	o.k.
lead	25	< 5	o.k.
cadmium	5	< 0,5	o.k.
chromium, total	50	< 5	o.k.
chromate	8	< 5	o.k.
cobalt	50	< 5	o.k.
copper	50	< 5	o.k.
molybdenum	50	< 5	o.k.
nickel	50	< 5	o.k.
mercury	1	< 0,2	o.k.
selenium	10	< 5	o.k.
zinc	500	11	o.k.
tin	40	< 5	o.k.
cyanide, total	50	< 5	o.k.
cyanide, easily purgeable	10	< 5	o.k.
fluoride	750	< 10	o.k.

Tabelle 2: Results for organic substances

Organic substances	Critical value [µg/l]	Measurement [µg/l]	Result [-]
petroleum derived hydrocarbon	200	< 50	o.k.
arenes	20	< 5	o.k.
benzene	1	< 1	o.k.
volatile halog. hydrocarbon	10	< 8	o.k.
aldrine	0,1	< 0,005	o.k.
DDT	0,1	< 0,03	o.k.
phenole	20	< 10	o.k.
PCB, total	0,05	< 0,03	o.k.
PAH, total	0,2	0,071	o.k.
naphtalene	2	0,21	o.k.

Another criterion is the development of the total TOC from the first eluate to the fifth eluate. The critical value for the total TOC in the fifth eluate is 20 mg/l and shouldn't be exceeded.

Tabelle 3: Results for the development of TOC

Development of TOC	Critical value [µg/l]	Measurement [µg/l]	Result [-]
1 st eluate		2,1	
3 rd eluate		0,44	
5 th eluate	20	0,24	o.k.

The following figure shows the development of the TOC concentration from the first to the fifth eluate:

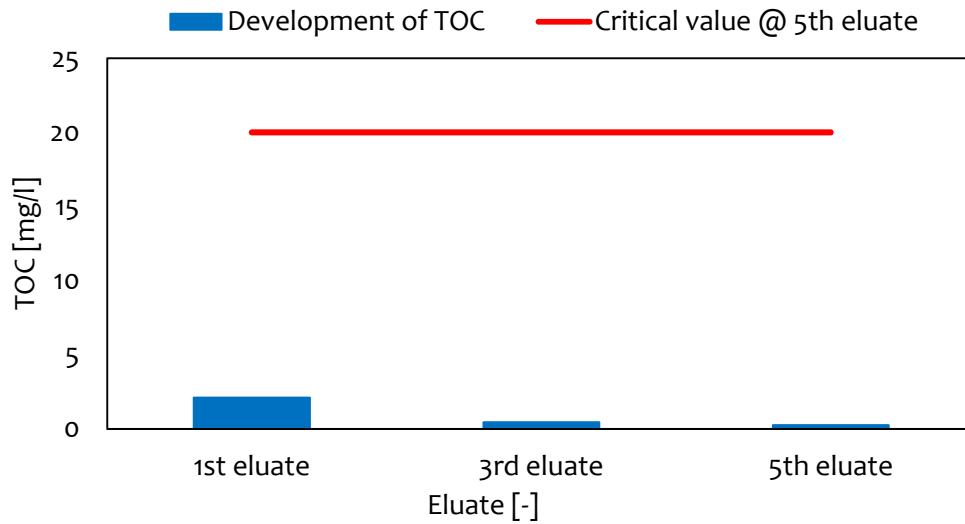

Figure 1: Development of TOC

7 Evaluation

The verification of every single value has shown that the representative tested product can be graded as environmentally innocuous following M Geok E. This evaluation is valid for all members of the product family.

The image shows a handwritten signature in blue ink on the left. To its right is an official blue circular stamp. The stamp contains the text: "Dr.-Ing. Jan Retzlaff", "Bautechnische Textilien und Geokunststoffe", and "Von der Industrie- und Handelskammer öffentlich bestellter und vereidigter Sachverständiger".

Dr.-Ing. Jan Retzlaff

Applied test procedures:

Substances	Detection limit	Standard
antimony	< 5 µg/l	DIN EN ISO 11885
arsenic	< 5 µg/l	DIN EN ISO 11885
lead	< 5 µg/l	DIN EN ISO 11885
cadmium	< 0,5 µg/l	DIN EN ISO 11885
chromium, total	< 5 µg/l	DIN EN ISO 11885
chromate	< 5 µg/l	DIN 38405 - D24
cobalt	< 5 µg/l	DIN EN ISO 11885
copper	< 5 µg/l	DIN EN ISO 11885
molybdenum	< 5 µg/l	DIN EN ISO 11885
nickel	< 5 µg/l	DIN EN ISO 11885
mercury	< 0,2 µg/l	DIN EN 1483 - E12
selenium	< 5 µg/l	DIN EN ISO 11885
zinc	< 5 µg/l	DIN EN ISO 11885
tin	< 5 µg/l	DIN EN ISO 11885
cyanide, total	< 5 µg/l	DIN 38405 - D13
cyanide, easily purgeable	< 5 µg/l	DIN EN ISO 14403 - 1
fluoride	< 10 µg/l	DIN EN ISO 10304 - 1 - D20
petroleum derived hydrocarbon	< 50 µg/l	DIN EN ISO 9377 (GC/FID)
arenes	< 5 µg/l	ISO 11423 - 1
benzene	< 1 µg/l	ISO 11423 - 1
volatile halog. hydrocarbon	< 8 µg/l	DIN EN ISO 10301 - F4
aldrine	< 0,005 µg/l	DIN 38414 - S20
DDT	< 0,03 µg/l	DIN 38414 - S20
phenole	< 10 µg/l	DIN 38409 - H16
PCB, total	< 0,03 µg/l	DIN 38414 - S20
PAH, total	< 0,005 µg/l	DIN ISO 28540
naphtalene	< 0,005 µg/l	DIN ISO 28540
TOC	< 0,1 mg/l	DIN EN 1484 - H3

G.4 Flood gate

May 2020

1 GENERAL

1.1 - The demountable flood barriers are to be a temporary defence system which is erected prior to an expected flooding event and removed afterwards to leave the site in its original state. They shall be simple and quick to install and require a maximum of two people.

1.2 - The system shall generally comprise sectional aluminium beams that fit between fixed end supports and fully removable intermediate posts. Fixings for removable posts to be flush with surrounding surfaces when the system is not erected.

1.3- The demountable system is to be certified to a national standard such as to BS851188-2 or FM Global 2510.

1.4 - The allowable leakage through the demountable defences and their seals shall be in accordance with BS851188-2 which allows for 40litres per metre of seal per hour.

1.5 - The demountable beams are to be lightweight aluminium and each beam is to be a minimum of 300mm high to reduce the number of components required.

1.6 - Where required cast in fixings and baseplates shall be marine grade stainless steel.

1.7 - There shall be no trough or groundbeam allowed on the barrier line that may fill up with debris. The system shall be suitable for concrete surfaces.

1.8 - The design life of the system is to be in excess of 50 years (excluding seals) and the seals are to have a design life of 25 years.

1.9 - The flood barrier system is to have a proven track-record of performance and the flood barrier manufacturer is to have a minimum of five years' experience in supplying flood barriers.

1.10 - All flood barriers shall retain water to the 'flood protection level' as shown on the drawings / as specified. The flood barriers shall be designed to withstand impact loads and wave loads as required

1.11 – Each span shall have a maximum of two clamps to secure the beams in place. The requirement to secure each individual beam will not be permitted.

1.12 - The flood barrier system shall be inherently vandal resistant, utilising vandal resistant fastenings where appropriate. Particular care shall be taken to ensure that seals are protected from vandalism and accidental damage. Seals shall be provided with removable seal covers when barriers are not in place.

1.13 – Seals shall be easily field- replaceable.

2 DESIGN

2.1 – The flood barrier system shall be designed to withstand the water levels and loads as required for the project. These shall include loading from water levels at the full height of the barrier

May 2020

2.2 – The flood barrier system is also to be designed to withstand the given wave impact loads.

2.3 – The flood barrier system is to be designed to remain stable in winds with a peak velocity pressure of 1.14Kn/M²

2.4 – The flood barrier system is to be designed to withstand impact loads of 10Kn acting half way up the structure caused by floating debris.

2.5 – The flood barrier is to be able to withstand an impact load from the dry side of 10.88Kn acting at any point on the barrier.

2.5 – Calculations for a ‘worst case’ loading condition are to be provided with each system to show that beams, posts and fixings operate within their design limits.

3 MATERIALS

3.1 – The demountable barrier system shall utilise heat treated aluminium extruded beams to 6063 T66

3.2 – Aluminium beams are to be able to span 2.5metres minimum at 1.5m high, where geometry allows. This is to reduce the number of components required.

3.3 – Aluminium beams are to be in minimum 300mm increments to reduce the number of individual components required.

3.4 – Maximum aluminium beam weight is to be 25kg, allowing safe handling by one person where required.

3.5 – Steel posts shall be manufactured to EN 10027.

3.6 – Fabrications shall be hot-dip galvanised to ISO 1461:1999.

3.8 – Cast in baseplate shall be manufactured from marine grade stainless steel.

3.9 – Baseplates larger than 0.06m² are to have anti-slip coating applied where in an access area.

3.10 – Exposed/ vertical seals shall be Ethylene Propylene Diene Monomer (EPDM).

3.11 – Where beams are generally to be stored, beam seals are to be manufactured from a highly compressible resilient material.

3.12 – Base seals are to be able to operate on surfaces with a +/- 5mm level tolerance, for where systems are to be erected over existing concrete / impervious surfaces.

3.13 – All fixings to be used are to be load-rated Fixings suitable for the base materials identified on the drawings.

3.14 – The sealant between the end channels and any adjacent structures shall be a fast curing one-component polyurethane sealant/ adhesive with permanent elasticity. Elasticity to be +/- 5% of average joint width at time of sealing.

May 2020

4 PERFORMANCE

4.1 - The allowable leakage through the demountable defences and their seals shall be in accordance with BS851188-2. The specified leakage rate is 40litres/ metre of seal/ hour.

4.2 – The operating temperature shall be at least -20 to +40 degrees Celsius

4.3 – The system shall allow be operable by a minimum of two operatives. The beams for a 2.5m width and 1.5 metre height barrier are to be able to be installed within 3 minutes by two operatives, including removal of any seal covers, and compression of base seals – 1.25m²/minute.

4.4 – The system shall be designed for minimum maintenance. All seals and gaskets shall be field replaceable without specialist tools.

4.5 – Where specified, storage shall be designed to store all components such that seals are not compressed.

4.6 – Sealing shall be mechanical, and not rely solely on hydrostatic pressure. Sealing shall be ‘on-seating’ such that seals are compressed further during flood events when hydrostatic pressure is applied.

4.7 – Cast in items are to be flush with finished surfaces to prevent any trip-hazard when the system is not in use.

5 CERTIFICATION AND TESTING

5.1 – The flood barriers shall be certified to a recognised standard such as BS851188-2 or FM Global 2510. Certificates shall be provided with submittals

5.2 – Selected flood barrier lengths shall be tested to ensure satisfactory performance of the unit and sealing arrangements.

5.2 – Testing shall be carried out on sample sections of barrier – number, but not location, to be specified. Where multi-span barriers are used, the test panel shall include at least one of each component (end channel/ centre post/ beams).

5.3 – Testing is to be undertaken with water retained at full designed flood protection level for a minimum of one hour. The amount of leakage through the barrier is to be quantified, and the leakage rate calculated. The test will be considered to be passed if the leakage is less than compliant with the specification. Should the test fail, then remedial works and further tests shall be undertaken

6 OPERATION AND TRAINING

6.1 - Two sets of tools to operate and maintain the barriers shall be supplied with the system.

6.2 – Two copies of an Operations and Maintenance Manual shall be supplied, including installation instructions, a full component list and a user-guide.

May 2020

6.3 – A video sequence shall be provided to show installation/ removal of barrier components for future training.

6.4 - Components shall be identified using clear and durable labelling on each component, identifying its installed location. A plan of installation locations shall be provided at storage locations to assist in speedy erection.

INSTALLATION INSTRUCTIONS



Multi Span Demountable Flood Barriers

Flood Control International Limited

Kilworthy Park • Tavistock • Devon • PL19 0FZ • UK

tel: +44 (0)1822 619730 • enquiries@floodcontrolint.com • www.floodcontrolinternational.com

CONTENTS

1. INTRODUCTION -----	3
2. TOOLS AND MATERIALS REQUIRED-----	3
3. TYPES OF BARRIER MOUNT-----	3
3.1 Recess Mount-----	3
3.2 Surface Mount -----	4
4. PREPARATION-----	4
5. INSTALLATION-----	5
6. AFTER INSTALLATION -----	10
7. ADDITIONAL WORKS FOR SECURITY COVERS -----	10

Before installing equipment, please read the following instructions carefully.

They contain important information for the installation and operation of the equipment. Keep these instructions in a safe place.

Flood Control International Limited reserves the right to alter product specifications without notice.

INSTALLATION OF MULTI SPAN DEMOUNTABLE FLOOD BARRIERS

1. INTRODUCTION

These Installation Instructions are intended for Flood Control International's multi span demountable flood barriers. The demountable flood barrier system comprises interlocking aluminium 'dam boards' which slot into steel end channels and intermediate support posts to create a watertight barrier across openings. In operation, the dam boards are clamped into position using galvanised steel clamps to compress the base seal and to secure the system. The system is able to be padlocked with special padlockable clamps if required.

Although the components of the system are not heavy, it is recommended that two people install the barrier system.

2. TOOLS AND MATERIALS REQUIRED

- Masonry drill (SDS) with 10mm drill bit
- Impact Driver with TX50 bit for countersunk fixings and 15mm hex socket for bolt head fixings
- 6mm allen key if handles are required for the aluminium beams
- Air blower or vacuum to remove dust from holes
- Spirit level
- Fixings and tools as listed in component list shipped with barrier, including 8mm allen key, 24mm spanner
- Sikaflex-11FC waterproof sealant and sealant gun.

3. TYPES OF BARRIER MOUNT

Demountable flood barriers can be mounted against wall openings in two ways; recess mount or surface mount. The type of mount affects the installation. Ensure you identify the correct procedure for the type of barrier mount to be installed. Generally, recess mount fixings are countersunk, surface mount fixings are bolt head.

3.1 Recess Mount

Recess mount is when the end channels are parallel to the wall as is illustrated in Figure 1.

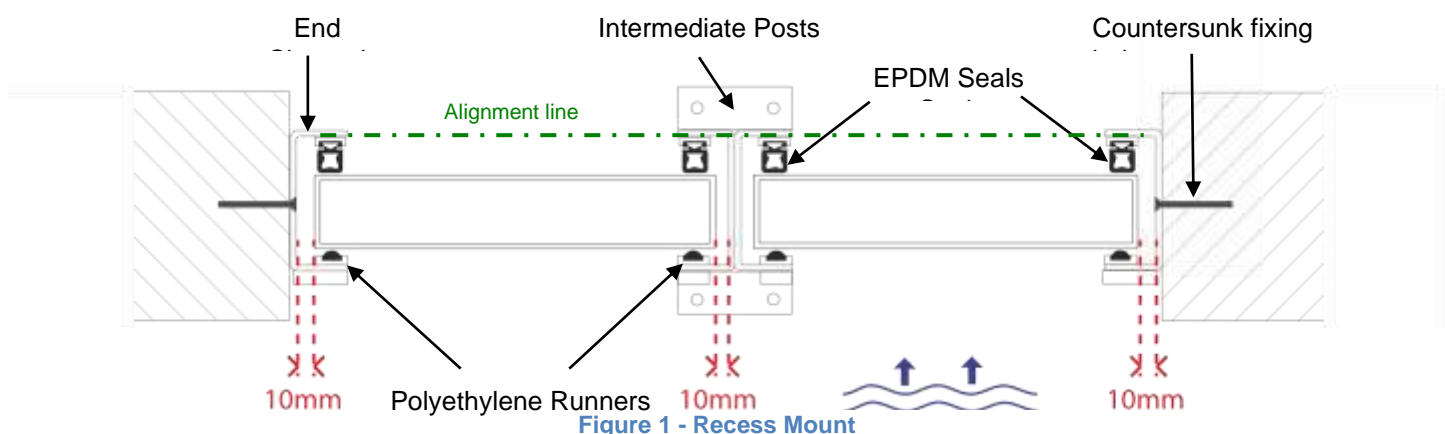

3.2 Surface Mount

Surface mount is when the end channels are perpendicular to the wall as is illustrated in Figure

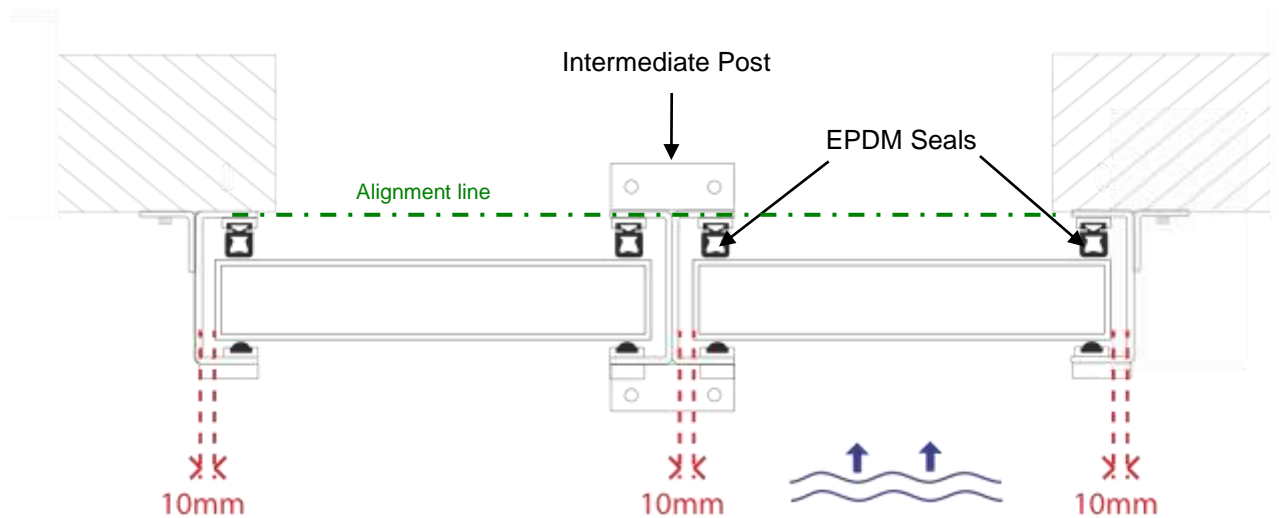

2.

Figure 2 - Surface Mount

Please note that the surface mount configuration can be designed so that the barrier sits on the 'dry' side of the wall. Please check the individual drawings for correct location.

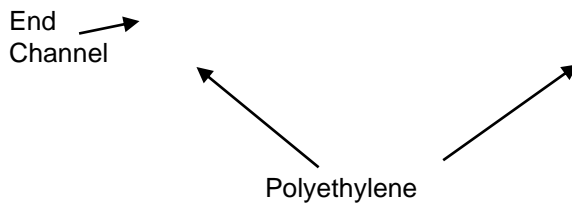

4. PREPARATION

- 4.1 Set out and check all components and fixings according to the components list shipped with the barrier before beginning installation and check which mount configuration is applicable for the barrier.
- 4.2 Check the dimensions of the opening are in accordance with the flood barrier drawings.
- 4.3 Loose or flaking areas must be cleaned back to sound material and made good.
- 4.4 The ground surface must be smooth, level and impervious to water.
- 4.5 All surfaces must be free from dirt and grease.
- 4.6 Intermediate post components (supports, braces, compression bars) require the installation of ground anchors. These anchors are usually chemically fixed anchor sleeves and bolts must be installed in accordance with the CAD drawings shipped with the barrier system.

NB Do not attempt to apply the Sikaflex-11FC in temperatures below 5°C or above 40°C.

5. INSTALLATION

The handles for the aluminium beams may have been packed separately to assist with shipping. The beams have threaded inserts already in place – simply screw the handles to the beams using the small bolts provided and seal with a dab of Sikaflex-11FC.

- 5.1 Offer up an end channel, ensuring that it is vertical and at right angles to the ground surface (Figure 3). All fixing points provided on your system **MUST** be utilised. Systems that are higher than 1200mm may have extra fixing points.

NB For recess end channels with optional security cover plates, see Section 7 before installation.

- 5.2 Use a good quality masonry bit to drill out the hole for the top fixing, ensuring that the hole is dust free. It is imperative that the drilling depth is sufficient to allow the bolt or screw to be fully tightened. For specialised fixings, the manufacturer's instructions **MUST** be followed.

- 5.3 Position the end channel to the wall, rechecking alignment. Loosely insert a fixing bolt through the end channel into the top hole. Drill through the remaining fixing holes to ensure that they all align correctly.

- 5.4 Fix the end channel to the wall, rechecking alignment.

- 5.5 Use a string line or equivalent to set out the alignment of each intermediate support and the second end channel so that they are precisely aligned - see green alignment line. (Figures 1, 2 and 4)

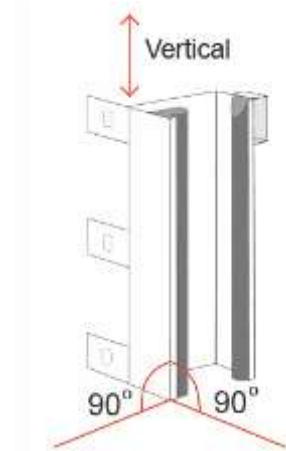

Figure 3

Alignment line

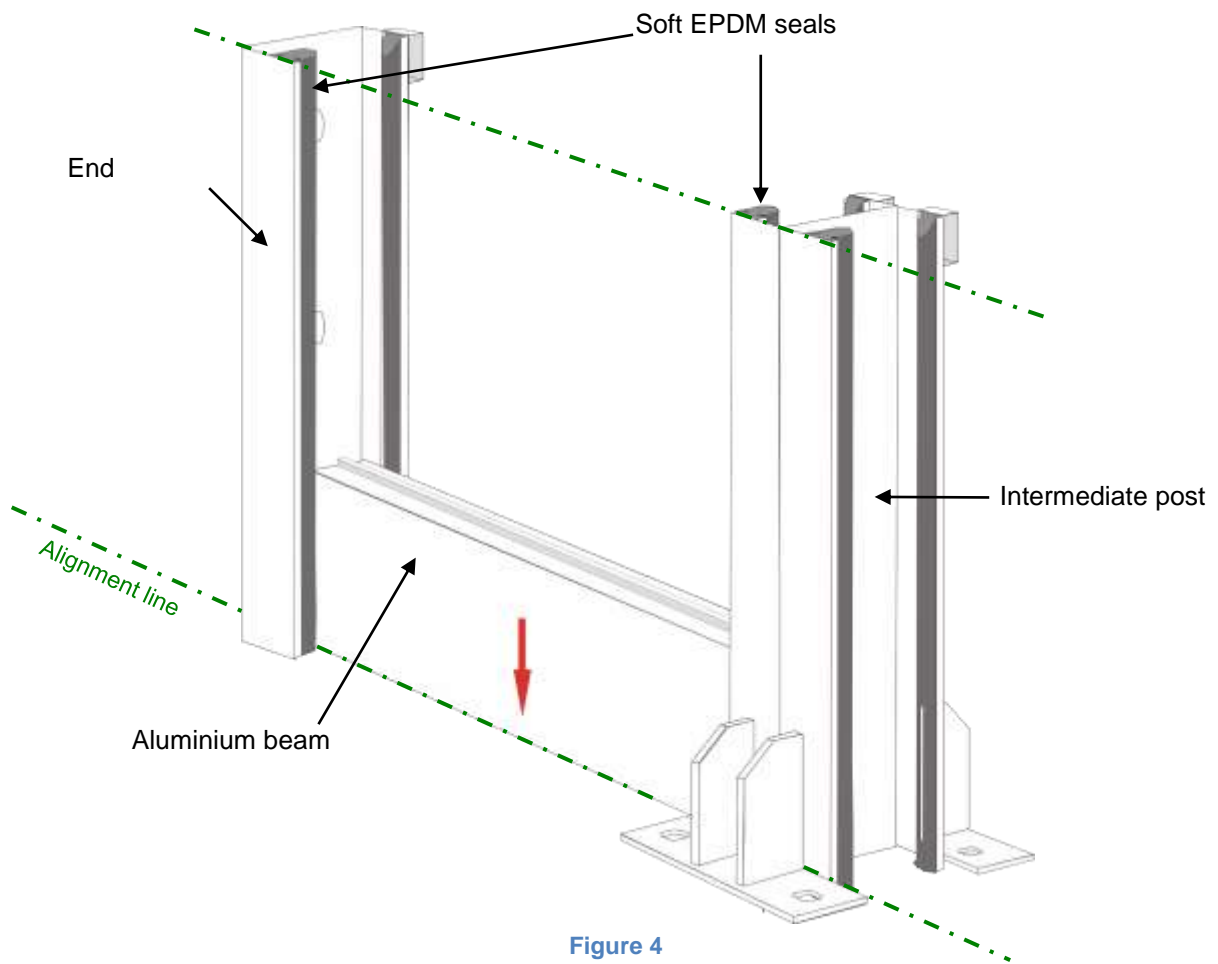

Figure 4

5.5 Insert an aluminium beam into the end channel and intermediate support as a guide. Ensure that there is 5mm - 10mm clearance between the end of the beam and the inner wall of the channel. (Figure 5)

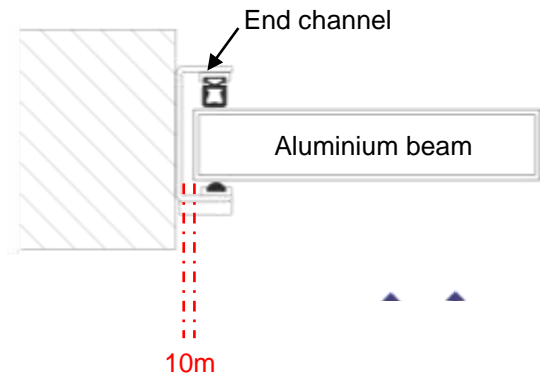

Figure 5

5.6 Ensure that the intermediate supports are correctly spaced apart. Use aluminium beams as guides as necessary, leave a gap of 5mm - 10mm between the end of the beam and the inner wall of each support channel. (Figure 6)

5.7 Position the second end channel using an aluminium beam as a guide, making sure that it is vertical and at 90° to the ground surface (Figure 3). This should leave a 5mm - 10mm gap between the end of the beam and the inner wall of the end channel. The end channels should be aligned. (See Figures 1 & 2)

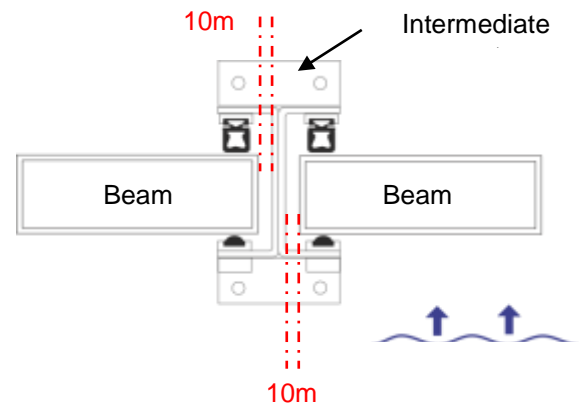

Figure 6

5.8 Use a good quality masonry bit, drill out the holes as described in Section 5.2 and 5.3.

5.9 Fix the end channel to the wall, rechecking alignment.

5.10 Remove aluminium beams from between the channels.

5.11 Ensure the intermediate supports are vertical before marking out and carefully drilling pilot holes for the final fixing anchor bolts through the fixing holes. Depending on the system, a drilling template may be supplied.

5.12 Remove the intermediate support and use a good quality masonry bit to drill out the holes in the ground (Figure 7). Follow the manufacturer's instructions for drilling dimensions. It is imperative that the drilling depth is sufficient to allow bolts to be fully tightened.

5.13 If the intermediate support post anchor bolts go through paving, the hole diameter will change in accordance with whether an anchor socket is required. The drilling template provides a drill bit centre guide to allow precise location of the deeper, smaller diameter holes in the reinforcement.

5.14 Clean out the holes using an air blower or vacuum.

5.15 Insert epoxy and socket into each hole using the tools detailed in the manufacturer's instructions. Ensure that all of the fixings fit correctly by loosely bolting the post in place before the epoxy sets.

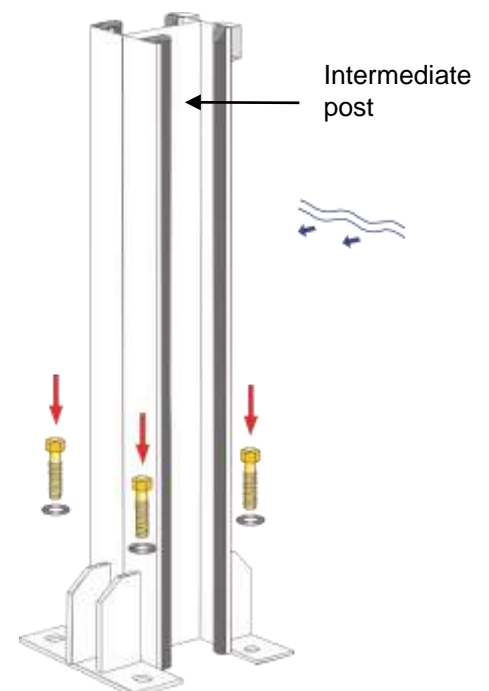

5.16 When the epoxy has hardened, fix the intermediate posts to the ground using the washers and anchor bolts provided. (Figure 7)

Figure 7

5.17 Apply a 5-10mm bead of Sikaflex-11FC to the back of the end channels before final tightening, as shown in Figure 8. The sikaflex should also run along the base of the channel to the underside of the soft EPDM seal.

5.18 Adjust fixing screws to final tightness.

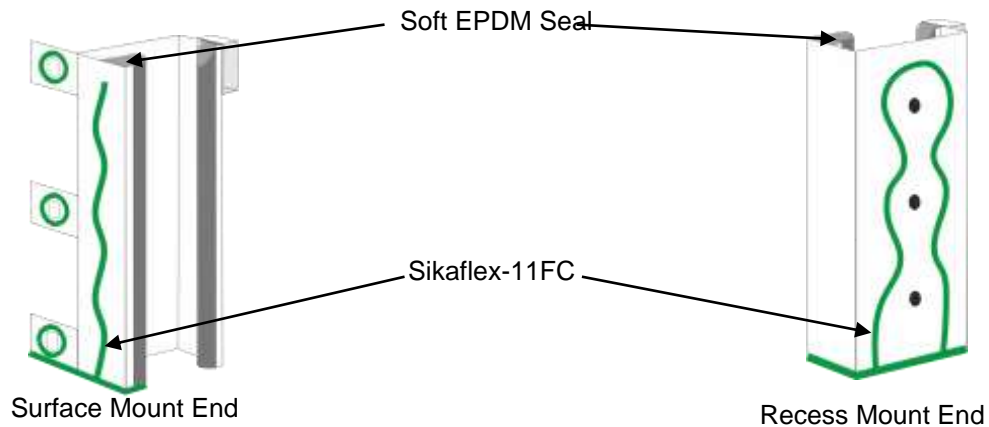

Figure 8

5.19 Now use Sikaflex-11FC sealant to create an additional watertight seal around the edges of the end channels; apply it to:

- All gaps between the end channels and the walls
- The base of the channels where they meet the ground surface
- ANY gaps between the EPDM vertical channel seals and the ground.

NB Sikaflex-11FC must not be applied in temperatures below 5°C or above 40°C.

5.20 Use sufficient sealant to ensure a watertight seal. Figure 6 illustrates where to Sikaflex the surface mount end channels. Figure 7 illustrates where to Sikaflex the recess mount end channels.

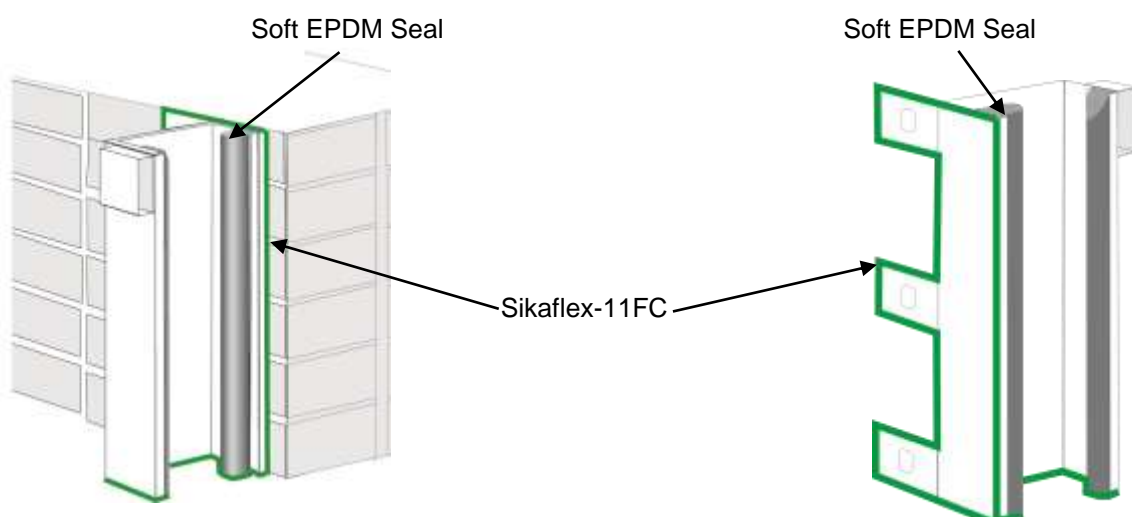

Figure 9 - Sikaflex for Surface Mount End Channels

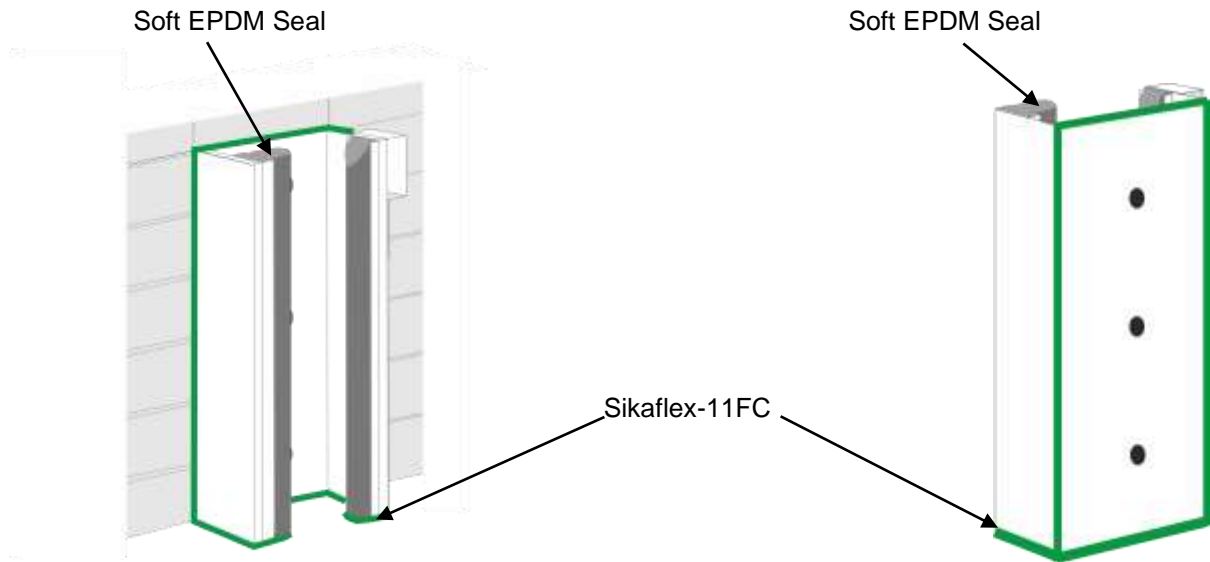

Figure 10 - Sikaflex for Recess Mount End Channels

- 5.21 For flood barriers over 1.8m high, treating channel seals with a fine application of silicone spray will allow the beams to slide easily into position. (Silicone spray ONLY.)

6. AFTER INSTALLATION

Allow the sikaflex to dry for 24 hours before operational use. This ensures that the soft base seal does not adhere to the sikaflex when installed, and ripping when the bottom beam is removed.

Operating and Maintenance Instructions are supplied in a separate document, shipped with the barrier.

7. ADDITIONAL WORKS FOR SECURITY COVERS

If the flood barrier you are installing has optional security covers, the recess mounted end channels have domed nuts welded onto the back of the channel to allow fixing of the cover plates. To accommodate these domed nuts, a short clearance hole needs to be drilled into the wall for when the end channel is positioned flush against the wall.

- 7.1 Position the end channels as normal.
- 7.2 Mark the location where the domed nuts meet the wall.
- 7.3 Drill a 15mm (minimum) hole 20mm deep into the wall at the domed nut locations.
- 7.4 Reposition the end channels as before and then drill for the fixing holes.



Flood Control International Limited

Kilworthy Park • Tavistock • Devon • PL19 0FZ • UK

tel: +44 (0)1822 619730 • enquiries@floodcontrolint.com • www.floodcontrolinternational.com

OPERATION & MAINTENANCE INSTRUCTIONS

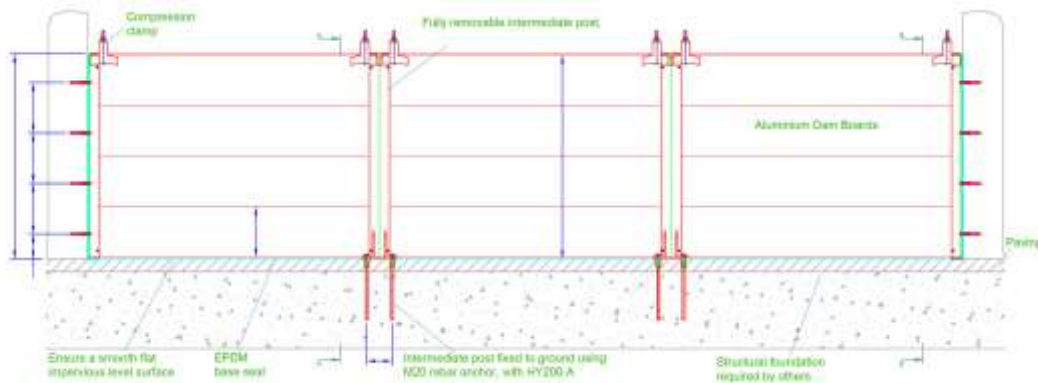

Fully Removable Multi-Span Slot-In Flood Barriers

Flood Control International Limited
Kilworthy Park • Tavistock • Devon • PL19 0FZ • UK
tel: +44 (0)1822 619730 • enquiries@floodcontrolint.com • www.floodcontrolinternational.com

CONTENTS

1.	TOOLS REQUIRED -----	3
2.	OVERVIEW -----	3
3.	COMPONENTS -----	3
3.1	Removable End Supports-----	4
3.2	Dam Boards -----	4
3.3	Intermediate Support Posts-----	4
3.4	Compression Clamps -----	4
4.	INSTALLING THE REMOVABLE END SUPPORTS -----	5
5.	INSTALLING INTERMEDIATE POSTS -----	5
6.	INSTALLING ALUMINIUM DAM BOARDS -----	5
8.	REMOVING ALUMINIUM DAM BOARDS AFTER USE -----	6
9.	REMOVING INTERMEDIATE SUPPORT POSTS -----	6
10.	MAINTENANCE GUIDELINES -----	6
11.	SUGGESTED SPARES -----	7

Before operating the equipment, please read the following instructions carefully.

They contain important information for use and maintenance of the equipment. Keep these instructions in a safe place for maintenance purposes or for ordering spare parts.

Flood Control International Limited reserves the right to alter product specifications without notice.

OPERATING & MAINTENANCE INSTRUCTIONS FOR FULLY REMOVABLE MULTI-SPAN SLOT-IN FLOOD BARRIERS

1. TOOLS REQUIRED

- Allen Key No 8 to tighten or loosen the compression clamps.
- 24mm spanner for clamps
- 17mm spanner for M10 bolts
- 30mm spanner to tighten the M20 bolts to install and remove the intermediate posts.
- a wide flat screwdriver to remove the blanking bolts.

2. OVERVIEW

These Operation and Maintenance Instructions are intended for Flood Control International's Fully Removable Slot-In Flood Barriers.

The barriers have their own unique drawing giving the dimensions and any special details. These drawings will be in the handover documentation that accompanies this Operation and Maintenance Manual.

The flood barrier system comprises interlocking aluminium 'dam boards' which slot into fully removable steel end support channels and removable intermediate support posts to create a watertight barrier across openings. Once the dam boards are positioned, they are clamped into position using galvanised steel clamps to compress the base seal and to secure the system.

The seals have excellent resistance to UV, weathering and floodwater. Tests have shown water tightness with a leakage rate of 6-10 litres per metre per hour. The flood barriers are manufactured to BS EN1090.

An overview of the barriers is shown in Figure 1.

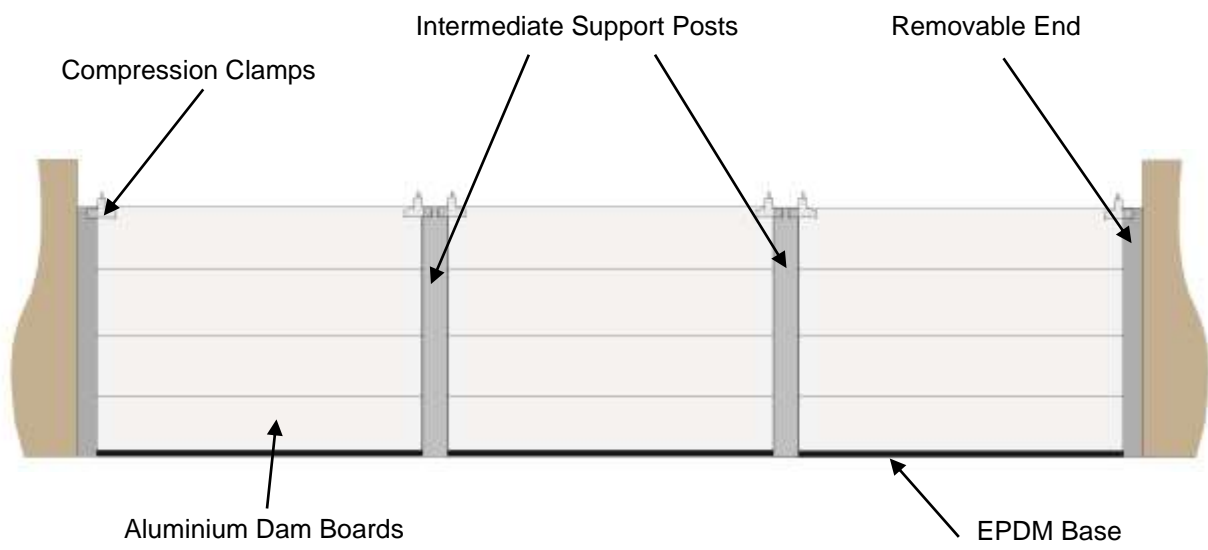

Figure 1 - Elevation

3. COMPONENTS

3.1 Removable End Supports

These are galvanised steel channels with vertical seals and polyurethane running strips. At the top of the end supports there is a 'clamp box' welded to the side of the channel for the compression clamp to fit into. (Figure 2) The back of the end channels are fitted with seals so that when installed correctly, a watertight seal is achieved.

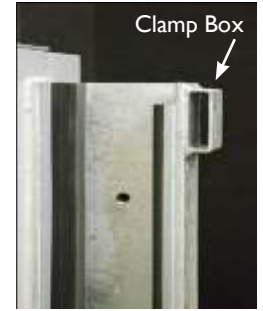

Figure 2

3.2 Dam Boards

Aluminium dam boards are 300mm high, 57mm wide, with lengths to suit the opening. The dam boards interlock, and the bottom dam board has a squashy seal at its base.

3.3 Intermediate Support Posts

Galvanised steel intermediate support posts are used to support the ends of the dam boards. The posts are fixed into cast-in sockets using four M20 bolts each. The posts have a vertical EPDM rubber seal and a vertical polyurethane 'runner' either side (Figure 3). At the top of posts there are 'clamp boxes' welded to the sides of the post for the compression clamps to fit into. When not fitted, the cast-in sockets are protected against dirt etc by blanking bolts. (Figure 4)



Figure 3



Figure 4

3.4 Compression Clamps

Galvanised steel compression clamps (Figure 5) comprise a short box section fixed to the clamp bolt, which is threaded through the main plate of the clamp.

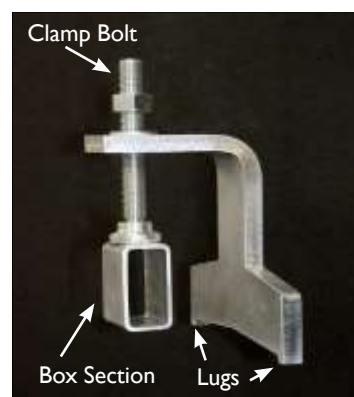

Figure 5

4. INSTALLING THE REMOVABLE END SUPPORTS

- 4.1 Remove and retain the M10 domed blanking bolts from the wall where the end channel is to be positioned.
- 4.2 Offer up an end support into its position, ensuring that it is vertical and at right angles to the ground surface.
- 4.3 Once positioned, use the M10 countersunk bolts to fix the channel to the pre-installed Hilti HIS-RN socket anchors in the wall (as detailed in the component list and drawings). Ensure that the fixing bolts are tightened so that the seal on the back of the channel is sufficiently compressed to form a watertight seal.
- 4.4 Repeat for the other end support.

5. INSTALLING INTERMEDIATE POSTS

- 5.1 Using a wide flat screwdriver, remove the four M20 domed blanking bolts from the post sockets and retain. (Figure 4)
- 5.2 Position the intermediate support post over the sockets. The rubber seal MUST be on the same side as the rubber seals in the end channels ie if the rubber seals are on the 'wet side' of the barrier at the end channels, then the rubber seals on the post need to be on the 'wet side' of the post, when positioned.
- 5.3 Bolt the intermediate support post to the floor using the M20 rebar anchors with HY-200A bolts and tighten.
- 5.4 Repeat for all intermediate support posts in the system.

6. INSTALLING ALUMINIUM DAM BOARDS

- 6.1 The first dam board to be installed has a large squashy seal at the bottom (Figure 6). Position the dam board into the slots of the steel end supports / intermediate posts and push vertically downwards until it reaches the floor.
- 6.2 Install subsequent beams in a similar manner so that they interlock. (Beams the correct way up have the small horizontal seals at the top).
- 6.3 When all beams are installed, fit the compression clamps to either end. This is done by lowering the box-section at the end of the clamp bolt into the groove at the top of the aluminium dam board, with the main body of the clamp hanging down on the same side as the clamp box which is welded on the end support / intermediate post. (Figure 7)



Figure 6



Figure 7



Figure 8



Figure 9

- 6.4 The compression clamp is now slid sideways so that the end of the clamp slides into the clamp box, and the 'lug' on the end of the compression clamp clears the far side of the clamp box.
- 6.5 Tighten the compression clamp by using the No 8 allen key and turning the clamp bolt until the box section on the end of the threaded clamp bolt is pushing the aluminium beams down. (Figure 8)
- 6.6 Repeat the clamping to both sides for each span.
- 6.7 Fully tighten the clamp bolts with the allen key provided so that the bottom seal is compressed along its entire length evenly.
- 6.8 To 'lock off' the clamps, now tighten the clamp nut with the 24mm spanner (Figure 9).

8. REMOVING ALUMINIUM DAM BOARDS AFTER USE

- 8.1 Unlock the compression clamp using the 24mm spanner on the nut. Loosen off the clamp bolt using the No 8 allen key that fits into the top of the bolt.
- 8.2 Once the compression clamps for each span have been loosened, slide out and remove the clamps from the end channels / intermediate posts.
- 8.3 Remove the aluminium dam boards one at a time by lifting them out of the channels. Ensure that the dam boards are placed upside down in storage so that the bottom dam board is stored with the squashy seal uppermost.

9. REMOVING INTERMEDIATE SUPPORT POSTS

- 9.1 Remove the M20 bolts that fix the bases of the intermediate posts using a 30mm spanner.
- 9.2 Using a wide flat screwdriver, place the four blanking bolts into the holes left by the M20 bolts.
- 9.3 Remove all equipment to its dedicated storage.

10. MAINTENANCE GUIDELINES

- 10.1 After experiencing a flood event it is recommended that all seals are rinsed down with a very mild disinfectant and hosed with fresh water as floodwaters can often carry contaminants.
- 10.2 Under normal circumstances the barriers do not need any maintenance. A general inspection

should be undertaken annually.

- 10.3 *Seals* - an inspection of the vertical seals, main horizontal seal and small horizontal beam seals should be undertaken annually. Where seals have been damaged, these should be replaced.
- 10.4 *Clamping Mechanism* - the threaded rod element of the clamp should be tested for ease of use. A general lubricant may assist in the easy operation of the threaded bar.
- 10.5 *Intermediate Post locations* - the stainless steel grub screws located within the cast-in sockets should be cleaned, checked and tested for operation.

11. SUGGESTED SPARES

Spares should include seals for where any mechanical damage has occurred to existing seals:

- 11.1 Vertical EPDM seal to end channels – 10 linear metres

Expected Operational Life:	15 years
Suggested Replacement Time:	10 years

- 11.2 Horizontal small seal between aluminium beams – 10 linear metres

Expected Operational Life:	15 years
Suggested Replacement Time:	10 years

- 11.3 Horizontal large seal to base of bottom barrier beam – 4*2.5m lengths

Expected Operational Life:	15 years (stored) 5 years (permanently installed)
Suggested Replacement Time:	10 years (generally stored) 3 years (permanently installed)



Flood Control International Limited

Kilworthy Park • Tavistock • Devon • PL19 0FZ • UK
tel: +44 (0)1822 619730 • enquiries@floodcontrolint.com • www.floodcontrolinternational.com



HR Wallingford
Working with water



DMR 719286



FS 516431



OHS 595357



EMS 558310

© HR Wallingford Ltd

HR Wallingford is an independent engineering and environmental hydraulics organisation. We deliver practical solutions to the complex water-related challenges faced by our international clients. A dynamic research programme underpins all that we do and keeps us at the leading edge. Our unique mix of know-how, assets and facilities includes state of the art physical modelling laboratories, a full range of numerical modelling tools and, above all, enthusiastic people with world-renowned skills and expertise.

HR Wallingford Ltd, Howbery Park, Wallingford, Oxfordshire OX10 8BA, United Kingdom
tel +44 (0)1491 835381, email info@hrwallingford.com
www.hrwallingford.com